

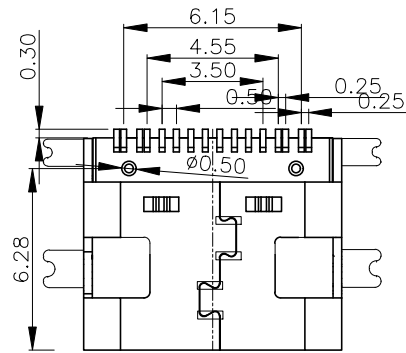

REV.	ECN NO OR DESCRIPTION	REVISED	DATE

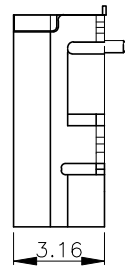
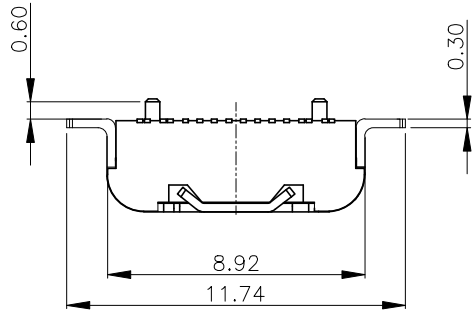

NOTE:

- 1.MATERIAL SPECIFICATION:
 - 1.HOUSING:HIGH TEMPERATURE RESISTANT PLASTIC,UL94 V-0.
 - 2.CONTACTS:COPPER ALLOY
 - 3.MID PLATE: STAINLESS STEEL
 - 4.FRONT SHELL: STAINLESS STEEL
- 2.PLATING SPECIFICATION:
 - 2-1.CONTACTS:
 - Ni 50u" MIN. UNDER PLATED OVER ALL.
 - Au PLATED ON THE FUNCTIONAL AREA OF CONTACT.
 - (GOLD PLATING THICKNESS FOLLOW THE P/N)
 - PLATING SPECIFICATIONS OF THE SOLDER AREA FOLLOW THE P/N
 - 2-2.FRONT SHELL:
 - SEE TABLE1.
 - 2-3.SHIELD PLATE&EMI PLATE:
 - CLEAR ONLY
- 3.MECHANICAL PERFORMANCE,
 - 3-1.INSERTION FORCE: 0.5~2.0kgf.
 - 3-2.REMOVAL FORCE: 0.8kgf~2.0kgf.
 - 3-3.DURABILITY: 10000 CYCLES.
- 4.ELECTRICAL PERFORMANCE,
 - 4-1. CURRENT RATING:3.0A
VOLTAGE RATING:5.0V
 - 4-2. LLCR:
 - VBUS & GND PINS AND OTHER PINS: 40ma/PIN MAX.
 - SHIELD: 50ma/MAX.
 - LLCR MAX. CHANGE OF ALL PINS: 10ma.
 - 4-3.INSULATION RESISTANCE: 100MΩ MIN
 - 4-4.DIELECTRIC WITHSTAND VOLTAGE,AC 100V FOR 1 MINUTE.
5. ENVIRONMENTAL PERFORMANCE:
 - OPERATING TEMPERATURE: -25°C~+85°C.
- 6.IR REFLOW:
 - THE PEAK TEMPERATURE ON THE BOARD SHALL BE MAINTAINED FOR 10 SECONDS AT 260°C.

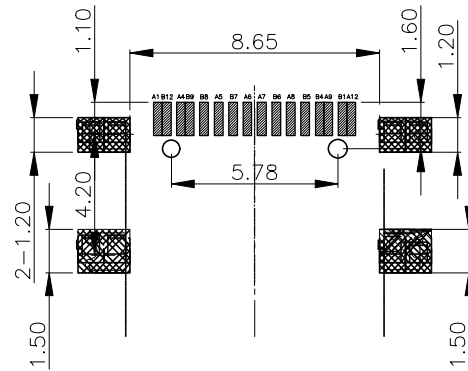
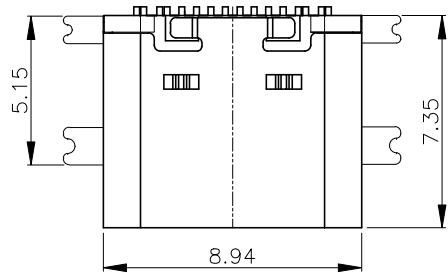

PCB LAYOUT(Recommend)
(General Tolerance:±0.05)

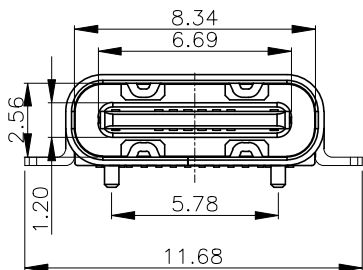

UNLESS OTHERWISE SPECIFIED TOLERANCES		东莞市汉博电子科技有限公司 DONGGUAN HANBO TECHNOLOGY CO., LTD			
DECIMALS:	ANGLES:	TITLE	TYPE-C 16Pin 板上四脚全贴 7.35mm		
X. :±0.20	X° :±2°	DWN	xiong	MC-107S	
X.X :±0.15	X.X° :±1°	CHKD	lee	SCALE:1:1	UNIT: mm
X.XX :±0.10		APVD	wang	SIZE: A4	SHEET:10F 1
		REV: A4			
CUSTOMER COPY					