

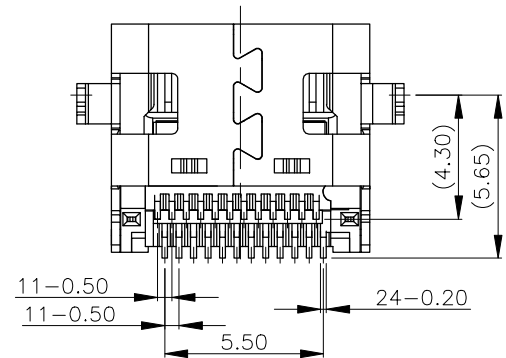

REV.	ECN NO OR DESCRIPTION	REVISED	DATE

NOTES:
 1.MECHANICAL PERFORMANCE,
 1-1.INSERTION FORCE: 5N~20N.
 1-2.REMOVAL FORCE: 5N~20N.
 1-3.DURABILITY: 10000 CYCLES.
 2.ELECTRICAL PERFORMANCE,
 2-1. CURRENT RATING: 5.0A
 VOLTAGE RATING: 5.0V
 2-2. LLCR: VBUS & GND PINS AND OTHER PINS: 40mΩ/PIN MAX.SHIELD: 50mΩ/MAX.
 2-3.INSULATION RESISTANCE: 100MΩ MIN
 2-4.DIELECTRIC WITHSTAND VOLTAGE,AC 100V FOR 1 MINUTE.
 3.ENVIRONMENTAL PERFORMANCE:
 OPERATING TEMPERATURE: -25°C~+85°C.

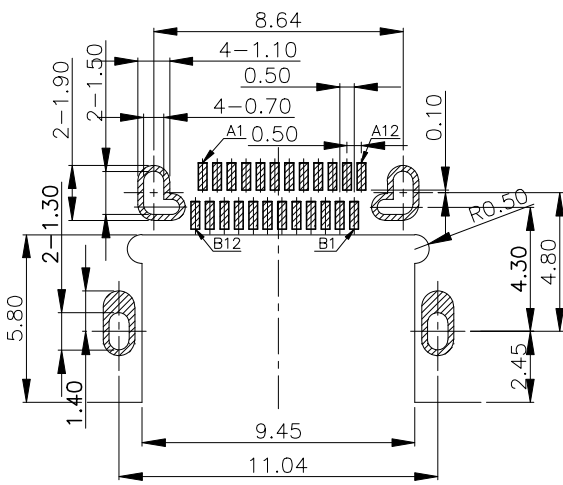
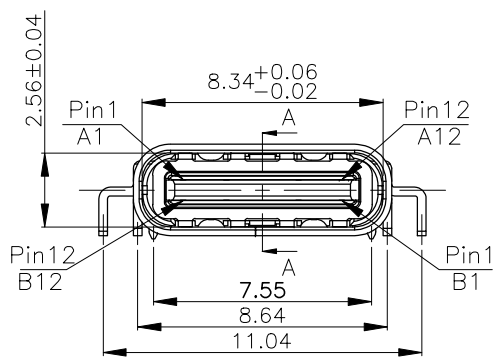
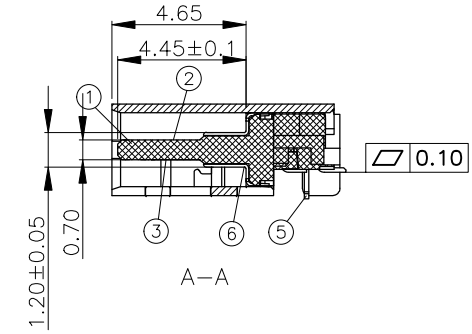
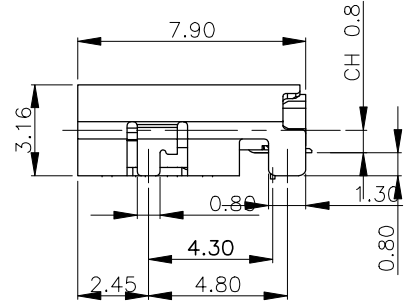
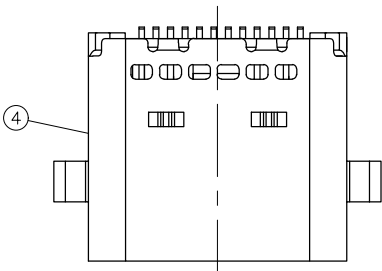
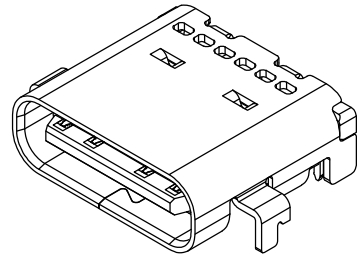

PIN ASSIGNMENTS:

PIN No.	A1	A2	A3	A4	A5	A6	A7	A8	A9	A10	A11	A12
SIGNAL NAME	GND	TX1+ TX1-	Vbus	CC1	D+	D-	SBU1	Vbus	RX2-	RX2+	GND	
PIN No.	B12	B11	B10	B9	B8	B7	B6	B5	B4	B3	B2	B1
SIGNAL NAME	GND	RX1+	RX1-	Vbus	SUB2	D-	D+	CC2	Vbus	TX2-	TX2+	GND

⑥	EMI PLATE	1 PCS	STAINLESS STEEL T=0.10	
⑥	MID PLATE	1 PCS	STAINLESS STEEL T=0.15	Soldering Plating: Sn
④	SHELL	1 PCS	STAINLESS STEEL T=0.3	Ni
③	TERMINAL 2(12Pin)	1SET	COPPER ALLOY T=0.15	Under Plating: Ni Contact Plating: Au
②	TERMINAL 1(12Pin)	1SET	COPPER ALLOY T=0.15	Soldering Plating: Au
①	HOUSING	1 PCS	HIGH TEMP.THERMOPLASTIC UL94V-0	BLACK
NO.	PART NAME	QTY.	MATERIAL	REMARK

UNLESS OTHERWISE SPECIFIED TOLERANCES

DECIMALS: X. :±0.20 X.X :±0.15 X.XX :±0.10
 ANGLES: X° :±2° X.X° :±1°

TITLE: USB Type C 24P 及 规格书 CH0.8 SMT 厚度 L=7.9(EMI 拉特款)
 DWN xiong MC-210
 CHKD lee SCALE:1:1 UNIT: mm
 APVD wang SIZE: A4 SHEET:10F 1 REV: A4

CUSTOMER COPY

东莞市汉博电子科技有限公司
 DONGGUAN HANBO TECHNOLOGY CO., LTD

RECOMMENDED P.C.B. LAYOUT
 TOLERANCE UNSPECIFIED ±0.05mm