

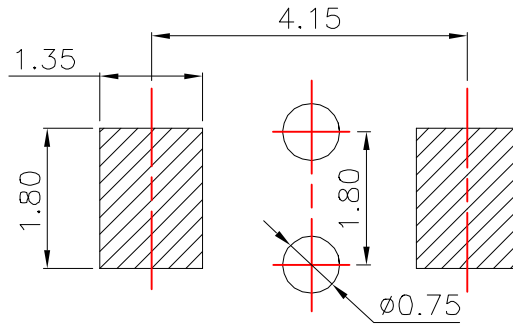

REV.	ECN NO OR DESCRIPTION	REVISED	DATE

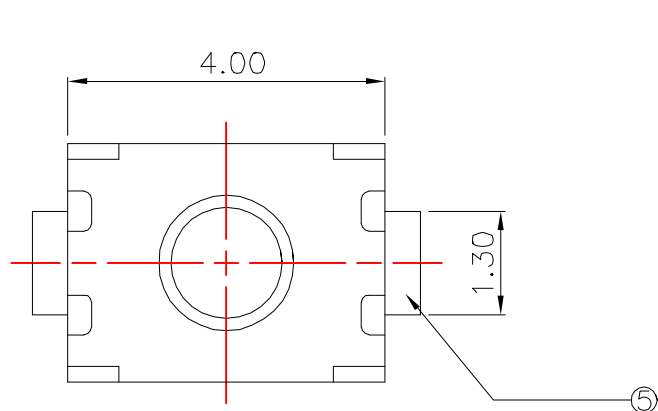

PCB Layout

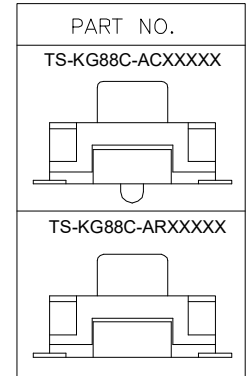

product height	
Code	H
20	2.0
25	2.5

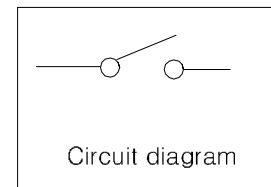

Circuit diagram

P/N: TS-KG088C-X X XX X

A-不锈钢
B-覆磷铜
C-带柱
R-不带柱
T-编带
B-散装

G-150±50gf
F-250±50gf
H-高度

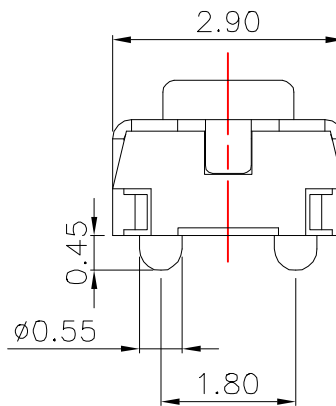
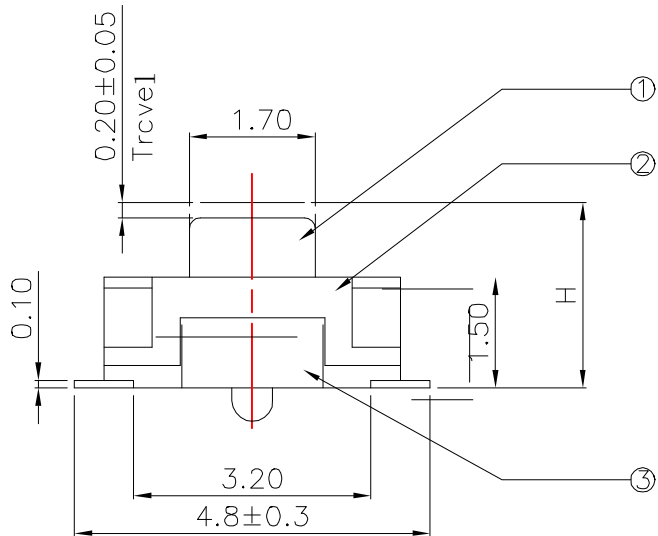

ITEM	PART NAME	TER'NO.	QTY.	MATERIAL	FINISHING	REMARK
⑥	Dust cover	—	1	KAPTON FILM	—	—
⑤	Terminal	—	2	Brass(0.30t)	Plating silver	—
④	Contact	—	2	F.Ag/SUS	—	—
③	Base	—	1	Nylon	Black	—
②	Cover	—	1	SUS	Plating Nickel	—
①	Keystoke	—	1	Nylon	Black	—

UNLESS OTHERWISE SPECIFIED TOLERANCES

DECIMALS: 30~以上±0.30
10~30±0.20
5~10±0.15
~5±0.10

ANGLES: :±2°

东莞市汉博电子科技有限公司
DONGGUAN HANBO TECHNOLOGY CO., LTD

TITLE		TACT SWITCH		
DWN	xiong	PART NO. TS-KG88C-XXXXXX		
CHKD	lee	SCALE:1:1	UNIT: mm	
APVD	wang	SIZE: A4	SHEET:10F 1	REV: A4

CUSTOMER COPY