

规格书

SPECIFICATION

产品名称 石英晶体谐振器

Description Crystal Unit

型号 · 标称频率

Type · Nominal Frequency 49S-SMD 27.120MHz

规格书号

Specification . JFWSJ27A20A204C

制作

DESIGNED BY 杨 阳

审核

CHECKED BY 何 珍

批准

APPROBED BY 肖 琳

技术特性 Specification

1	标称频率 Nominal Frequency	27.120MHz
2	规格型号 Holder Type	HC-49SMD
3	振动模式 Mode of Oscillation	Fund AT
4	调整频差 Frequency Tolerance at (25°C ±2°C)	±20ppm
5	温度频差 Temperature Frequency Stability vs Temp	±20ppm
6	工作温度 Operating Temperature Range	-20~+70°C
7	贮存温度 Storage Temperature Range	-45~+80°C
8	负载电容 Load Capacitance	20pF
9	静电容 Shunt capacitance	<5PF (Max)
10	等效电阻 Equivalent Series Resistance	<30 Ω (Max)
11	激励功率 Drive Level	50 u W
12	绝缘阻抗 Insulation Resistance	500M Ω at DC100V
13	年老化率 Aging Rate a Year	±5PPM

尺寸构造 Dimensions & Structure

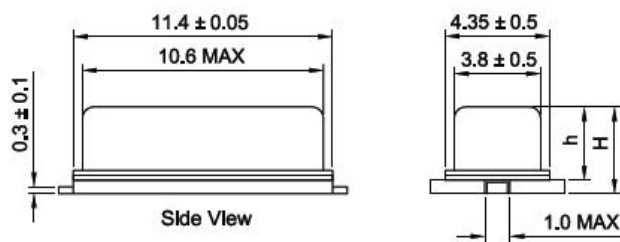

TYPE	H (SMD HIGH)	h (BODY HIGH)
S3	3.8 ± 0.3	3.3 ± 0.3
S2	3.0 ± 0.3	2.3 ± 0.3
S1	2.5 ± 0.3	2.0 ± 0.3

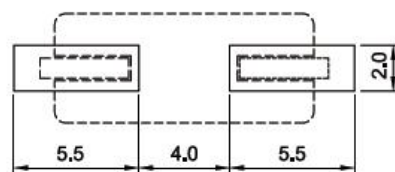
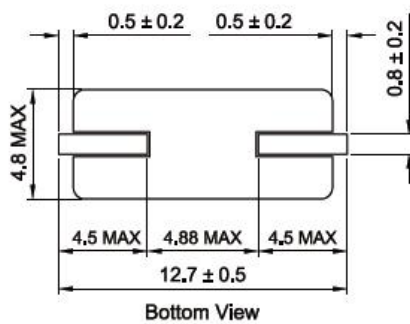

Units: mm

机械及环境性能 Environmental & Physical Characteristics

	Item	Condition	Standard
1.	Drop characteristics 跌落性	Free drop from 75cm height on a hard wooden board for 3 times. (Board is thickness more than 30 mm.)	Frequency change: $\leq 5\text{ppm}$ Rr as specification
2..	Shake characteristics 振动性	Shake frequency 10~55Hz, cycle 1~2 minutes, swing 1.5mm, direction x/y/z, all 30 minutes, test after 1 hours.	Frequency change: $\leq 5\text{ppm}$ Rr as specification
3.	Airproof characteristics 密封性	Put crystal into the pressure cabin with alcohol, keep pressure 0.4~0.5mpa 10 minutes, then take out and blow for 5 minutes	$IR \geq 500M\Omega$
4.	Weld characteristics 可焊性	$260 \pm 5^\circ\text{C}$, 3 seconds	90% exhibit tin ok
5.	Bend characteristics 弯曲性	5N, 90° , 3 times, test machine	no damage
6.	Humidity characteristics 恒温性	$+40 \pm 2^\circ\text{C}$ & 90%~95% R.H. 250 hours	Frequency change: $\leq 5\text{ppm}$ Rr as specification
7.	Low temperature characteristics 低温性	$-30 \pm 2^\circ\text{C}$, 250 hours, put in room temperature, test after 1 hours.	Frequency change: $\leq 5\text{ppm}$ Rr as specification
8.	High temperature characteristics 高温性	$+85 \pm 2^\circ\text{C}$, 250 hours, put in room temperature, test after 1 hours.	Frequency change: $\leq 5\text{ppm}$ Rr as specification

温度循环 Temperature cycling

Condition:

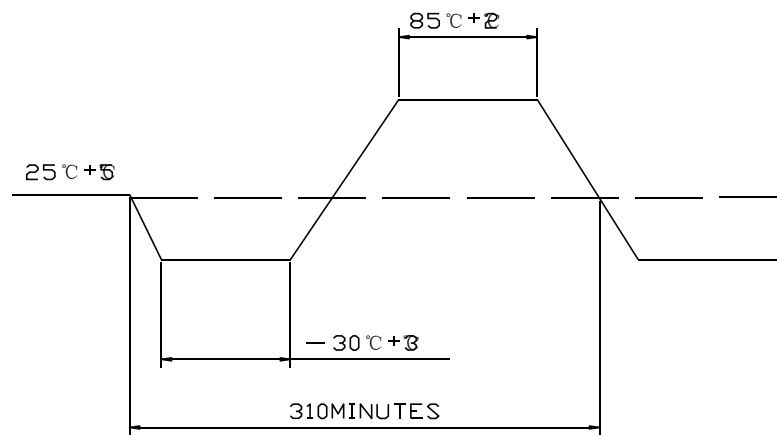

AFTER TEMPERATURE CYCLING

回流焊测试 Refluence examination

Condition:

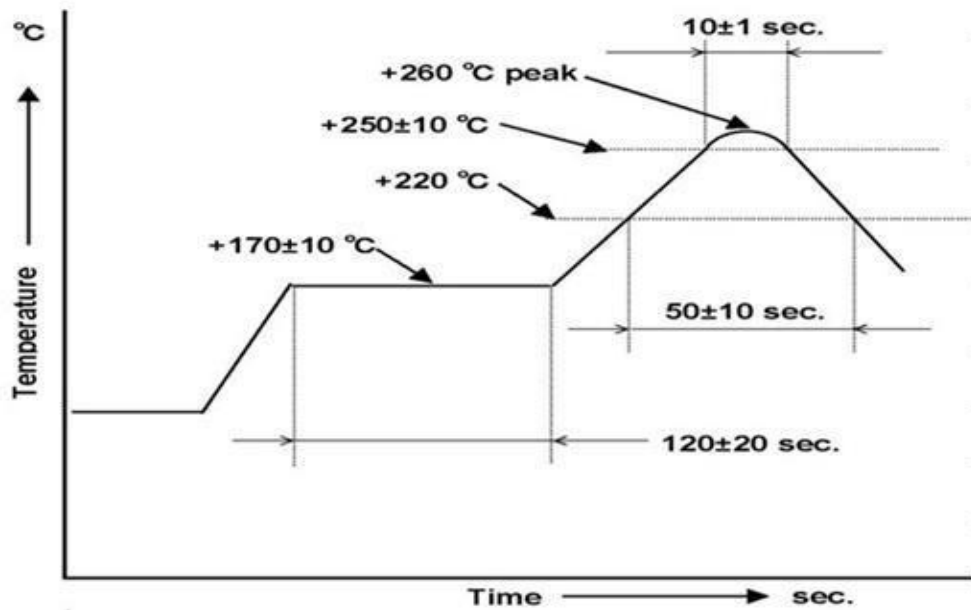

W1	24.5±0.20	16.5±0.20	16.5±0.20	12.5±0.20	12.5±0.20	12.5±0.20	12.5±0.20
T1	2.30±0.20	1.80±0.20	1.80±0.20	1.80±0.20	1.80±0.20	1.80±0.20	1.80±0.20

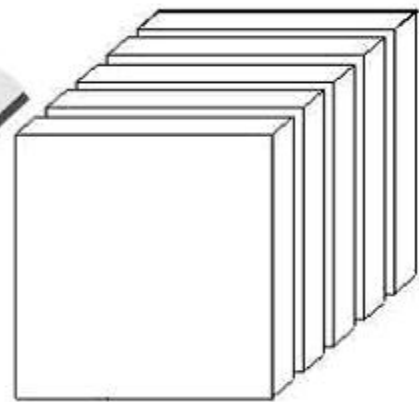
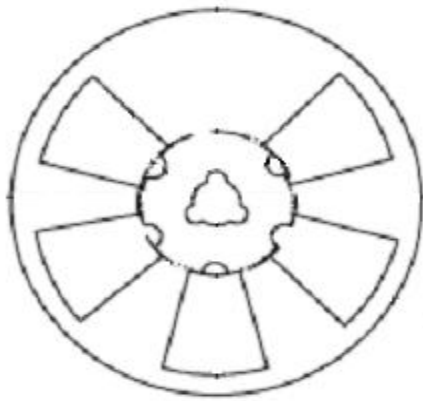

注：HC-49SMD系列产品包装盒和包装箱以实际尺寸为准。