

US-N300

Related Information

- General terms and conditions..... F-3
- Selection guideP.865~
- General precautions..... P.1595



panasonic.net/id/pidsx/global

Suitable for detecting transparent films or transparent bottles

Reliable detection of transparent objects

The sensor reliably detects transparent films or transparent objects.



Only 16 mm 0.630 in thick

Its 16 mm **0.630 in** thick compact body allows mounting in a narrow space.

Simple operation mode selection

The operation mode can be selected either sound-received-ON or sound-blocked-ON simply by changing the connection of the control input wire.

APPLICATIONS

Detecting transparent film or transparent glass

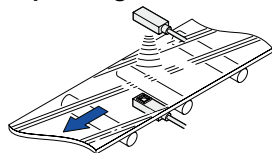

Detecting transparent bottles

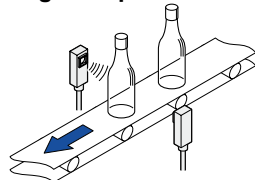

Detecting transparent and opaque objects

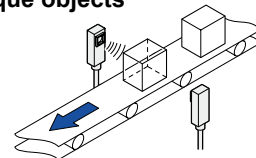

ORDER GUIDE

Type	Appearance	Sensing range	Model No. (Note)	Output
Thru-beam 5 m 16.404 ft 2 m 6.562 ft cable length cable length			US-N300	NPN transistor universal
			US-N300-C5	

Accessory

- MS-N30 (Sensor mounting bracket)

Two M4 (length 15 mm 0.591 in) screws with washers are attached.

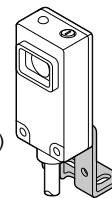

Note: Models whose model name on the product nameplate is followed by "P" are transmitter, while those whose model name is followed by "D" are receiver.

- Selection Guide
- Liquid Leak Detection
- Liquid Level Detection
- Water Detection
- Color Mark Detection
- Wafer Detection
- Ultrasonic
- Small / Slim Object Detection
- Obstacle Detection

US-N300

- FIBER SENSORS
- LASER SENSORS
- PHOTOELECTRIC SENSORS
- MICRO PHOTOELECTRIC SENSORS
- AREA SENSORS
- SAFETY LIGHT CURTAINS / SAFETY COMPONENTS
- PRESSURE / FLOW SENSORS
- INDUCTIVE PROXIMITY SENSORS
- PARTICULAR USE SENSORS
- SENSOR OPTIONS
- SIMPLE WIRE- SAVING UNITS
- WIRE- SAVING SYSTEMS
- MEASUREMENT SENSORS
- STATIC CONTROL DEVICES
- LASER MARKERS
- PLC
- HUMAN MACHINE INTERFACES
- ENERGY MANAGEMENT SOLUTIONS
- FA COMPONENTS
- MACHINE VISION SYSTEMS
- UV CURING SYSTEMS

SPECIFICATIONS

Type	Thru-beam	
Item	Model No.	US-N300
Sensing range	300 mm 11.811 in	
Sensing object	Transparent, translucent or opaque object: 20 × 20 mm 0.787 × 0.787 in or more, Hole: 10 × 10 mm 0.394 × 0.394 in or more	
Supply voltage	12 to 24 V DC ±10 % Ripple P-P 10 % or less	
Current consumption	Transmitter: 35 mA or less, Receiver: 35 mA or less	
Output	NPN transistor universal • Maximum sink current: 100 mA • Residual voltage: 1 V or less (at 100 mA sink current)	
	Output operation	Selectable either sound-received-ON or sound-blocked-ON by the control input
	Short-circuit protection	Incorporated
Response time	5 ms or less	
Operation indicator	Red LED (lights up when the output is ON)	
Sensitivity adjuster	Continuously variable adjuster	
Transmission frequency	220 kHz approx.	
Environmental resistance	Protection	IP62 (IEC)
	Ambient temperature	0 to +50 °C +32 to +122 °F (No dew condensation), Storage: -25 to +70 °C -13 to +158 °F
	Ambient humidity	35 to 85 % RH, Storage: 35 to 85 % RH
	Voltage withstandability	1,500 V AC for one min. between all supply terminals connected together and enclosure
	Insulation resistance	20 MΩ, or more, with 500 V DC megger between all supply terminals connected together and enclosure
	Vibration resistance	10 to 55 Hz frequency, 1.5 mm 0.059 in double amplitude in X, Y and Z directions for two hours each
	Shock resistance	100 m/s ² acceleration (10 G approx.) in X, Y and Z directions three times each
Material	Enclosure: Polycarbonate	
Cable	0.2 mm ² 4-core (transmitter: 2-core) cabtyre cable, 2 m 6.562 ft long	
Cable extension	Extension up to total 100 m 328.084 ft is possible, for both transmitter and receiver, with 0.2 mm ² , or more, cable.	
Weight	Transmitter: 80 g approx., Receiver: 85 g approx.	
Accessories	MS-N30 (Sensor mounting bracket): 1 set for transmitter and receiver, Adjusting screwdriver: 1 pc.	

Note: Where measurement conditions have not been specified precisely, the conditions used were an ambient temperature of +23 °C **+73.4 °F**.

I/O CIRCUIT AND WIRING DIAGRAMS

I/O circuit diagram

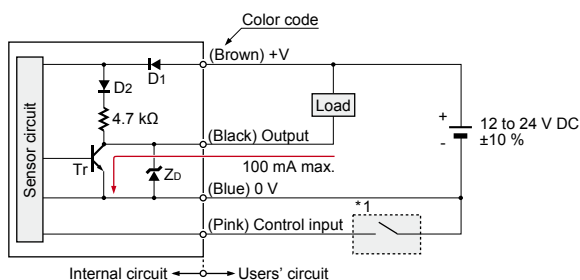

Note: The transmitter has only two power supply wires (+V and 0 V).

Symbols... D1: Reverse supply polarity protection diode
D2: Reverse current protection diode
ZD: Surge absorption zener diode
Tr: NPN output transistor

Wiring diagram

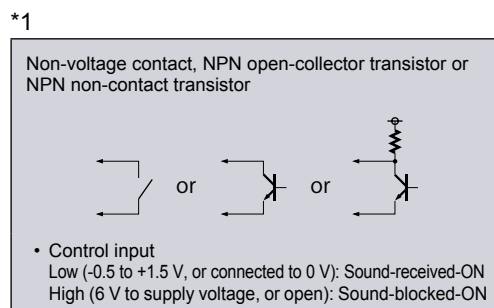
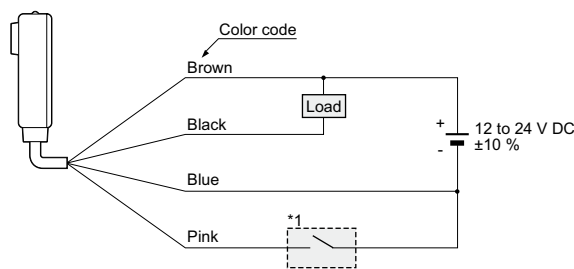

FIBER SENSORS

LASER SENSORS

PHOTO-ELECTRIC SENSORS

MICRO PHOTO-ELECTRIC SENSORS

AREA SENSORS

SAFETY LIGHT CURTAINS / SAFETY COMPONENTS

PRESSURE / FLOW SENSORS

INDUCTIVE PROXIMITY SENSORS

PARTICULAR USE SENSORS

SENSOR OPTIONS

SIMPLE WIRE-SAVING UNITS

WIRE-SAVING SYSTEMS

MEASUREMENT SENSORS

STATIC CONTROL DEVICES

LASER MARKERS

PLC

HUMAN MACHINE INTERFACES

ENERGY MANAGEMENT SOLUTIONS

FA COMPONENTS

MACHINE VISION SYSTEMS

UV CURING SYSTEMS

Selection Guide

Liquid Leak Detection

Liquid Level Detection

Water Detection

Color Mark Detection

Wafer Detection

Ultrasonic

Small / Sim Object Detection

Obstacle Detection

US-N300

SENSING CHARACTERISTICS (TYPICAL)

Parallel deviation

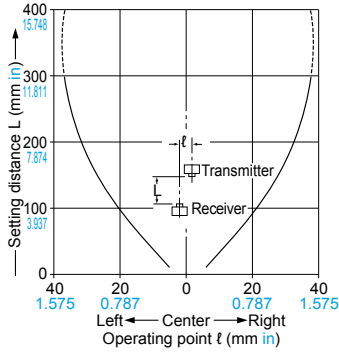

Angular deviation

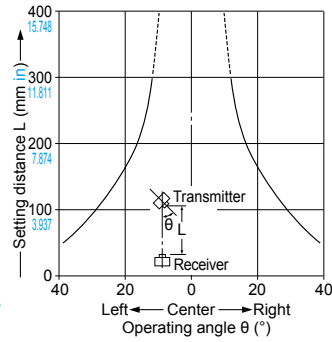

Sensing field

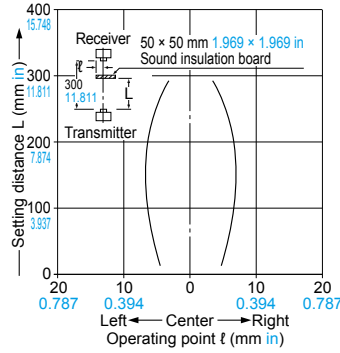

PRECAUTIONS FOR PROPER USE

Refer to p.1595 for general precautions.



- Never use this product as a sensing device for personnel protection.
- In case of using sensing devices for personnel protection, use products which meet laws and standards, such as OSHA, ANSI or IEC etc., for personnel protection applicable in each region or country.

Mounting

- The tightening torque should be 0.49 N·m or less.

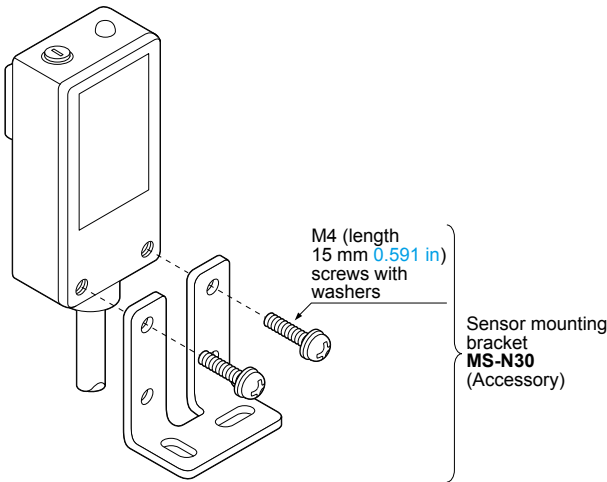

Influence of background objects

- If sensor heads are installed as shown in the figure below, the operation may become unstable by the reflected sound wave.

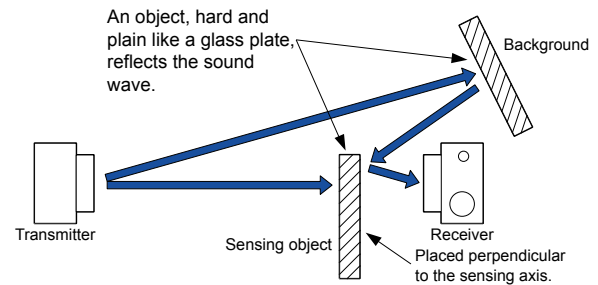

<Countermeasure>

The receiver should be placed away from the object and at an angle to it as shown below.

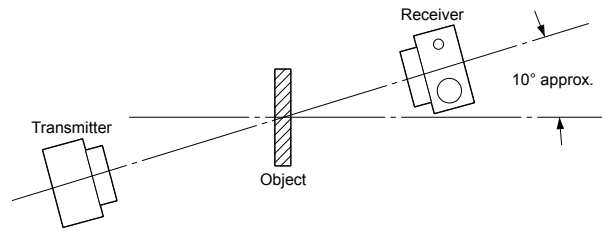

Sensitivity adjustment

- Normally, use the sensor at the maximum sensitivity. However, if the sensing is not proper due to surrounding objects (reflection from surrounding objects, etc.), adjust the sensitivity.

Influence of surrounding objects

Influence of an object parallel to the sensing axis

- If there is a wall or a curtain near the sensing axis, the sound reflection may cause the operation to be unstable.

<Countermeasure>

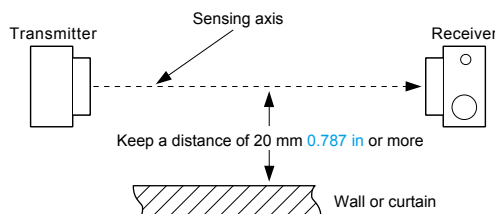

Mutual interference

- When two or more sensors are mounted close together, the sensors may not enter the "sound-blocked state" due to mutual interference.

<Countermeasure>

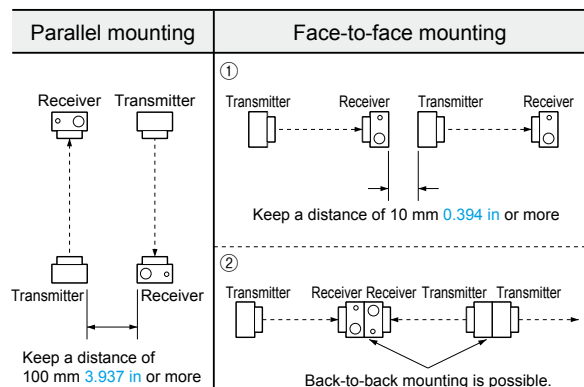

PRECAUTIONS FOR PROPER USE

Refer to p.1595 for general precautions.

Traveling speed and minimum sensing object width

- Minimum sensing object width is 20 × 20 mm **0.787 × 0.787 in** in the stationary condition.
The minimum sensing width of a traveling object is related to the traveling speed and the sensor response time by the following formula.

$$W = VT + A \text{ (m)}$$

- W : Minimum sensing object width (m)
- V : Traveling speed of the object (m/sec.)
- T : Sensor response time = 0.005 (sec.)
- A : Minimum sensing object width in the stationary condition = 0.02 **0.066 (m ft)**

Example: If V = 10 m **32.808 ft** /sec.
 $W = 10 \times 32.808 \times 0.005 + 0.02 = 0.07 \text{ m } \mathbf{0.230 \text{ ft}}$
 $= 70 \text{ mm } \mathbf{2.756 \text{ in}}$

Others

- Do not use during the initial transient time (50 ms) after the power supply is switched on.
- The ultrasonic sound propagates through the air. If the sensor is used at a place where air blows or the temperature suddenly changes (near a door, an air conditioner, etc.) the operation may become unstable. Avoid using **US-N300** at such places.
- Take care that the sensor may malfunction due to an intense extraneous sound, such as, metal impact sound.
- Do not expose the transmitting element or the receiving element to moisture or dust. It may affect the sensing operation.

DIMENSIONS (Unit: mm in)

The CAD data can be downloaded from our website.

US-N300 Sensor

Dimensions (mm / in):
 Front view: 12.6 (0.496), 12.1 (0.476), 8.3 (7.4), 0.327 (0.291), 28 (1.102), 13 (0.512), 60 (2.362), 7.5 (0.295), 4 (0.157), 20 (0.787), 13 (0.512), 20 (0.787).
 Side view: 20 (0.787), 16 (0.630), 20 (0.787).
 Cable: $\phi 4.8 \text{ } \phi 0.189$ cable, 2 m **6.562 ft** long.
 Mounting: 2-M4 × 0.7 **0.028** thru-hole threads.

MS-N30 Sensor mounting bracket (Accessory)

Assembly dimensions
 Mounting drawing with the receiver

Dimensions (mm / in):
 Front view: 12 (0.472), 4 (0.157), 19 (0.748), 4.3 (0.169), 20 (0.787), 4 (0.157), 30 (1.181), 20 (0.787), 8 (0.315), 37 (1.457), 32 (1.260), 20 (0.787), 12 (0.472), 4-ø4.3 $\phi 0.169$ holes, t2 (t 0.079).
 Side view: 20 (0.787), 4.3 (0.169), 4 (0.157), 32 (1.260), 39 (1.535), 4.3 (0.169), 0.157, 1.260, 1.102, 0.472, 5 (0.197), 20 (0.787), 30 (1.181), 5 (0.197), 19 (0.748), 35 (1.378), 39 (1.535), t2 (t 0.079).

Material: Cold rolled carbon steel (SPCC)
 Two M4 (length 15 mm **0.591 in**) screws with washers are attached.

- FIBER SENSORS
- LASER SENSORS
- PHOTO-ELECTRIC SENSORS
- MICRO PHOTO-ELECTRIC SENSORS
- AREA SENSORS
- SAFETY LIGHT CURTAINS / SAFETY COMPONENTS
- PRESSURE / FLOW SENSORS
- INDUCTIVE PROXIMITY SENSORS
- PARTICULAR USE SENSORS
- SENSOR OPTIONS
- SMALL WIRE-SAVING UNITS
- WIRE-SAVING SYSTEMS
- MEASUREMENT SENSORS
- STATIC CONTROL DEVICES
- LASER MARKERS
- PLC
- HUMAN MACHINE INTERFACES
- ENERGY MANAGEMENT SOLUTIONS
- FA COMPONENTS
- MACHINE VISION SYSTEMS
- UV CURING SYSTEMS

- Selection Guide
- Liquid Leak Detection
- Liquid Level Detection
- Water Detection
- Color Mark Detection
- Wafer Detection
- Ultrasonic
- Small / Sim Object Detection
- Obstacle Detection