

# Digital Fiber Sensor FX-410 SERIES

Related Information	■ General terms and conditions..... F-3	■ Selection guide..... P.3~
	■ SC..... P.987~	■ Glossary of terms..... P.1549~
	■ General precautions..... P.1552~	■ Korea's S-mark..... P.1602

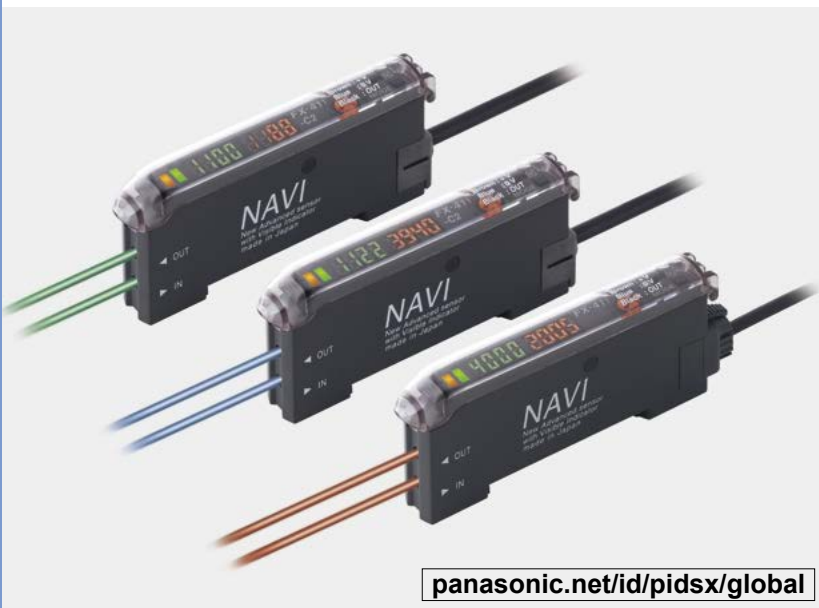

[panasonic.net/id/pidsx/global](http://panasonic.net/id/pidsx/global)

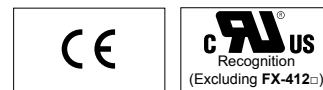

## Just “Look” and “Turn”, Simple, easy-to-use fiber sensor

### Incident light intensity and threshold value are displayed simultaneously

The incident light intensity and threshold value can be checked at the same time with no operations needed. In addition, no complex mode settings are needed when the values are adjusted.

### Easy-to-understand operating panel layout

The threshold value adjuster and operation mode switch are large and easy to see, and they can be operated with the same sensitivity as general-purpose photoelectric sensors. Functions which are not commonly used can be operated using a non-obtrusive setting switch.

### Adjustment variations according to the individual have been eliminated

Accurate control of the adjuster threshold values by using numerical values is possible due to the digital display. This allows anybody to perform the same settings.

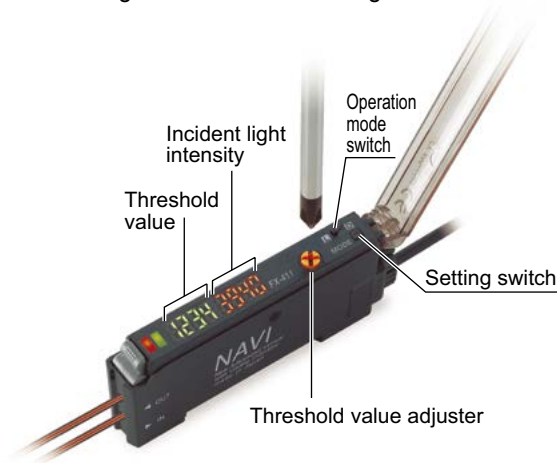

### Threshold values can be changed smoothly

This sensor uses the R.S.S.\* adjuster with a compact encoder inside. The sensitivity amount changes depending on the rotation speed of the adjuster, so that adjustment can be carried out speedily.

\* Rotation Speed Sensitivity

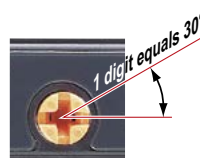
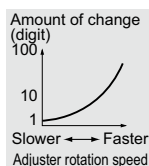
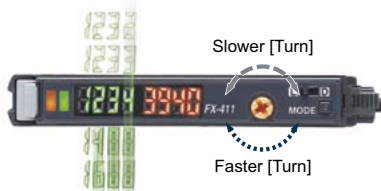

**Adjustment in units of 1 digit is also easy**  
No need for the fine changes in force required for photoelectric sensors.

- FIBER SENSORS
- LASER SENSORS
- PHOTOELECTRIC SENSORS
- MICRO PHOTOELECTRIC SENSORS
- AREA SENSORS
- SAFETY LIGHT CURTAINS / SAFETY COMPONENTS
- PRESSURE / FLOW SENSORS
- INDUCTIVE PROXIMITY SENSORS
- PARTICULAR USE SENSORS
- SENSOR OPTIONS
- SIMPLE WIRE-SAVING UNITS
- WIRE-SAVING SYSTEMS
- MEASUREMENT SENSORS
- STATIC CONTROL DEVICES
- LASER MARKERS
- PLC
- HUMAN MACHINE INTERFACES
- ENERGY MANAGEMENT SOLUTIONS
- FA COMPONENTS
- MACHINE VISION SYSTEMS
- UV CURING SYSTEMS

- Selection Guide
- Fibers
- Fiber Amplifiers
- Other Products

- FX-500
- FX-550
- FX-100
- FX-410

### Large endless adjuster

**New concept**

Standard screwdrivers can be used to turn the adjuster as well as precision screwdrivers. In addition, an “endless” mechanism is used which eliminates the possibility of any damage being caused by turning the adjuster too far.



### FX-412 can be turned by finger!

**New concept**

The adjuster can be turned directly by finger, without the need for a screwdriver.



### Beam power greatly increased to give strong performance under adverse environments

**Red LED type**

The beam power has been greatly increased. This means a longer sensing distance and less trouble from problems such as dust. These sensors have ample performance for workplace needs.

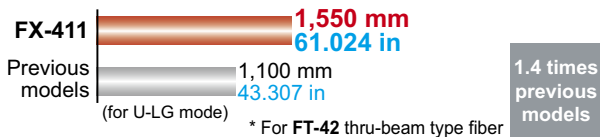

### Three types are available, with red, blue and green light

Different sensors can be selected to suit the application.



### Improved stability over both long and short terms

**Red LED type**

The red LED type sensors have a “four-chemical emitting element” which maintains stability of light emissions for long-term operation. Furthermore, all models have an “APC (Auto Power Control) circuit” which improves stability at times such as when the power is turned on. These features improve overall stability compared to previous models.

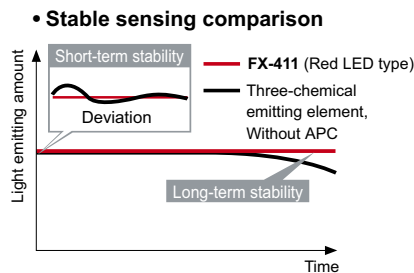

Color combinations that can be discerned during mark sensing

Mark color / Back-ground color	White	Yellow	Orange	Red	Green	Blue	Black
White		●	●	●●	●●●	●●●	●●●
Yellow	●		●	●●	●●●	●●●	●●●
Orange	●	●		●●	●●●	●●●	●●●
Red	●●	●	●		●	●●	●●
Green	●●●	●●●	●●●	●		●	●
Blue	●●●	●●●	●●●	●●	●		●
Black	●●●	●●●	●●●	●●	●	●	

●: Red LED type   ●: Blue LED type   ●: Green LED type

### Excellent workability and ease of maintenance

**Connector type**

The same quick-connection cable that is used for sensors such as the FX-300 series of digital fiber sensors is used. This means that they can be used together with other types of sensors such as laser sensors, and the number of power supply cables can be reduced.

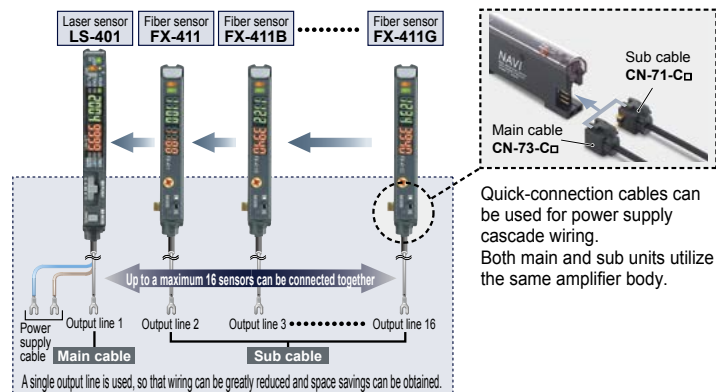

Quick-connection cables can be used for power supply cascade wiring. Both main and sub units utilize the same amplifier body.

The sensors can be connected together with other sensors such as the FX-300 series of digital fiber sensors and the GA-311 of inductive proximity sensors. In addition, the SC series of sensor PLC connection units with MIL connector compatibility can also be used to further reduce the amount of wiring (P.987~).

FIBER SENSORS

LASER SENSORS

PHOTOELECTRIC SENSORS

MICRO PHOTOELECTRIC SENSORS

AREA SENSORS

SAFETY LIGHT CURTAINS / SAFETY COMPONENTS

PRESSURE / FLOW SENSORS

INDUCTIVE PROXIMITY SENSORS

PARTICULAR USE SENSORS

SENSOR OPTIONS

SIMPLE WIRE-SAVING UNITS

WIRE-SAVING SYSTEMS

MEASUREMENT SENSORS

STATIC CONTROL DEVICES

LASER MARKERS

PLC

HUMAN MACHINE INTERFACES

ENERGY MANAGEMENT SOLUTIONS

FA COMPONENTS

MACHINE VISION SYSTEMS

UV CURING SYSTEMS

Selection Guide

Fibers

Fiber Amplifiers

Other Products

FX-500

FX-550

FX-100

FX-410

FIBER SENSORS

LASER SENSORS

PHOTOELECTRIC SENSORS

MICRO PHOTOELECTRIC SENSORS

AREA SENSORS

SAFETY LIGHT CURTAINS / SAFETY COMPONENTS

PRESSURE / FLOW SENSORS

INDUCTIVE PROXIMITY SENSORS

PARTICULAR USE SENSORS

SENSOR OPTIONS

SIMPLE WIRE-SAVING UNITS

WIRE-SAVING SYSTEMS

MEASUREMENT SENSORS

STATIC CONTROL DEVICES

LASER MARKERS

PLC

HUMAN MACHINE INTERFACES

ENERGY MANAGEMENT SOLUTIONS

FA COMPONENTS

MACHINE VISION SYSTEMS

UV CURING SYSTEMS

Selection Guide

Fibers

Fiber Amplifiers

Other Products

**FX-500**

**FX-550**

**FX-100**

**FX-410**

**Contributing to device miniaturization**

This fiber sensor is the smallest among the dual digital display types, contributing to device miniaturization.



**Equipped with 3 types timers**

Equipped with OFF-delay / ON-delay / ONE SHOT timer. (Timer period: 1 ms to 3 sec. approx.)

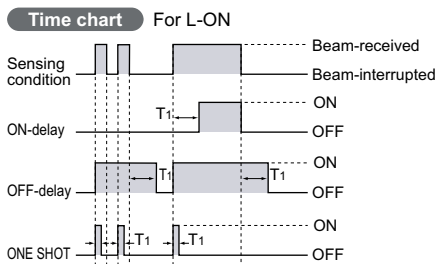

**Interference prevention for up to 8 sets fiber heads (for U-LG)**

The optical communication function allows up to a maximum of eight sets of fiber heads (four sets for FAST and STD settings) to be installed in contact with each other without mutual interference occurring. (Set automatically when power is turned on.)

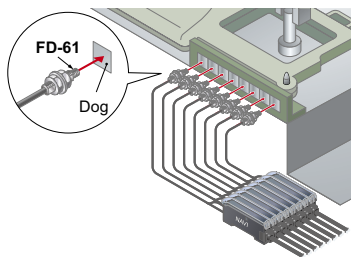

**Key lock function prevents wrong operation**

This prevents the operator from changing the threshold value by mistake.

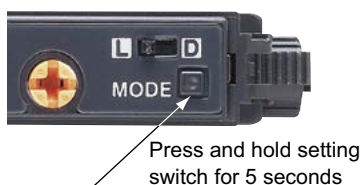

**Ideal for dealing with saturation / Light-emitting amount selection function**

**Red LED type** **New concept**

In cases where the incoming light level can become saturated, such as during close-range sensing or when sensing transparent or minute objects, the sensor's light-emitting amount can be adjusted to provide more stable sensing without changing the response time.

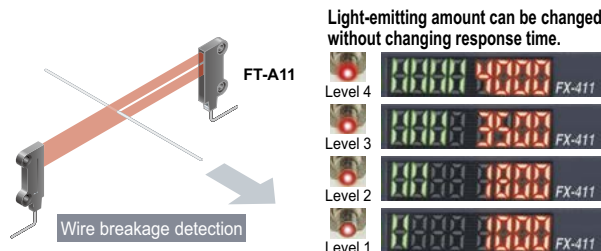

**Digital display upside-down / off function**

The digital display can be turned upside-down if required to suit the setup location. In addition, a stability indicator is also provided, so that the amount of light-receiving excess can be checked even when the display is turned off.

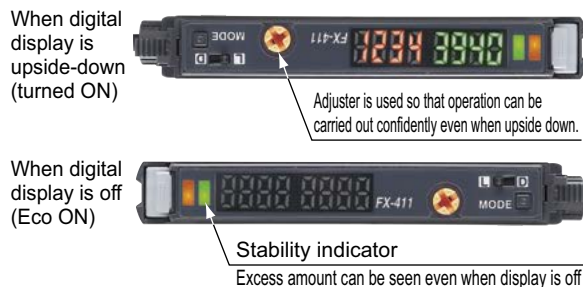

**Hold function**

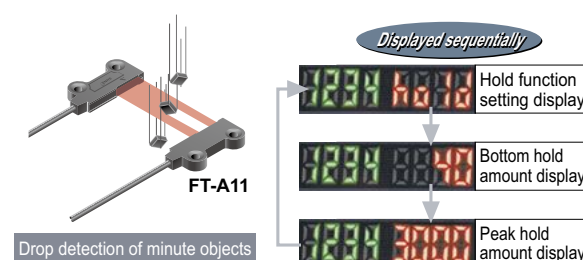

Peak and bottom hold values for the incident light intensity can be displayed. This is useful for checking the incident light intensity during tasks such as drop detection.

In addition, the peak and bottom values can be checked while looking at the threshold value, which makes adjustment much easier.



**ORDER GUIDE**

**Amplifiers** Quick-connection cable is not supplied with the amplifier. Please order it separately.

Type	Appearance	Model No.	Emitting element	Output
NPN output		<b>FX-411</b>	Red LED	NPN open-collector transistor
		<b>FX-411B</b>	Blue LED	
		<b>FX-411G</b>	Green LED	
PNP output		<b>FX-411P</b>	Red LED	PNP open-collector transistor
		<b>FX-411BP</b>	Blue LED	
		<b>FX-411GP</b>	Green LED	
NPN output		<b>FX-412 (Note)</b>	Red LED	NPN open-collector transistor
		<b>FX-412B (Note)</b>	Blue LED	
		<b>FX-412G (Note)</b>	Green LED	

Note: The **FX-412** has a threshold value adjuster that can be adjusted with your fingers.

**Quick-connection cables** Quick-connection cable is not supplied with the amplifier. Please order it separately.

Type	Model No.	Description	
Main cable (3-core)	<b>CN-73-C1</b>	Length: 1 m <b>3.281 ft</b>	0.2 mm <sup>2</sup> 3-core cabtyre cable, with connector on one end Cable outer diameter: $\varnothing$ 3.3 mm $\varnothing$ 0.130 in
	<b>CN-73-C2</b>	Length: 2 m <b>6.562 ft</b>	
	<b>CN-73-C5</b>	Length: 5 m <b>16.404 ft</b>	
Sub cable (1-core)	<b>CN-71-C1</b>	Length: 1 m <b>3.281 ft</b>	0.2 mm <sup>2</sup> 1-core cabtyre cable, with connector on one end Cable outer diameter: $\varnothing$ 3.3 mm $\varnothing$ 0.130 in
	<b>CN-71-C2</b>	Length: 2 m <b>6.562 ft</b>	
	<b>CN-71-C5</b>	Length: 5 m <b>16.404 ft</b>	

**Main cable**

- **CN-73-C**

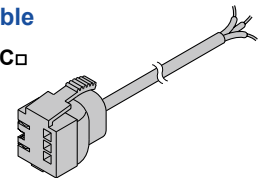

**Sub cable**

- **CN-71-C**

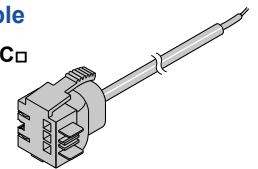

**End plates** End plates are not supplied with the amplifier. Please order them separately when the amplifiers are mounted in cascade.

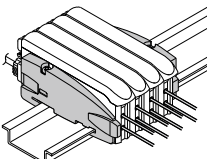
Appearance	Model No.	Description
	<b>MS-DIN-E</b>	When amplifiers are mounted in cascade, or when an amplifier moves depending on the way it is installed on a DIN rail, these end plates clamp amplifiers into place on both sides. Make sure to use end plates when cascading multiple amplifiers together. <b>2 pcs. per set</b>

**OPTIONS**

Designation	Model No.	Description
Amplifier mounting bracket	<b>MS-DIN-2</b>	Mounting bracket for amplifier
Fiber amplifier protection seal	<b>FX-MB1</b>	10 sets of 2 communication window seals and 1 connector seal Communication window seal: It prevents malfunction due to transmission signal from another amplifier, as well as, prevents effect on another amplifier. Connector seal: It prevents contact of any metal, etc., with the pins of the quick-connection cable.

**Amplifier mounting bracket**

- **MS-DIN-2**

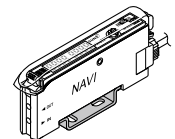

**Fiber amplifier protection seal**

- **FX-MB1**

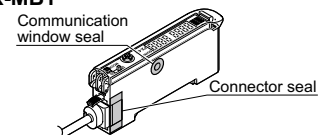

FIBER SENSORS

LASER SENSORS

PHOTO-ELECTRIC SENSORS

MICRO PHOTO-ELECTRIC SENSORS

AREA SENSORS

SAFETY LIGHT CURTAINS / SAFETY COMPONENTS

PRESSURE / FLOW SENSORS

INDUCTIVE PROXIMITY SENSORS

PARTICULAR USE SENSORS

SENSOR OPTIONS

SIMPLE WIRE-SAVING UNITS

WIRE-SAVING SYSTEMS

MEASUREMENT SENSORS

STATIC CONTROL DEVICES

LASER MARKERS

PLC

HUMAN MACHINE INTERFACES

ENERGY MANAGEMENT SOLUTIONS

FA COMPONENTS

MACHINE VISION SYSTEMS

UV CURING SYSTEMS

Selection Guide

Fibers

Fiber Amplifiers

Other Products

**FX-500**

**FX-550**

**FX-100**

**FX-410**

## LIST OF FIBERS

### Thru-beam type (one pair set)



Fibers are listed in alphabetic order. Refer to "Fiber Selection p.5~" for details of each fiber.

Model No.	Sensing range (mm in) (Note 1)									Dimensions
	Red LED			Blue LED			Green LED			
	U-LG	STD	FAST	U-LG	STD	FAST	U-LG	STD	FAST	
<b>FT-140</b>	19,600 <a href="#">771.654</a> (Note 2)	16,000 <a href="#">629.921</a>	15,000 <a href="#">590.551</a>	14,000 <a href="#">551.181</a>	3,300 <a href="#">129.921</a>	2,200 <a href="#">86.614</a>	9,500 <a href="#">374.016</a>	2,500 <a href="#">98.425</a>	1,800 <a href="#">70.866</a>	P.63
<b>FT-30</b>	600 <a href="#">23.622</a>	145 <a href="#">5.709</a>	95 <a href="#">3.740</a>	90 <a href="#">3.543</a>	24 <a href="#">0.945</a>	15 <a href="#">0.591</a>	45 <a href="#">1.772</a>	12 <a href="#">0.472</a>	8 <a href="#">0.315</a>	P.63
<b>FT-31</b>	540 <a href="#">21.260</a>	140 <a href="#">5.512</a>	85 <a href="#">3.346</a>	85 <a href="#">3.346</a>	20 <a href="#">0.787</a>	14 <a href="#">0.551</a>	38 <a href="#">1.496</a>	10 <a href="#">0.394</a>	7 <a href="#">0.276</a>	P.63
<b>FT-31S</b>	540 <a href="#">21.260</a>	140 <a href="#">5.512</a>	85 <a href="#">3.346</a>	85 <a href="#">3.346</a>	20 <a href="#">0.787</a>	14 <a href="#">0.551</a>	38 <a href="#">1.496</a>	10 <a href="#">0.394</a>	7 <a href="#">0.276</a>	P.63
<b>FT-31W</b>	380 <a href="#">14.961</a>	80 <a href="#">3.150</a>	55 <a href="#">2.165</a>	53 <a href="#">2.087</a>	16 <a href="#">0.630</a>	9 <a href="#">0.354</a>	28 <a href="#">1.102</a>	7 <a href="#">0.276</a>	4 <a href="#">0.157</a>	P.63
<b>FT-32</b>	3,600 <a href="#">141.732</a> (Note 2)	1,190 <a href="#">46.850</a>	870 <a href="#">34.252</a>	860 <a href="#">33.858</a>	220 <a href="#">8.661</a>	145 <a href="#">5.709</a>	450 <a href="#">17.717</a>	120 <a href="#">4.724</a>	80 <a href="#">3.150</a>	P.63
<b>FT-40</b>	1,600 <a href="#">62.922</a>	345 <a href="#">13.583</a>	245 <a href="#">9.646</a>	250 <a href="#">9.843</a>	65 <a href="#">2.559</a>	45 <a href="#">1.772</a>	140 <a href="#">5.512</a>	40 <a href="#">1.575</a>	25 <a href="#">0.984</a>	P.63
<b>FT-42</b>	1,550 <a href="#">61.024</a>	340 <a href="#">13.386</a>	240 <a href="#">9.449</a>	230 <a href="#">9.055</a>	60 <a href="#">2.362</a>	40 <a href="#">1.575</a>	125 <a href="#">4.921</a>	33 <a href="#">1.299</a>	22 <a href="#">0.866</a>	P.63
<b>FT-42S</b>	1,550 <a href="#">61.024</a>	340 <a href="#">13.386</a>	240 <a href="#">9.449</a>	230 <a href="#">9.055</a>	60 <a href="#">2.362</a>	40 <a href="#">1.575</a>	125 <a href="#">4.921</a>	33 <a href="#">1.299</a>	22 <a href="#">0.866</a>	P.63
<b>FT-42W</b>	1,300 <a href="#">51.181</a>	290 <a href="#">11.417</a>	210 <a href="#">8.268</a>	220 <a href="#">8.661</a>	57 <a href="#">2.244</a>	33 <a href="#">1.299</a>	110 <a href="#">4.331</a>	32 <a href="#">1.260</a>	19 <a href="#">0.748</a>	P.63
<b>FT-43</b>	2,200 <a href="#">86.614</a>	450 <a href="#">17.717</a>	310 <a href="#">12.205</a>	460 <a href="#">18.110</a>	120 <a href="#">4.724</a>	75 <a href="#">2.953</a>	250 <a href="#">9.843</a>	62 <a href="#">2.441</a>	44 <a href="#">1.732</a>	P.64
<b>FT-45X</b>	1,600 <a href="#">62.992</a>	370 <a href="#">14.567</a>	280 <a href="#">11.024</a>	260 <a href="#">10.236</a>	64 <a href="#">2.520</a>	45 <a href="#">1.772</a>	130 <a href="#">5.118</a>	34 <a href="#">1.339</a>	23 <a href="#">0.906</a>	P.64
<b>FT-A11</b>	3,600 <a href="#">141.732</a> (Note 2)	2,400 <a href="#">94.488</a>	1,800 <a href="#">70.866</a>	1,300 <a href="#">51.181</a>	350 <a href="#">13.780</a>	220 <a href="#">8.661</a>	770 <a href="#">30.315</a>	190 <a href="#">7.480</a>	120 <a href="#">4.724</a>	P.64
<b>FT-A11W</b>	3,600 <a href="#">141.732</a> (Note 2)	2,500 <a href="#">98.425</a>	2,000 <a href="#">78.740</a>	1,300 <a href="#">51.181</a>	350 <a href="#">13.780</a>	220 <a href="#">8.661</a>	550 <a href="#">21.654</a>	150 <a href="#">5.906</a>	130 <a href="#">5.118</a>	P.64
<b>FT-A32</b>	3,600 <a href="#">141.732</a> (Note 2)	3,600 <a href="#">141.732</a> (Note 2)	3,600 <a href="#">141.732</a> (Note 2)	2,500 <a href="#">98.425</a>	750 <a href="#">29.528</a>	380 <a href="#">14.961</a>	1,500 <a href="#">59.055</a>	220 <a href="#">8.661</a>	130 <a href="#">5.118</a>	P.64
<b>FT-A32W</b>	3,600 <a href="#">141.732</a> (Note 2)	3,600 <a href="#">141.732</a> (Note 2)	3,600 <a href="#">141.732</a> (Note 2)	3,400 <a href="#">133.858</a>	800 <a href="#">31.496</a>	470 <a href="#">18.504</a>	2,100 <a href="#">82.677</a>	330 <a href="#">12.992</a>	140 <a href="#">5.512</a>	P.64
<b>FT-AL05</b>	1,100 <a href="#">43.307</a>	240 <a href="#">9.449</a>	180 <a href="#">7.087</a>	220 <a href="#">8.661</a>	55 <a href="#">2.165</a>	35 <a href="#">1.378</a>	125 <a href="#">4.921</a>	30 <a href="#">1.181</a>	20 <a href="#">0.787</a>	P.64
<b>FT-E13</b>	30 <a href="#">1.181</a>	7 <a href="#">0.276</a>	5 <a href="#">0.197</a>	2.5 <a href="#">0.098</a>	—	—	1 <a href="#">0.039</a>	—	—	P.64
<b>FT-E23</b>	110 <a href="#">4.331</a>	20 <a href="#">0.787</a>	15 <a href="#">0.591</a>	12 <a href="#">0.472</a>	3 <a href="#">0.118</a>	2 <a href="#">0.079</a>	6 <a href="#">0.236</a>	1 <a href="#">0.039</a>	—	P.64
<b>FT-H13-FM2</b>	1,100 <a href="#">43.307</a>	280 <a href="#">11.024</a>	200 <a href="#">7.874</a>	50 <a href="#">1.969</a>	13 <a href="#">0.512</a>	9 <a href="#">0.354</a>	150 <a href="#">5.906</a>	16 <a href="#">0.630</a>	10 <a href="#">0.394</a>	P.65
<b>FT-H20-J20-S</b> (Note 3)	700 <a href="#">27.559</a>	160 <a href="#">6.299</a>	110 <a href="#">4.331</a>	120 <a href="#">4.724</a>	20 <a href="#">0.787</a>	—	60 <a href="#">2.362</a>	—	—	P.65
<b>FT-H20-J30-S</b> (Note 3)	700 <a href="#">27.559</a>	160 <a href="#">6.299</a>	110 <a href="#">4.331</a>	120 <a href="#">4.724</a>	20 <a href="#">0.787</a>	—	60 <a href="#">2.362</a>	—	—	P.65
<b>FT-H20-J50-S</b> (Note 3)	700 <a href="#">27.559</a>	160 <a href="#">6.299</a>	110 <a href="#">4.331</a>	120 <a href="#">4.724</a>	20 <a href="#">0.787</a>	—	60 <a href="#">2.362</a>	—	—	P.65
<b>FT-H20-M1</b>	550 <a href="#">21.654</a>	150 <a href="#">5.906</a>	100 <a href="#">3.937</a>	100 <a href="#">3.937</a>	25 <a href="#">0.984</a>	20 <a href="#">0.787</a>	65 <a href="#">2.559</a>	17 <a href="#">0.669</a>	12 <a href="#">0.472</a>	P.65
<b>FT-H20-VJ50-S</b> (Note 3)	1,100 <a href="#">43.307</a>	240 <a href="#">9.449</a>	170 <a href="#">6.693</a>	170 <a href="#">6.693</a>	35 <a href="#">1.378</a>	—	90 <a href="#">3.543</a>	—	—	P.65
<b>FT-H20-VJ80-S</b> (Note 3)	1,100 <a href="#">43.307</a>	240 <a href="#">9.449</a>	170 <a href="#">6.693</a>	170 <a href="#">6.693</a>	35 <a href="#">1.378</a>	—	90 <a href="#">3.543</a>	—	—	P.65
<b>FT-H20W-M1</b>	400 <a href="#">15.748</a>	110 <a href="#">4.331</a>	80 <a href="#">3.15</a>	75 <a href="#">2.953</a>	19 <a href="#">0.748</a>	13 <a href="#">0.512</a>	58 <a href="#">2.283</a>	13 <a href="#">0.512</a>	9 <a href="#">0.354</a>	P.65
<b>FT-H30-M1V-S</b> (Note 4)	390 <a href="#">15.354</a>	100 <a href="#">3.937</a>	70 <a href="#">2.756</a>	75 <a href="#">2.953</a>	20 <a href="#">0.787</a>	15 <a href="#">0.591</a>	55 <a href="#">2.165</a>	13 <a href="#">0.512</a>	10 <a href="#">0.394</a>	P.65
<b>FT-H35-M2</b>	600 <a href="#">23.622</a>	150 <a href="#">5.906</a>	110 <a href="#">4.331</a>	115 <a href="#">4.528</a>	28 <a href="#">1.102</a>	20 <a href="#">0.787</a>	90 <a href="#">3.543</a>	20 <a href="#">0.787</a>	14 <a href="#">0.551</a>	P.65
<b>FT-H35-M2S6</b>	600 <a href="#">23.622</a>	150 <a href="#">5.906</a>	110 <a href="#">4.331</a>	115 <a href="#">4.528</a>	28 <a href="#">1.102</a>	20 <a href="#">0.787</a>	90 <a href="#">3.543</a>	20 <a href="#">0.787</a>	14 <a href="#">0.551</a>	P.65
<b>FT-HL80Y</b>	3,500 <a href="#">137.795</a> (Note 2)	800 <a href="#">31.496</a>	550 <a href="#">21.654</a>	150 <a href="#">5.906</a>	35 <a href="#">1.378</a>	20 <a href="#">0.787</a>	200 <a href="#">7.874</a>	55 <a href="#">2.165</a>	35 <a href="#">1.378</a>	P.66
<b>FT-KS40</b>	3,600 <a href="#">141.732</a> (Note 2)	2,000 <a href="#">78.740</a>	1,900 <a href="#">74.803</a>	1,000 <a href="#">39.370</a>	270 <a href="#">10.630</a>	190 <a href="#">7.480</a>	590 <a href="#">23.228</a>	130 <a href="#">5.118</a>	53 <a href="#">2.087</a>	P.66
<b>FT-KV26</b>	880 <a href="#">34.646</a>	170 <a href="#">6.693</a>	120 <a href="#">4.724</a>	130 <a href="#">5.118</a>	31 <a href="#">1.220</a>	—	90 <a href="#">3.543</a>	18 <a href="#">0.709</a>	—	P.66
<b>FT-KV26H1</b>	790 <a href="#">31.102</a>	150 <a href="#">5.906</a>	100 <a href="#">3.937</a>	115 <a href="#">4.528</a>	28 <a href="#">1.102</a>	—	80 <a href="#">3.150</a>	16 <a href="#">0.630</a>	—	P.66
<b>FT-KV40</b>	3,600 <a href="#">141.732</a> (Note 2)	1,700 <a href="#">66.929</a>	1,300 <a href="#">51.181</a>	1,200 <a href="#">47.244</a>	310 <a href="#">12.205</a>	190 <a href="#">7.480</a>	800 <a href="#">31.496</a>	190 <a href="#">7.480</a>	120 <a href="#">4.724</a>	P.66
<b>FT-KV40W</b>	3,600 <a href="#">141.732</a> (Note 2)	1,600 <a href="#">62.992</a>	1,100 <a href="#">43.307</a>	900 <a href="#">35.433</a>	270 <a href="#">10.630</a>	140 <a href="#">5.512</a>	420 <a href="#">16.535</a>	100 <a href="#">3.937</a>	65 <a href="#">2.559</a>	P.66
<b>FT-L80Y</b>	3,500 <a href="#">137.795</a> (Note 2)	900 <a href="#">35.433</a>	600 <a href="#">23.622</a>	250 <a href="#">9.843</a>	60 <a href="#">2.362</a>	40 <a href="#">1.575</a>	300 <a href="#">11.811</a>	70 <a href="#">2.756</a>	45 <a href="#">1.772</a>	P.66
<b>FT-R31</b>	380 <a href="#">14.961</a>	79 <a href="#">3.110</a>	56 <a href="#">2.205</a>	80 <a href="#">3.150</a>	20 <a href="#">0.787</a>	13 <a href="#">0.512</a>	38 <a href="#">1.496</a>	10 <a href="#">0.394</a>	7 <a href="#">0.276</a>	P.66
<b>FT-R40</b>	1,200 <a href="#">47.244</a>	240 <a href="#">9.449</a>	170 <a href="#">6.693</a>	200 <a href="#">7.874</a>	50 <a href="#">1.969</a>	32 <a href="#">1.260</a>	100 <a href="#">3.937</a>	28 <a href="#">1.102</a>	19 <a href="#">0.748</a>	P.66
<b>FT-R41W</b>	1,200 <a href="#">47.244</a>	290 <a href="#">11.417</a>	200 <a href="#">7.874</a>	220 <a href="#">8.661</a>	57 <a href="#">2.244</a>	33 <a href="#">1.299</a>	100 <a href="#">3.937</a>	26 <a href="#">1.024</a>	18 <a href="#">0.709</a>	P.66
<b>FT-R42W</b>	3,600 <a href="#">141.732</a> (Note 2)	990 <a href="#">38.976</a>	740 <a href="#">29.134</a>	310 <a href="#">12.205</a>	75 <a href="#">2.953</a>	58 <a href="#">2.283</a>	270 <a href="#">10.630</a>	70 <a href="#">2.756</a>	50 <a href="#">1.969</a>	P.66
<b>FT-R43</b>	1,200 <a href="#">47.244</a>	230 <a href="#">9.055</a>	160 <a href="#">6.299</a>	200 <a href="#">7.874</a>	50 <a href="#">1.969</a>	32 <a href="#">1.260</a>	100 <a href="#">3.937</a>	26 <a href="#">1.024</a>	18 <a href="#">0.709</a>	P.67
<b>FT-R44Y</b>	1,200 <a href="#">47.244</a>	230 <a href="#">9.055</a>	160 <a href="#">6.299</a>	200 <a href="#">7.874</a>	50 <a href="#">1.969</a>	32 <a href="#">1.260</a>	100 <a href="#">3.937</a>	26 <a href="#">1.024</a>	18 <a href="#">0.709</a>	P.67
<b>FT-R60Y</b>	3,600 <a href="#">141.732</a> (Note 2)	750 <a href="#">29.528</a>	540 <a href="#">21.260</a>	560 <a href="#">22.047</a>	140 <a href="#">5.512</a>	90 <a href="#">3.543</a>	290 <a href="#">11.417</a>	75 <a href="#">2.953</a>	50 <a href="#">1.969</a>	P.67
<b>FT-S11</b>	150 <a href="#">5.906</a>	30 <a href="#">1.181</a>	20 <a href="#">0.787</a>	21 <a href="#">0.827</a>	5 <a href="#">0.197</a>	3.5 <a href="#">0.138</a>	12 <a href="#">0.472</a>	2 <a href="#">0.079</a>	1.5 <a href="#">0.059</a>	P.67
<b>FT-S20</b>	600 <a href="#">23.622</a>	145 <a href="#">5.709</a>	95 <a href="#">3.740</a>	90 <a href="#">3.543</a>	24 <a href="#">0.945</a>	15 <a href="#">0.591</a>	45 <a href="#">1.772</a>	12 <a href="#">0.472</a>	8 <a href="#">0.315</a>	P.67
<b>FT-S21</b>	540 <a href="#">21.260</a>	140 <a href="#">5.512</a>	85 <a href="#">3.346</a>	85 <a href="#">3.346</a>	20 <a href="#">0.787</a>	14 <a href="#">0.551</a>	38 <a href="#">1.496</a>	10 <a href="#">0.394</a>	7 <a href="#">0.276</a>	P.67

Notes: 1) Note that the sensing range of the free-cut type fiber may be reduced by 20 % max. depending upon how the fiber is cut.

2) The fiber cable length practically limits the sensing range.

3) Heat-resistant joint fibers and ordinary-temperature fibers (FT-42) are sold as a set. Please refer to p.37 for details.

4) Sold as a set comprising vacuum type fiber + photo-terminal (FV-BR1) + fiber at atmospheric side (FT-J8). Please refer to p.39 for details.

**LIST OF FIBERS**

**Thru-beam type (one pair set)**



Fibers are listed in alphabetic order. Refer to “Fiber Selection p.5~” for details of each fiber.

Model No.	Sensing range (mm in) (Note 1)									Dimensions
	Red LED			Blue LED			Green LED			
	U-LG	STD	FAST	U-LG	STD	FAST	U-LG	STD	FAST	
<b>FT-S21W</b>	380 14.961	80 3.150	55 2.165	53 2.087	16 0.630	9 0.354	28 1.102	7 0.276	4 0.157	P.67
<b>FT-S22</b>	910 35.827	190 7.480	140 5.512	110 4.331	29 1.142	17 0.669	70 2.756	18 0.709	11 0.433	P.67
<b>FT-S30</b>	1,600 62.992	345 13.583	245 9.646	250 9.843	65 2.559	45 1.772	140 5.512	40 1.575	25 0.984	P.67
<b>FT-S31W</b>	1,300 51.181	290 11.417	210 8.268	220 8.661	57 2.244	33 1.299	110 4.331	32 1.260	19 0.748	P.68
<b>FT-S32</b>	3,600 141.732 (Note 2)	920 36.220	670 26.378	700 27.559	180 7.087	110 4.331	400 15.748	92 3.622	62 2.441	P.68
<b>FT-V23</b>	720 28.346	140 5.512	100 3.937	120 4.724	30 1.181	20 0.787	65 2.559	16 0.630	9 0.354	P.68
<b>FT-V24W</b>	140 5.512	25 0.984	20 0.787	18 0.709	2 0.079	—	5 0.197	—	—	P.68
<b>FT-V25</b>	360 14.173	70 2.756	50 1.969	57 2.244	10 0.394	7 0.276	28 1.102	8 0.315	5 0.197	P.68
<b>FT-V30</b>	770 30.315	160 6.299	120 4.724	210 8.268	47 1.850	28 1.102	100 3.937	22 0.866	10 0.394	P.68
<b>FT-V40</b>	3,600 141.732 (Note 2)	950 37.402	730 28.740	810 31.890	190 7.480	130 5.118	500 19.685	115 4.528	81 3.189	P.68
<b>FT-V80Y</b>	1,500 59.055	350 13.780	250 9.843	240 9.449	55 2.165	35 1.378	180 7.087	38 1.496	24 0.945	P.68
<b>FT-Z20HBW</b>	390 15.354	80 3.150	55 2.165	64 2.520	16 0.630	10 0.394	30 1.181	7 0.276	5 0.197	P.68
<b>FT-Z20W</b>	1,300 51.181	270 10.630	190 7.480	170 6.693	39 1.535	23 0.906	92 3.622	19 0.748	11 0.433	P.68
<b>FT-Z30</b>	3,100 122.047	660 25.984	480 18.898	640 25.197	160 6.299	100 3.937	320 12.598	87 3.425	59 2.323	P.68
<b>FT-Z30E</b>	3,600 141.732 (Note 2)	1,200 47.244	920 36.220	960 37.795	250 9.843	160 6.299	460 18.110	120 4.724	83 3.268	P.69
<b>FT-Z30EW</b>	3,600 141.732 (Note 2)	590 23.228	430 16.929	940 37.008	180 7.087	110 4.331	400 15.748	85 3.346	56 2.205	P.69
<b>FT-Z30H</b>	3,600 141.732 (Note 2)	1,300 51.181	950 37.402	1,100 43.307	290 11.417	170 6.693	580 22.835	150 5.906	100 3.937	P.69
<b>FT-Z30HW</b>	3,600 141.732 (Note 2)	1,300 51.181	950 37.402	940 37.008	180 7.087	110 4.331	400 15.748	85 3.346	56 2.205	P.69
<b>FT-Z30W</b>	2,400 94.488	540 21.260	390 15.354	490 19.291	120 4.724	83 3.268	240 9.449	67 2.638	45 1.772	P.69
<b>FT-Z40HBW</b>	1,300 51.181	290 11.417	210 8.268	220 8.661	57 2.244	33 1.299	110 4.331	32 1.260	19 0.748	P.69
<b>FT-Z40W</b>	2,200 86.614	460 18.110	340 13.386	380 14.961	90 3.543	63 2.480	170 6.693	45 1.772	30 1.181	P.69
<b>FT-Z802Y</b>	3,500 137.795 (Note 2)	750 29.528	540 21.260	450 17.717	110 4.331	80 3.150	300 11.811	80 3.150	60 2.362	P.69

Notes: 1) Note that the sensing range of the free-cut type fiber may be reduced by 20 % max. depending upon how the fiber is cut.  
 2) The fiber cable length practically limits the sensing range.

**Retroreflective type**



Fibers are listed in alphabetic order. Refer to “Fiber Selection p.5~” for details of each fiber.

Model No.	Sensing range (mm in) (Note 1,2)									Dimensions
	Red LED			Blue LED			Green LED			
	U-LG	STD	FAST	U-LG	STD	FAST	U-LG	STD	FAST	
<b>FR-KZ22E</b>	15 to 350 0.591 to 13.780	15 to 140 0.591 to 5.512	15 to 100 0.591 to 3.937	20 to 100 0.787 to 3.937	—	—	—	—	—	P.70
<b>FR-KZ50E</b>	20 to 400 0.787 to 15.748	20 to 200 0.787 to 7.874	20 to 200 0.787 to 7.874	20 to 200 0.787 to 7.874	20 to 84 0.787 to 3.307	20 to 45 0.787 to 1.771	20 to 180 0.787 to 7.087	20 to 55 0.787 to 1.969	—	P.70
<b>FR-KZ50H</b>	20 to 400 0.787 to 15.748	20 to 200 0.787 to 7.874	20 to 200 0.787 to 7.874	20 to 145 0.787 to 5.709	20 to 47 0.787 to 1.850	20 to 26 0.787 to 1.024	20 to 145 0.787 to 5.709	20 to 47 0.787 to 1.850	20 to 26 0.787 to 1.024	P.70
<b>FR-Z50HW</b>	100 to 1,000 3.937 to 39.370	100 to 540 3.937 to 21.260	100 to 460 3.937 to 18.110	100 to 490 3.937 to 19.291	—	—	—	—	—	P.70

Notes: 1) Note that the sensing range of the free-cut type fiber may be reduced by 20 % max. depending upon how the fiber is cut.  
 The sensing range of **FR-KZ22E** is specified for the attached reflector. The sensing range of **FR-KZ50E** and **FR-KZ50H** is specified for the attached reflector **RF-003**. The sensing range of **FR-Z50HW** is specified for the reflective tape **RF-13**.  
 2) The sensing range is the possible setting range for the attached reflector. The fiber can detect an object less than setting range for the reflector. However, note that if there are any white or highly-reflective surfaces near the fiber head, reflected incident light may affect the fiber head. If this occurs, adjust the threshold value of the amplifier unit before use.

**Sensing range when using in combination with FR-Z50HW reflector (Optional)**

The sensing ranges are the value for red LED types.

Reflector Model No.	Sensing range (mm in)		
	FX-411		
	U-LG	STD	FAST
<b>RF-230</b>	100 to 12,000 3.937 to 47.244	100 to 1,700 3.937 to 66.929	100 to 1,300 3.937 to 51.181
<b>RF-220</b>	100 to 2,200 3.937 to 8.661	100 to 950 3.937 to 37.402	100 to 730 3.937 to 28.740
<b>RF-210</b>	100 to 2,100 3.937 to 82.677	100 to 780 3.937 to 30.709	100 to 620 3.937 to 24.409

Note: The sensing range is the possible setting range for the reflector. The fiber can detect an object less than setting range for the reflector. However, note that if there are any white or highly-reflective surfaces near the fiber head, reflected incident light may affect the fiber head. If this occurs, adjust the threshold value of the amplifier unit before use.

FIBER SENSORS

LASER SENSORS

PHOTO-ELECTRIC SENSORS

MICRO PHOTO-ELECTRIC SENSORS

AREA SENSORS

SAFETY LIGHT CURTAINS / SAFETY COMPONENTS

PRESSURE / FLOW SENSORS

INDUCTIVE PROXIMITY SENSORS

PARTICULAR USE SENSORS

SENSOR OPTIONS

SMALL WIRE-SAVING UNITS

WIRE-SAVING SYSTEMS

MEASUREMENT SENSORS

STATIC CONTROL DEVICES

LASER MARKERS

PLC

HUMAN MACHINE INTERFACES

ENERGY MANAGEMENT SOLUTIONS

FA COMPONENTS

MACHINE VISION SYSTEMS

UV CURING SYSTEMS

Selection Guide

Fibers

Fiber Amplifiers

Other Products

**FX-500**

**FX-550**

**FX-100**

**FX-410**

**LIST OF FIBERS**

**Reflective type**



Fibers are listed in alphabetic order. Refer to "Fiber Selection p.5~" for details of each fiber.

Model No.	Sensing range (mm in) (Note 1, 2) / Description										Dimensions								
	Red LED			Blue LED			Green LED												
	U-LG	STD	FAST	U-LG	STD	FAST	U-LG	STD	FAST										
<b>FD-30</b>	200	7.874	48	1.890	35	1.378	40	1.575	9	0.354	6	0.236	18	0.709	5	0.197	3	0.118	P.71
<b>FD-31</b>	175	6.890	45	1.772	34	1.339	35	1.378	8	0.315	5	0.197	16	0.630	4	0.157	2	0.079	P.71
<b>FD-31W</b>	120	4.724	20	0.787	15	0.591	16	0.630	3	0.118	1 to 2.5	0.039 to 0.098	7	0.276	1 to 2.5	0.039 to 0.098	—	—	P.71
<b>FD-32G</b>	240	9.449	52	2.047	38	1.496	48	1.890	11	0.433	8	0.315	24	0.945	5	0.197	4	0.157	P.71
<b>FD-32GX</b>	320	12.598	50	1.969	38	1.496	50	1.969	12	0.472	9	0.354	24	0.945	7	0.276	4	0.157	P.71
<b>FD-34G</b>	150	5.906	30	1.181	22	0.866	19	0.748	5	0.197	0.2 to 3	0.008 to 0.118	10	0.394	0.3 to 2.5	0.012 to 0.098	0.4 to 1.5	0.016 to 0.059	P.71
<b>FD-40</b>	200	7.874	48	1.890	35	1.378	40	1.575	9	0.354	6	0.236	18	0.709	5	0.197	3	0.118	P.71
<b>FD-41</b>	175	6.890	45	1.772	34	1.339	35	1.378	8	0.315	5	0.197	16	0.630	4	0.157	2	0.079	P.71
<b>FD-41S</b>	175	6.890	40	1.575	30	1.181	35	1.378	8	0.315	5	0.197	16	0.630	4	0.157	2	0.079	P.71
<b>FD-41SW</b>	120	4.724	20	0.787	15	0.591	18	0.709	1 to 4	0.039 to 0.157	1 to 2.5	0.039 to 0.098	12	0.472	1 to 2.5	0.039 to 0.098	—	—	P.71
<b>FD-41W</b>	330	12.992	70	2.756	50	1.969	54	2.126	0.5 to 13	0.020 to 0.512	1 to 8	0.039 to 0.315	29	1.142	1.5 to 7	0.059 to 0.276	1.5 to 4.5	0.059 to 0.177	P.72
<b>FD-42G</b>	240	9.449	52	2.047	38	1.496	48	1.890	11	0.433	8	0.315	24	0.945	5	0.197	4	0.157	P.72
<b>FD-42GW</b>	240	9.449	40	1.575	30	1.181	30	1.181	7	0.276	5	0.197	15	0.591	4	0.157	2	0.079	P.72
<b>FD-60</b>	600	23.622	150	5.906	100	3.937	130	5.118	30	1.181	20	0.787	70	2.756	20	0.787	13	0.512	P.72
<b>FD-61</b>	510	20.079	140	5.512	90	3.543	105	4.134	27	1.063	18	0.709	65	2.559	16	0.630	11	0.433	P.72
<b>FD-61G</b>	460	18.110	110	4.331	80	3.150	105	4.134	27	1.063	18	0.709	55	2.165	15	0.591	9	0.354	P.72
<b>FD-61S</b>	500	19.685	140	5.512	95	3.740	105	4.134	27	1.063	18	0.709	65	2.559	16	0.630	11	0.433	P.72
<b>FD-61W</b>	330	12.992	70	2.756	50	1.969	54	2.126	0.5 to 13	0.020 to 0.512	1 to 8	0.039 to 0.315	29	1.142	1.5 to 7	0.059 to 0.276	1.5 to 4.5	0.059 to 0.177	P.73
<b>FD-62</b>	820	32.283	180	7.087	130	5.118	160	6.299	1 to 44	0.039 to 1.732	1 to 29	0.039 to 1.142	98	3.858	1 to 26	0.039 to 1.024	1 to 18	0.039 to 0.709	P.73
<b>FD-64X</b>	380	14.961	80	3.150	55	2.165	54	2.126	0.5 to 14	0.020 to 0.551	0.5 to 9	0.020 to 0.354	27	1.063	0.5 to 7	0.020 to 0.276	0.5 to 4.5	0.020 to 0.177	P.73
<b>FD-A16</b>	200	7.874	100	3.937	75	2.953	30	1.181	13	0.512	13	0.512	57	2.244	14	0.551	—	—	P.73
<b>FD-AL11</b>	460	18.110	100	3.937	70	2.756	70	2.756	17	0.669	10	0.394	45	1.772	9	0.354	6	0.236	P.73
<b>FD-E13</b>	20	0.787	4	0.157	3	0.118	2.5	0.098	0.7	0.028	—	—	1.5	0.059	—	—	—	—	P.73
<b>FD-E23</b>	75	2.953	15	0.591	10	0.394	10	0.394	2.5	0.098	1.5	0.059	5	0.197	1.3	0.051	0.9	0.035	P.73
<b>FD-EG30</b>	90	3.543	15	0.591	10	0.394	10	0.394	2.5	0.098	1.5	0.059	5	0.197	1.3	0.051	0.9	0.035	P.73
<b>FD-EG30S</b>	85	3.346	15	0.591	10	0.394	10	0.394	2.5	0.098	1.5	0.059	5	0.197	1.3	0.051	0.9	0.035	P.74
<b>FD-EG31</b>	25	0.984	5	0.197	4	0.157	4	0.157	1	0.039	0.5	0.020	2	0.079	—	—	—	—	P.74
<b>FD-F4</b>	Applicable pipe diameter: Outer dia. $\phi 6$ to $\phi 26$ mm $\phi 0.236$ to $\phi 1.024$ in transparent pipe [PFA (fluorine resin) or equivalently transparent pipe, wall thickness 1 mm 0.039 in] Liquid absent: Beam received, Liquid present: Beam not received										P.74								
<b>FD-F41</b>	Applicable pipe diameter: Outer dia. $\phi 6$ to $\phi 26$ mm $\phi 0.236$ to $\phi 1.024$ in transparent pipe [PVC (vinyl chloride), fluorine resin, polycarbonate, acrylic, glass, wall thickness 1 to 3 mm 0.039 to 0.118 in] Liquid absent: Beam received, Liquid present: Beam not received										P.74								
<b>FD-F41Y</b>	$\phi 4$ mm $\phi 0.157$ in Protective tube: Fluorine resin, length 500 mm 19.685 in (cuttable) Liquid surface not contacted: Beam received, Liquid surface contacted: Beam not received										P.74								
<b>FD-F8Y</b>	—	—	—	—	—	—	—	—	—	—	—	—	—	—	—	—	—	—	P.74
<b>FD-FA93</b>	Applicable pipe diameter: Outer dia. $\phi 8$ mm $\phi 0.315$ in or more transparent pipe (When used with the tying bands: $\phi 8$ to $\phi 80$ mm $\phi 0.315$ to $\phi 3.150$ in) [PFA (fluorine resin), including translucent] Liquid absent: Beam received, Liquid present: Beam not received										P.74								
<b>FD-H13-FM2</b>	430	16.929	100	3.937	70	2.756	40	1.575	10	0.394	7	0.276	40	1.575	10	0.394	7	0.276	P.75
<b>FD-H18-L31</b>	0 to 25	0 to 0.984	0 to 10	0 to 0.394	0 to 8	0 to 0.315	—	—	—	—	—	—	—	—	—	—	—	—	P.75
<b>FD-H20-21</b>	350	13.780	90	3.543	65	2.559	65	2.559	13	0.512	9	0.354	45	1.772	10	0.394	7	0.276	P.75
<b>FD-H20-M1</b>	270	10.630	85	3.346	60	2.362	60	2.362	14	0.551	10	0.394	58	2.283	10	0.394	7	0.276	P.75
<b>FD-H25-L43</b>	2.5 to 29	0.098 to 1.142	4 to 20	0.157 to 0.787	4 to 16	0.157 to 0.630	—	—	—	—	—	—	—	—	—	—	—	—	P.75
<b>FD-H25-L45</b>	5 to 42	0.197 to 1.654	7 to 38	0.276 to 1.496	7 to 35	0.276 to 1.437	—	—	—	—	—	—	—	—	—	—	—	—	P.75

Notes: 1) The standard sensing objects of the sensing ranges vary depending on the fibers.  
2) Note that the sensing range of the free-cut type fiber may be reduced by 20 % max. depending upon how the fiber is cut.

**LIST OF FIBERS**

**Reflective type**

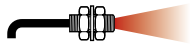

Fibers are listed in alphabetic order. Refer to "Fiber Selection p.5~" for details of each fiber.

Model No.	Sensing range (mm in) (Note 1, 2) / Description									Dimensions
	Red LED			Blue LED			Green LED			
	U-LG	STD	FAST	U-LG	STD	FAST	U-LG	STD	FAST	
<b>FD-H30-KZ1V-S</b> (Note 3)	20 to 300 0.787 to 11.811	25 to 100 0.984 to 3.937	25 to 45 0.984 to 1.772	—	—	—	—	—	—	P.76
<b>FD-H30-L32</b>	0 to 20 0 to 0.787	1 to 8 0.039 to 0.315	1 to 6 0.039 to 0.236	—	—	—	—	—	—	P.76
<b>FD-H30-L32V-S</b> (Note 3)	0 to 11 0 to 0.433	1.5 to 5 0.059 to 0.197	2 to 4 0.079 to 0.157	—	—	—	—	—	—	P.76
<b>FD-H35-20S</b>	210 8.268	50 1.969	35 1.378	45 1.772	10 0.394	7 0.276	20 0.787	6 0.236	4 0.157	P.76
<b>FD-H35-M2</b>	300 11.811	83 3.268	60 2.362	50 1.969	12 0.472	9 0.354	50 1.969	10 0.394	7 0.276	P.76
<b>FD-H35-M2S6</b>	300 11.811	80 3.150	50 1.969	50 1.969	14 0.551	10 0.394	40 1.575	10 0.394	7 0.276	P.76
<b>FD-HF40Y</b>	ø4 mm ø0.157 in Protective tube: fluorine resin, length:500 mm 19.685 in (allowable cutting) Liquid surface not contacted: Beam received, Liquid surface contacted: Beam not received									P.76
<b>FD-L10</b>	0 to 4.4 0 to 0.173	0 to 4 0 to 0.157	0 to 3.8 0 to 0.150	3.5 0.138	2.5 0.098	2 0.079	0 to 3 0 to 0.118	1 to 2 0.039 to 0.079	—	P.77
<b>FD-L11</b>	0 to 10 0 to 0.394	0 to 7 0 to 0.276	0 to 7 0 to 0.276	8.5 0.335	6 0.236	5.5 0.217	8 0.315	5 0.197	—	P.77
<b>FD-L12W</b>	0.5 to 10 0.020 to 0.394	1 to 4.5 0.039 to 0.177	1 to 3.5 0.039 to 0.137	—	—	—	—	—	—	P.77
<b>FD-L20H</b>	1 to 32 0.039 to 1.260	4 to 10 0.157 to 0.394	4.5 to 10 0.177 to 0.394	4 to 13 0.157 to 0.512	5 to 9 0.197 to 0.354	5.5 to 8.5 0.217 to 0.334	5 to 11 0.197 to 0.433	6 to 8.5 0.236 to 0.335	—	P.77
<b>FD-L21</b>	1 to 18 0.039 to 0.709	3 to 14 0.118 to 0.551	3 to 13 0.118 to 0.512	—	—	—	—	—	—	P.77
<b>FD-L21W</b>	3 to 16 0.118 to 0.630	7 to 12 0.276 to 0.472	7 to 11 0.276 to 0.433	—	—	—	—	—	—	P.77
<b>FD-L22A</b>	0 to 26 0 to 1.024	0 to 23 0 to 0.906	0 to 19 0 to 0.748	—	—	—	—	—	—	P.77
<b>FD-L23</b>	0 to 30 0 to 1.181	0 to 30 0 to 1.181	0 to 28 0 to 1.102	—	—	—	—	—	—	P.77
<b>FD-L30A</b>	0 to 50 0 to 1.969	0 to 36 0 to 1.417	0 to 30 0 to 1.181	—	—	—	—	—	—	P.77
<b>FD-L31A</b>	4 to 33 0.157 to 1.299	5 to 32 0.197 to 1.260	5 to 30 0.197 to 1.181	4 to 31 0.157 to 1.220	—	—	—	—	—	P.77
<b>FD-L32H</b>	0 to 65 0 to 2.559	15 to 30 0.591 to 1.181	20 to 25 0.787 to 0.984	15 to 30 0.591 to 1.181	—	—	—	—	—	P.78
<b>FD-R31G</b>	240 9.449	42 1.654	30 1.181	41 1.614	9 0.354	6 0.236	21 0.827	5 0.197	2 0.079	P.78
<b>FD-R32EG</b>	90 3.543	15 0.591	10 0.394	10 0.394	2.5 0.098	1.5 0.059	5 0.197	1.3 0.051	—	P.78
<b>FD-R33EG</b>	25 0.984	5 0.197	3 0.118	4 0.157	0.8 0.031	—	2 0.079	—	—	P.78
<b>FD-R34EG</b>	75 2.953	13 0.512	8 0.315	9 0.354	2 0.079	1 0.039	5 0.197	0.9 0.035	—	P.78
<b>FD-R41</b>	330 12.992	65 2.559	47 1.850	51 2.008	10 0.394	1 to 8 0.039 to 0.315	25 0.984	1 to 6 0.039 to 0.236	1 to 5 0.039 to 0.197	P.78
<b>FD-R60</b>	420 16.535	110 4.331	80 3.150	82 3.228	23 0.906	15 0.591	59 2.323	15 0.591	10 0.394	P.78
<b>FD-R61Y</b>	340 13.386	65 2.559	47 1.850	60 2.362	0.5 to 15 0.020 to 0.591	0.5 to 10 0.020 to 0.394	30 1.181	0.5 to 7 0.020 to 0.276	1 to 5 0.039 to 0.197	P.78
<b>FD-S21</b>	80 3.150	18 0.709	13 0.512	12 0.472	2.5 0.098	2 0.079	6.5 0.256	1.5 0.059	1 0.039	P.78
<b>FD-S30</b>	200 7.874	48 0.890	35 1.378	40 1.575	9 0.354	6 0.236	18 0.709	5 0.197	3 0.118	P.79
<b>FD-S31</b>	175 6.890	45 1.772	34 1.339	35 1.378	8 0.315	5 0.197	16 0.630	4 0.157	2 0.079	P.79
<b>FD-S32</b>	510 20.079	120 4.724	90 3.543	105 4.134	27 1.063	18 0.709	65 2.559	16 0.630	11 0.433	P.79
<b>FD-S32W</b>	330 12.992	70 2.756	50 1.969	54 2.126	0.5 to 13 0.020 to 0.512	1 to 8 0.039 to 0.315	29 1.142	1.5 to 7 0.059 to 0.276	1.5 to 4.5 0.059 to 0.177	P.79
<b>FD-S33GW</b>	240 9.449	40 1.575	30 1.181	30 1.181	7 0.276	5 0.197	15 0.591	4 0.157	2 0.079	P.79
<b>FD-S34G</b>	150 5.906	30 1.181	22 0.866	19 0.748	5 0.197	0.2 to 3 0.008 to 0.118	10 0.394	0.3 to 2.5 0.012 to 0.098	0.4 to 1.5 0.016 to 0.059	P.79
<b>FD-S60Y</b>	410 16.142	130 5.118	100 3.937	120 4.724	25 0.984	17 0.669	65 2.559	10 0.394	—	P.79
<b>FD-V30</b>	110 4.331	19 0.748	14 0.551	18 0.709	—	—	10 0.394	—	—	P.79
<b>FD-V30W</b>	30 1.181	5 0.197	3 0.118	—	—	—	—	—	—	P.80
<b>FD-V50</b>	160 6.299	35 1.378	25 0.984	27 1.063	7 0.276	—	16 0.630	—	—	P.80
<b>FD-Z20HBW</b>	1 to 100 0.039 to 3.937	3 to 20 0.118 to 0.787	3 to 15 0.118 to 0.591	3 to 16 0.118 to 0.630	—	—	3 to 8 0.118 to 0.315	—	—	P.80
<b>FD-Z20W</b>	140 5.512	3 to 26 0.118 to 1.024	3 to 17 0.118 to 0.669	4 to 12 0.157 to 0.472	—	—	—	—	—	P.80
<b>FD-Z40HBW</b>	420 16.535	1 to 80 0.039 to 3.150	1 to 60 0.039 to 2.362	1 to 89 0.039 to 3.504	3 to 20 1.181 to 0.787	3 to 13 1.181 to 0.512	1 to 42 0.039 to 1.654	3 to 11 0.118 to 0.433	3 to 7 0.118 to 0.276	P.80
<b>FD-Z40W</b>	340 13.386	1 to 67 0.039 to 2.638	1 to 48 0.039 to 1.890	1 to 55 0.039 to 2.165	5 to 10 0.197 to 0.394	—	3 to 25 0.118 to 0.394	—	—	P.80
<b>FD-Z50HW</b>	10 to 890 0.394 to 35.039	15 to 210 0.591 to 8.268	15 to 160 0.591 to 6.299	20 to 100 0.787 to 3.937	—	—	20 to 55 0.787 to 2.165	—	—	P.80

Notes: 1) The standard sensing objects of the sensing ranges vary depending on the fibers.  
 2) Note that the sensing range of the free-cut type fiber may be reduced by 20 % max. depending upon how the fiber is cut.  
 3) Sold as a set comprising vacuum type fiber + photo-terminal (FV-BR1) + fiber at atmospheric side (FT-J8). Please refer to p.39 for details.

FIBER SENSORS

LASER SENSORS

PHOTO-ELECTRIC SENSORS

MICRO PHOTO-ELECTRIC SENSORS

AREA SENSORS

SAFETY LIGHT CURTAINS / SAFETY COMPONENTS

PRESSURE / FLOW SENSORS

INDUCTIVE PROXIMITY SENSORS

PARTICULAR USE SENSORS

SENSOR OPTIONS

SIMPLE WIRE-SAVING UNITS

WIRE-SAVING SYSTEMS

MEASUREMENT SENSORS

STATIC CONTROL DEVICES

LASER MARKERS

PLC

HUMAN MACHINE INTERFACES

ENERGY MANAGEMENT SOLUTIONS

FA COMPONENTS

MACHINE VISION SYSTEMS

UV CURING SYSTEMS

Selection Guide

Fibers

Fiber Amplifiers

Other Products

FX-500

FX-550

FX-100

FX-410



**FIBER OPTIONS**

Refer to p.81~ for lens dimensions.

**Lens (For thru-beam type fiber)**

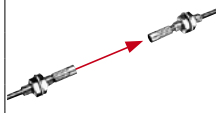
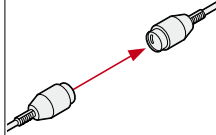
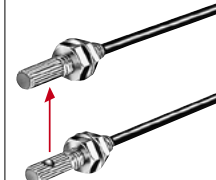
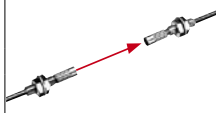
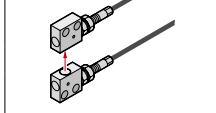
Designation	Model No.	Description																																																																				
Expansion lens (Note 1)	<b>FX-LE1</b>		<p>Increases the sensing range by 5 times or more.</p> <ul style="list-style-type: none"> <li>Ambient temperature: -60 to +350 °C -76 to +662 °F (Note 5)</li> <li>Beam dia: ø3.6 mm ø0.142 in</li> </ul>																																																																			
				<p><b>Sensing range for red LED type (mm in) [Lens on both sides] (Note 2)</b></p> <table border="1"> <thead> <tr> <th>Fiber</th> <th>Mode</th> <th>U-LG</th> <th>STD</th> <th>FAST</th> </tr> </thead> <tbody> <tr> <td><b>FT-43</b></td> <td>3,600</td> <td>141.732 (Note 3)</td> <td>2,300 90.551</td> <td>1,700 66.929</td> </tr> <tr> <td><b>FT-42</b></td> <td>3,600</td> <td>141.732 (Note 3)</td> <td>3,200 125.984</td> <td>2,300 90.551</td> </tr> <tr> <td><b>FT-42W</b></td> <td>3,600</td> <td>141.732 (Note 3)</td> <td>3,600 141.732 (Note 3)</td> <td>2,600 102.362</td> </tr> <tr> <td><b>FT-45X</b></td> <td>1,600</td> <td>62.992 (Note 3)</td> <td>1,600 62.992 (Note 3)</td> <td>1,600 62.992 (Note 3)</td> </tr> <tr> <td><b>FT-R40</b></td> <td>3,600</td> <td>141.732 (Note 3)</td> <td>2,900 114.173</td> <td>2,300 90.551</td> </tr> <tr> <td><b>FT-R43</b></td> <td>3,600</td> <td>141.732 (Note 3)</td> <td>2,600 102.362</td> <td>1,900 74.803</td> </tr> <tr> <td><b>FT-R44Y</b></td> <td>3,600</td> <td>141.732 (Note 3)</td> <td>2,600 102.362</td> <td>1,900 74.803</td> </tr> <tr> <td><b>FT-H35-M2</b></td> <td>3,500</td> <td>137.795 (Note 3)</td> <td>1,100 43.307</td> <td>800 31.496</td> </tr> <tr> <td><b>FT-H20W-M1</b></td> <td>1,600</td> <td>62.992 (Note 3)</td> <td>1,200 47.244</td> <td>800 31.496</td> </tr> <tr> <td><b>FT-H20-M1</b></td> <td>1,600</td> <td>62.992 (Note 3)</td> <td>800 31.496</td> <td>600 23.622</td> </tr> </tbody> </table>		Fiber	Mode	U-LG	STD	FAST	<b>FT-43</b>	3,600	141.732 (Note 3)	2,300 90.551	1,700 66.929	<b>FT-42</b>	3,600	141.732 (Note 3)	3,200 125.984	2,300 90.551	<b>FT-42W</b>	3,600	141.732 (Note 3)	3,600 141.732 (Note 3)	2,600 102.362	<b>FT-45X</b>	1,600	62.992 (Note 3)	1,600 62.992 (Note 3)	1,600 62.992 (Note 3)	<b>FT-R40</b>	3,600	141.732 (Note 3)	2,900 114.173	2,300 90.551	<b>FT-R43</b>	3,600	141.732 (Note 3)	2,600 102.362	1,900 74.803	<b>FT-R44Y</b>	3,600	141.732 (Note 3)	2,600 102.362	1,900 74.803	<b>FT-H35-M2</b>	3,500	137.795 (Note 3)	1,100 43.307	800 31.496	<b>FT-H20W-M1</b>	1,600	62.992 (Note 3)	1,200 47.244	800 31.496	<b>FT-H20-M1</b>	1,600	62.992 (Note 3)	800 31.496	600 23.622										
				Fiber	Mode	U-LG	STD	FAST																																																														
				<b>FT-43</b>	3,600	141.732 (Note 3)	2,300 90.551	1,700 66.929																																																														
<b>FT-42</b>	3,600	141.732 (Note 3)	3,200 125.984	2,300 90.551																																																																		
<b>FT-42W</b>	3,600	141.732 (Note 3)	3,600 141.732 (Note 3)	2,600 102.362																																																																		
<b>FT-45X</b>	1,600	62.992 (Note 3)	1,600 62.992 (Note 3)	1,600 62.992 (Note 3)																																																																		
<b>FT-R40</b>	3,600	141.732 (Note 3)	2,900 114.173	2,300 90.551																																																																		
<b>FT-R43</b>	3,600	141.732 (Note 3)	2,600 102.362	1,900 74.803																																																																		
<b>FT-R44Y</b>	3,600	141.732 (Note 3)	2,600 102.362	1,900 74.803																																																																		
<b>FT-H35-M2</b>	3,500	137.795 (Note 3)	1,100 43.307	800 31.496																																																																		
<b>FT-H20W-M1</b>	1,600	62.992 (Note 3)	1,200 47.244	800 31.496																																																																		
<b>FT-H20-M1</b>	1,600	62.992 (Note 3)	800 31.496	600 23.622																																																																		
Super-expansion lens (Note 1)	<b>FX-LE2</b>		<p>Tremendously increases the sensing range with large diameter lenses.</p> <ul style="list-style-type: none"> <li>Ambient temperature: -60 to +350 °C -76 to +662 °F (Note 5)</li> <li>Beam dia: ø9.8 mm ø0.386 in</li> </ul>																																																																			
				<p><b>Sensing range for red LED type (mm in) [Lens on both sides] (Note 2)</b></p> <table border="1"> <thead> <tr> <th>Fiber</th> <th>Mode</th> <th>U-LG</th> <th>STD</th> <th>FAST</th> </tr> </thead> <tbody> <tr> <td><b>FT-43</b></td> <td>3,600</td> <td>141.732 (Note 3)</td> <td>3,600 141.732 (Note 3)</td> <td>3,600 141.732 (Note 3)</td> </tr> <tr> <td><b>FT-42</b></td> <td>3,600</td> <td>141.732 (Note 3)</td> <td>3,600 141.732 (Note 3)</td> <td>3,600 141.732 (Note 3)</td> </tr> <tr> <td><b>FT-42W</b></td> <td>3,600</td> <td>141.732 (Note 3)</td> <td>3,600 141.732 (Note 3)</td> <td>3,600 141.732 (Note 3)</td> </tr> <tr> <td><b>FT-45X</b></td> <td>1,600</td> <td>62.992 (Note 3)</td> <td>1,600 62.992 (Note 3)</td> <td>1,600 62.992 (Note 3)</td> </tr> <tr> <td><b>FT-R40</b></td> <td>3,600</td> <td>141.732 (Note 3)</td> <td>3,600 141.732 (Note 3)</td> <td>3,600 141.732 (Note 3)</td> </tr> <tr> <td><b>FT-R41W</b></td> <td>3,600</td> <td>141.732 (Note 3)</td> <td>3,600 141.732 (Note 3)</td> <td>3,600 141.732 (Note 3)</td> </tr> <tr> <td><b>FT-R43</b></td> <td>3,600</td> <td>141.732 (Note 3)</td> <td>3,600 141.732 (Note 3)</td> <td>3,600 141.732 (Note 3)</td> </tr> <tr> <td><b>FT-R44Y</b></td> <td>3,600</td> <td>141.732 (Note 3)</td> <td>3,600 141.732 (Note 3)</td> <td>3,600 141.732 (Note 3)</td> </tr> <tr> <td><b>FT-H35-M2</b></td> <td>3,500</td> <td>137.795 (Note 3)</td> <td>3,500 137.795 (Note 3)</td> <td>3,500 137.795 (Note 3)</td> </tr> <tr> <td><b>FT-H20W-M1</b></td> <td>1,600</td> <td>62.992 (Note 3)</td> <td>1,600 62.992 (Note 3)</td> <td>1,600 62.992 (Note 3)</td> </tr> <tr> <td><b>FT-H20-M1</b></td> <td>1,600</td> <td>62.992 (Note 3)</td> <td>1,600 62.992 (Note 3)</td> <td>1,600 62.992 (Note 3)</td> </tr> <tr> <td><b>FT-H13-FM2</b></td> <td>3,500</td> <td>137.795 (Note 3)</td> <td>3,500 137.795 (Note 3)</td> <td>3,500 137.795 (Note 3)</td> </tr> </tbody> </table>		Fiber	Mode	U-LG	STD	FAST	<b>FT-43</b>	3,600	141.732 (Note 3)	3,600 141.732 (Note 3)	3,600 141.732 (Note 3)	<b>FT-42</b>	3,600	141.732 (Note 3)	3,600 141.732 (Note 3)	3,600 141.732 (Note 3)	<b>FT-42W</b>	3,600	141.732 (Note 3)	3,600 141.732 (Note 3)	3,600 141.732 (Note 3)	<b>FT-45X</b>	1,600	62.992 (Note 3)	1,600 62.992 (Note 3)	1,600 62.992 (Note 3)	<b>FT-R40</b>	3,600	141.732 (Note 3)	3,600 141.732 (Note 3)	3,600 141.732 (Note 3)	<b>FT-R41W</b>	3,600	141.732 (Note 3)	3,600 141.732 (Note 3)	3,600 141.732 (Note 3)	<b>FT-R43</b>	3,600	141.732 (Note 3)	3,600 141.732 (Note 3)	3,600 141.732 (Note 3)	<b>FT-R44Y</b>	3,600	141.732 (Note 3)	3,600 141.732 (Note 3)	3,600 141.732 (Note 3)	<b>FT-H35-M2</b>	3,500	137.795 (Note 3)	3,500 137.795 (Note 3)	3,500 137.795 (Note 3)	<b>FT-H20W-M1</b>	1,600	62.992 (Note 3)	1,600 62.992 (Note 3)	1,600 62.992 (Note 3)	<b>FT-H20-M1</b>	1,600	62.992 (Note 3)	1,600 62.992 (Note 3)	1,600 62.992 (Note 3)	<b>FT-H13-FM2</b>	3,500	137.795 (Note 3)	3,500 137.795 (Note 3)	3,500 137.795 (Note 3)
				Fiber	Mode	U-LG	STD	FAST																																																														
				<b>FT-43</b>	3,600	141.732 (Note 3)	3,600 141.732 (Note 3)	3,600 141.732 (Note 3)																																																														
<b>FT-42</b>	3,600	141.732 (Note 3)	3,600 141.732 (Note 3)	3,600 141.732 (Note 3)																																																																		
<b>FT-42W</b>	3,600	141.732 (Note 3)	3,600 141.732 (Note 3)	3,600 141.732 (Note 3)																																																																		
<b>FT-45X</b>	1,600	62.992 (Note 3)	1,600 62.992 (Note 3)	1,600 62.992 (Note 3)																																																																		
<b>FT-R40</b>	3,600	141.732 (Note 3)	3,600 141.732 (Note 3)	3,600 141.732 (Note 3)																																																																		
<b>FT-R41W</b>	3,600	141.732 (Note 3)	3,600 141.732 (Note 3)	3,600 141.732 (Note 3)																																																																		
<b>FT-R43</b>	3,600	141.732 (Note 3)	3,600 141.732 (Note 3)	3,600 141.732 (Note 3)																																																																		
<b>FT-R44Y</b>	3,600	141.732 (Note 3)	3,600 141.732 (Note 3)	3,600 141.732 (Note 3)																																																																		
<b>FT-H35-M2</b>	3,500	137.795 (Note 3)	3,500 137.795 (Note 3)	3,500 137.795 (Note 3)																																																																		
<b>FT-H20W-M1</b>	1,600	62.992 (Note 3)	1,600 62.992 (Note 3)	1,600 62.992 (Note 3)																																																																		
<b>FT-H20-M1</b>	1,600	62.992 (Note 3)	1,600 62.992 (Note 3)	1,600 62.992 (Note 3)																																																																		
<b>FT-H13-FM2</b>	3,500	137.795 (Note 3)	3,500 137.795 (Note 3)	3,500 137.795 (Note 3)																																																																		
Side-view lens	<b>FX-SV1</b>		<p>Beam axis is bent by 90°.</p> <ul style="list-style-type: none"> <li>Ambient temperature: -60 to +300 °C -76 to +572 °F (Note 5)</li> <li>Beam dia: ø2.8 mm ø0.110 in</li> </ul>																																																																			
				<p><b>Sensing range for red LED type (mm in) [Lens on both sides] (Note 2)</b></p> <table border="1"> <thead> <tr> <th>Fiber</th> <th>Mode</th> <th>U-LG</th> <th>STD</th> <th>FAST</th> </tr> </thead> <tbody> <tr> <td><b>FT-43</b></td> <td>2,300</td> <td>90.551</td> <td>480 18.898</td> <td>350 13.780</td> </tr> <tr> <td><b>FT-42</b></td> <td>2,400</td> <td>94.488</td> <td>450 17.717</td> <td>330 12.992</td> </tr> <tr> <td><b>FT-42W</b></td> <td>2,800</td> <td>110.236</td> <td>600 23.622</td> <td>450 17.717</td> </tr> <tr> <td><b>FT-45X</b></td> <td>1,600</td> <td>62.992 (Note 3)</td> <td>530 20.866</td> <td>370 14.567</td> </tr> <tr> <td><b>FT-R43</b></td> <td>2,300</td> <td>90.551</td> <td>430 16.929</td> <td>320 12.598</td> </tr> <tr> <td><b>FT-R44Y</b></td> <td>2,300</td> <td>90.551</td> <td>430 16.929</td> <td>320 12.598</td> </tr> <tr> <td><b>FT-H35-M2</b></td> <td>870</td> <td>34.252</td> <td>220 8.661</td> <td>160 6.299</td> </tr> <tr> <td><b>FT-H20W-M1</b></td> <td>750</td> <td>29.528</td> <td>200 7.874</td> <td>140 5.512</td> </tr> <tr> <td><b>FT-H20-M1</b></td> <td>870</td> <td>34.252</td> <td>220 8.661</td> <td>160 6.299</td> </tr> </tbody> </table>		Fiber	Mode	U-LG	STD	FAST	<b>FT-43</b>	2,300	90.551	480 18.898	350 13.780	<b>FT-42</b>	2,400	94.488	450 17.717	330 12.992	<b>FT-42W</b>	2,800	110.236	600 23.622	450 17.717	<b>FT-45X</b>	1,600	62.992 (Note 3)	530 20.866	370 14.567	<b>FT-R43</b>	2,300	90.551	430 16.929	320 12.598	<b>FT-R44Y</b>	2,300	90.551	430 16.929	320 12.598	<b>FT-H35-M2</b>	870	34.252	220 8.661	160 6.299	<b>FT-H20W-M1</b>	750	29.528	200 7.874	140 5.512	<b>FT-H20-M1</b>	870	34.252	220 8.661	160 6.299															
				Fiber	Mode	U-LG	STD	FAST																																																														
				<b>FT-43</b>	2,300	90.551	480 18.898	350 13.780																																																														
<b>FT-42</b>	2,400	94.488	450 17.717	330 12.992																																																																		
<b>FT-42W</b>	2,800	110.236	600 23.622	450 17.717																																																																		
<b>FT-45X</b>	1,600	62.992 (Note 3)	530 20.866	370 14.567																																																																		
<b>FT-R43</b>	2,300	90.551	430 16.929	320 12.598																																																																		
<b>FT-R44Y</b>	2,300	90.551	430 16.929	320 12.598																																																																		
<b>FT-H35-M2</b>	870	34.252	220 8.661	160 6.299																																																																		
<b>FT-H20W-M1</b>	750	29.528	200 7.874	140 5.512																																																																		
<b>FT-H20-M1</b>	870	34.252	220 8.661	160 6.299																																																																		
Expansion lens for vacuum fiber (Note 1)	<b>FV-LE1</b>		<p>Sensing range increases by 4 times or more.</p> <ul style="list-style-type: none"> <li>Ambient temperature: -60 to +350 °C -76 to +662 °F (Note 5)</li> <li>Beam dia: ø3.6 mm ø0.142 in</li> </ul>																																																																			
				<p><b>Sensing range for red LED type (mm in) [Lens on both sides] (Note 2, 4)</b></p> <table border="1"> <thead> <tr> <th>Fiber</th> <th>Mode</th> <th>U-LG</th> <th>STD</th> <th>FAST</th> </tr> </thead> <tbody> <tr> <td><b>FT-H30-M1V-S</b></td> <td>1,600</td> <td>62.992</td> <td>450 17.717</td> <td>300 11.811</td> </tr> </tbody> </table>		Fiber	Mode	U-LG	STD	FAST	<b>FT-H30-M1V-S</b>	1,600	62.992	450 17.717	300 11.811																																																							
Fiber	Mode	U-LG	STD	FAST																																																																		
<b>FT-H30-M1V-S</b>	1,600	62.992	450 17.717	300 11.811																																																																		
Vacuum resistant side-view lens (Note 1)	<b>FV-SV2</b>		<p>Beam axis is bent by 90°.</p> <ul style="list-style-type: none"> <li>Ambient temperature: -60 to +300 °C -76 to +572 °F (Note 5)</li> <li>Beam dia: ø3.7 mm ø0.146 in</li> </ul>																																																																			
			<p><b>Sensing range for red LED type (mm in) [Lens on both sides] (Note 2, 4)</b></p> <table border="1"> <thead> <tr> <th>Fiber</th> <th>Mode</th> <th>U-LG</th> <th>STD</th> <th>FAST</th> </tr> </thead> <tbody> <tr> <td><b>FT-H30-M1V-S</b></td> <td>1,600</td> <td>62.992</td> <td>450 17.717</td> <td>300 11.811</td> </tr> </tbody> </table>	Fiber	Mode	U-LG	STD	FAST	<b>FT-H30-M1V-S</b>	1,600	62.992	450 17.717	300 11.811																																																									
Fiber	Mode	U-LG	STD	FAST																																																																		
<b>FT-H30-M1V-S</b>	1,600	62.992	450 17.717	300 11.811																																																																		



- Notes: 1) Be careful sure to use it only after you have adjusted it sufficiently when installing the thru-beam type fiber equipped with the expansion lens, as the beam envelope becomes narrow and alignment is difficult.  
 2) The sensing ranges are the values for red LED type amplifier. Please contact our office for details on sensing ranges for other types of amplifiers.  
 3) The fiber cable length practically limits the sensing range.  
 4) The fiber cable length for the **FT-H30-M1V-S** is 1 m 3.281 ft. The sensing ranges in U-LG mode take into account the length of the **FT-J8** atmospheric side fiber.  
 5) Refer to "Fiber Selection p.5~" for the ambient temperatures of fibers to be used in combination.

FIBER SENSORS  
 LASER SENSORS  
 PHOTO-ELECTRIC SENSORS  
 MICRO PHOTO-ELECTRIC SENSORS  
 AREA SENSORS  
 SAFETY LIGHT CURTAINS / SAFETY COMPONENTS  
 PRESSURE / FLOW SENSORS  
 INDUCTIVE PROXIMITY SENSORS  
 PARTICULAR USE SENSORS  
 SENSOR OPTIONS  
 SIMPLE WIRE-SAVING UNITS  
 WIRE-SAVING SYSTEMS  
 MEASUREMENT SENSORS  
 STATIC CONTROL DEVICES  
 LASER MARKERS  
 PLC  
 HUMAN MACHINE INTERFACES  
 ENERGY MANAGEMENT SOLUTIONS  
 FA COMPONENTS  
 MACHINE VISION SYSTEMS  
 UV CURING SYSTEMS  
 Selection Guide  
 Fibers  
 Fiber Amplifiers  
 Other Products  
**FX-500**  
**FX-550**  
**FX-100**  
**FX-410**

**FIBER OPTIONS**

Refer to p.81~ for details of lens dimensions.

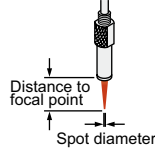
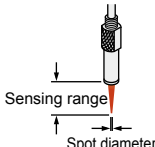
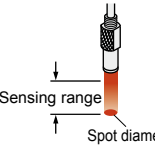
**Lens (For reflective type fiber)**

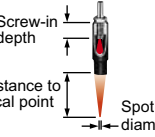
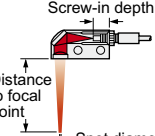
Designation	Model No.	Description	
Pinpoint spot lens	<b>FX-MR7</b>		Extremely fine spot of $\phi 0.1$ mm $\phi 0.004$ in approx. achieved. • Applicable fibers: <b>FD-R33EG, FD-EG31, FD-R34EG, FD-R32EG, FD-EG30, FD-R31G, FD-42G, FD-42GW, FD-32G, FD-32GX</b> • Ambient temperature: $-55$ to $+70$ °C $-67$ to $+158$ °F (Note 2)
	<b>FX-MR6</b>		Extremely fine spot of $\phi 0.1$ mm $\phi 0.004$ in approx. achieved. • Applicable fibers: <b>FD-EG31, FD-EG30, FD-42G, FD-42GW, FD-32G, FD-32GX</b> • Ambient temperature: $-20$ to $+60$ °C $-4$ to $+140$ °F (Note 2)
	<b>FX-MR3</b>		Extremely fine spot of $\phi 0.15$ mm $\phi 0.006$ in approx. achieved. • Applicable fibers: <b>FD-EG31, FD-EG30, FD-42G, FD-42GW, FD-32G, FD-32GX</b> • Ambient temperature: $-40$ to $+70$ °C $-40$ to $+158$ °F (Note 2)
Zoom lens	<b>FX-MR8</b>		The spot diameter is adjustable according to how much the fiber is screwed in. • Applicable fibers: <b>FD-R33EG, FD-EG31, FD-R34EG, FD-R32EG, FD-EG30, FD-R31G, FD-42G, FD-42GW, FD-32G, FD-32GX</b> • Ambient temperature: $-55$ to $+70$ °C $-67$ to $+158$ °F (Note 2)
Parallel light lens	<b>FX-MR9</b>		Long-range parallel light • Applicable fibers: <b>FD-R33EG, FD-EG31, FD-R34EG, FD-R32EG, FD-EG30, FD-R31G, FD-42G, FD-42GW, FD-32G, FD-32GX</b> • Ambient temperature: $-55$ to $+70$ °C $-67$ to $+158$ °F (Note 2)
Pinpoint spot lens	<b>FX-MR1</b>		Pinpoint spot of $\phi 0.5$ mm $\phi 0.020$ in. Enables detection of minute objects or small marks. • Distance to focal point: $6 \pm 1$ mm $0.236 \pm 0.039$ in • Applicable fibers: <b>FD-42G, FD-42GW</b> • Ambient temperature: $-40$ to $+70$ °C $-40$ to $+158$ °F (Note 2)
Zoom lens	<b>FX-MR2</b>		The spot diameter is adjustable from $\phi 0.7$ to $\phi 2$ mm $\phi 0.028$ to $\phi 0.079$ in according to how much the fiber is screwed in. • Applicable fibers: <b>FD-42G, FD-42GW</b> • Ambient temperature: $-40$ to $+70$ °C $-40$ to $+158$ °F (Note 1) • Accessory: <b>MS-EX3</b> (mounting bracket)
Zoom lens (Side-view type)	<b>FX-MR5</b>		<b>FX-MR2</b> is converted into a side-view type and can be mounted in a very small space. • Applicable fibers: <b>FD-42G, FD-42GW</b> • Ambient temperature: $-40$ to $+60$ °C $-40$ to $+140$ °F (Note 2)

Notes: 1) The sensing ranges are the values when used in combination with red LED type amplifier. Please contact our office for details on sensing ranges for other types of amplifier.  
 2) Refer to p.16, p.18, p.26 and p.27 for the ambient temperatures of fibers to be used in combination.

FIBER SENSORS

LASER SENSORS

PHOTO-ELECTRIC SENSORS

MICRO PHOTO-ELECTRIC SENSORS

AREA SENSORS

SAFETY LIGHT CURTAINS / SAFETY COMPONENTS

PRESSURE / FLOW SENSORS

INDUCTIVE PROXIMITY SENSORS

PARTICULAR USE SENSORS

SENSOR OPTIONS

SMALL WIRE-SAVING UNITS

WIRE-SAVING SYSTEMS

MEASUREMENT SENSORS

STATIC CONTROL DEVICES

LASER MARKERS

PLC

HUMAN MACHINE INTERFACES

ENERGY MANAGEMENT SOLUTIONS

FA COMPONENTS

MACHINE VISION SYSTEMS

UV CURING SYSTEMS

Selection Guide

Fibers

Fiber Amplifiers

Other Products

**FX-500**

**FX-550**

**FX-100**

**FX-410**

**FIBER OPTIONS**

Refer to p.81~ for details of lens dimensions.

FIBER SENSORS

LASER SENSORS

PHOTO-ELECTRIC SENSORS

MICRO PHOTO-ELECTRIC SENSORS

AREA SENSORS

SAFETY LIGHT CURTAINS / SAFETY COMPONENTS

PRESSURE / FLOW SENSORS

INDUCTIVE PROXIMITY SENSORS

PARTICULAR USE SENSORS

SENSOR OPTIONS

SIMPLE WIRE-SAVING UNITS

WIRE-SAVING SYSTEMS

MEASUREMENT SENSORS

STATIC CONTROL DEVICES

LASER MARKERS

PLC

HUMAN MACHINE INTERFACES

ENERGY MANAGEMENT SOLUTIONS

FA COMPONENTS

MACHINE VISION SYSTEMS

UV CURING SYSTEMS

Selection Guide

Fibers

Fiber Amplifiers

Other Products

**FX-500**

**FX-550**

**FX-100**

**FX-410**

**Model No. when ordering heat-resistant fibers individually as replacement parts**

- Heat-resistant side fiber  
**FT-H20-J20** (one pair set), **FT-H20-J30** (one pair set), **FT-H20-J50** (one pair set), **FT-H20-VJ50** (one pair set), **FT-H20-VJ80** (one pair set)
- Ordinary temperature side fiber  
**FT-42** (one pair set)

**Model No. when ordering vacuum-resistant fibers individually as replacement parts**

- Vacuum-resistant fiber  
**FT-H30-M1V** (one pair set)  
**FD-H30-KZ1V**  
**FD-H30-L32V**
- Photo-terminal  
**FV-BR1** (one pair set)
- Fiber at atmospheric side  
**FT-J8** (one pair set)

- Mounting bracket for **FD-H30-KZ1V(-S)**  
**MS-FD-2**

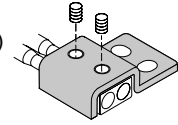

**Model No. when ordering accessories additionally**

- **RF-003** (Reflector for **FR-KZ50E/KZ50H**)
- **RF-13** (Reflective tape for **FR-Z50HW**)
- **FX-CT2** (Fiber cutter)
- **FX-CT3** (Fiber cutter for  $\phi 1$  mm  $\phi 0.039$  in /  $\phi 1.3$  mm  $\phi 0.051$  in fiber cable /  $\phi 4$  mm  $\phi 0.157$  in protective tube)
- **FX-CT4** (Fiber cutter for  $\phi 2$  mm  $\phi 0.079$  in fiber cable /  $\phi 4$  mm  $\phi 0.157$  in protective tube)
- **FX-AT2** (Attachment for fixed-length fiber, Orange)
- **FX-AT3** (Attachment for  $\phi 2.2$  mm  $\phi 0.087$  in fiber, Clear orange)
- **FX-AT4** (Attachment for  $\phi 1$  mm  $\phi 0.039$  in fiber, Black)
- **FX-AT5** (Attachment for  $\phi 1.3$  mm  $\phi 0.051$  in fiber, Gray)
- **FX-AT6** (Attachment for  $\phi 1$  mm  $\phi 0.039$  in /  $\phi 1.3$  mm  $\phi 0.051$  in mixed fiber, Black / Gray)
- **FX-AT4G1** (Gland single for  $\phi 1$  mm  $\phi 0.039$  in fiber, Black)
- **FX-AT5G1** (Gland single for  $\phi 1.3$  mm  $\phi 0.051$  in fiber, Gray)
- **FX-AT6G1** (Gland single for  $\phi 1$  mm  $\phi 0.039$  in /  $\phi 1.3$  mm  $\phi 0.051$  in mixed fiber, Black / Gray)
- **FX-SL1** (one pair set) Slit mask for **FT-A11 / FT-A11W**, slit size:  $0.5 \times 12$  mm  $0.020 \times 0.472$  in
- **FX-SL2** (one pair set) Slit mask for **FT-A11 / FT-A11W**, slit size:  $1 \times 12$  mm  $0.039 \times 0.472$  in
- **FX-SL3** (one pair set) Slit mask for **FT-A11 / FT-A11W**, slit size:  $0.5 \times 33$  mm  $0.020 \times 1.299$  in
- **MS-FD-2** (Fiber mounting bracket)

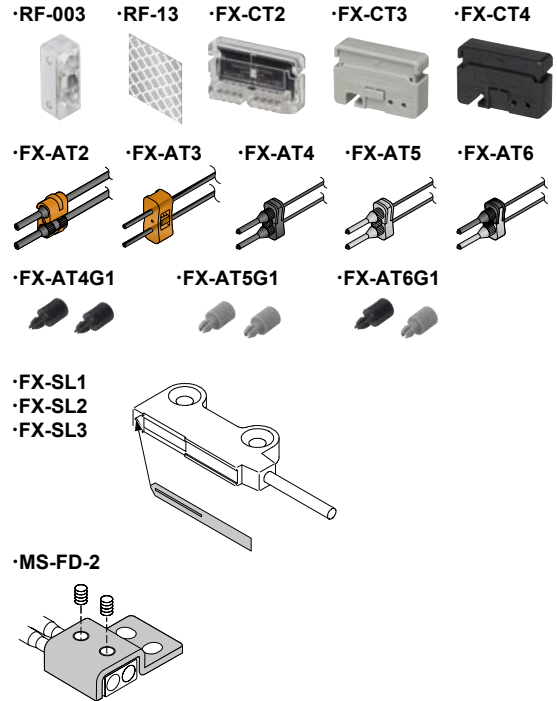

**Others**

Designation	Model No.	Description	
Protective tube (For thru-beam type fiber)	<b>FTP-500</b> (0.5 m 1.641 ft)	For M4 thread	The protective tube, made of noncorrosive stainless steel, protects the inner fiber cable from any external forces.
	<b>FTP-1000</b> (1 m 3.281 ft)		
	<b>FTP-1500</b> (1.5 m 4.922 ft)		
	<b>FTP-N500</b> (0.5 m 1.641 ft)	For M3 thread	
	<b>FTP-N1000</b> (1 m 3.281 ft)		
	<b>FTP-N1500</b> (1.5 m 4.922 ft)		
Protective tube (For reflective type fiber)	<b>FDP-500</b> (0.5 m 1.641 ft)	For M6 thread	The protective tube, made of noncorrosive stainless steel, protects the inner fiber cable from any external forces.
	<b>FDP-1000</b> (1 m 3.281 ft)		
	<b>FDP-1500</b> (1.5 m 4.922 ft)		
	<b>FDP-N500</b> (0.5 m 1.641 ft)	For M4 thread	
	<b>FDP-N1000</b> (1 m 3.281 ft)		
	<b>FDP-N1500</b> (1.5 m 4.922 ft)		
Fiber bender	<b>FB-1</b>	The fiber bender bends the sleeve part of the fiber head at the proper radius. (Note 1)	
Universal sensor mounting stand (Note 2)	<b>MS-AJ1-F</b>	Horizontal mounting type	Mounting stand assembly for fiber (For M3, M4 or M6 threaded head fiber)
	<b>MS-AJ2-F</b>	Vertical mounting type	
Single-core holder	<b>FX-AT15A</b>	The incident light intensity may vary when using a multi-core fiber or a thin type sharp bending fiber. This holder suppresses the variation in the incident light intensity. Brown.	

Notes: 1) Do not bend the sleeve part of any side-view type fiber or ultra-small diameter head type fiber.  
2) Refer to p.953 for the universal sensor mounting stand **MS-AJ** series.

**Protective tube**

- **FTP-□**
- **FDP-□**

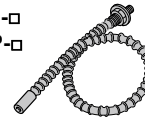

**Fiber bender**

- **FB-1**



**Universal sensor mounting stand**

Using the arm which enables adjustment in the horizontal direction, sensing can also be done from above an assembly line.

- **MS-AJ1-F** Swivel: 360° rotation

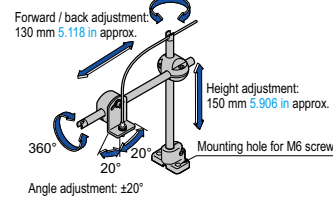

- **MS-AJ2-F** Swivel: 360° rotation

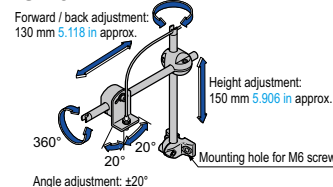

**Single-core holder**

- **FX-AT15A**



## SPECIFICATIONS

Item	Type Model No.	NPN output			PNP output		
		Red LED	Blue LED	Green LED	Red LED	Blue LED	Green LED
		<b>FX-411</b>	<b>FX-411B</b>	<b>FX-411G</b>	<b>FX-411P</b>	<b>FX-411BP</b>	<b>FX-411GP</b>
CE marking directive compliance	EMC Directive, RoHS Directive						
Supply voltage	12 to 24 V DC $\pm 10\%$ Ripple P-P 10% or less						
Power consumption	<p>&lt;Red LED type&gt; Normal operation: 960 mW or less (Current consumption 40 mA or less at 24 V supply voltage) ECO mode: 840 mW or less (Current consumption 35 mA or less at 24 V supply voltage)</p> <p>&lt;Blue LED / Green LED type&gt; Normal operation: 720 mW or less (Current consumption 30 mA or less at 24 V supply voltage) ECO mode: 580 mW or less (Current consumption 24 mA or less at 24 V supply voltage)</p>						
Output	<p>&lt;NPN output type&gt; NPN open-collector transistor</p> <ul style="list-style-type: none"> <li>Maximum sink current: 100 mA  <div style="margin-left: 20px;">(50 mA, if five, or more, amplifiers are connected in cascade)</div> </li> <li>Applied voltage: 30 V DC or less (between output and 0 V)</li> <li>Residual voltage: 1.5 V or less  <div style="margin-left: 20px;">[ at 100 mA sink current  <div style="margin-left: 20px;">(50 mA, if five, or more, amplifiers are connected in cascade)</div> </div> </li> </ul>			<p>&lt;PNP output type&gt; PNP open-collector transistor</p> <ul style="list-style-type: none"> <li>Maximum source current: 100 mA  <div style="margin-left: 20px;">(50 mA, if five, or more, amplifiers are connected in cascade)</div> </li> <li>Applied voltage: 30 V DC or less (between output and +V)</li> <li>Residual voltage: 1.5 V or less  <div style="margin-left: 20px;">[ at 100 mA sink current  <div style="margin-left: 20px;">(50 mA, if five, or more, amplifiers are connected in cascade)</div> </div> </li> </ul>			
	Utilization category	DC-12 or DC-13					
	Output operation	Switchable either Light-ON or Dark-ON					
	Short-circuit protection	Incorporated					
Response time	150 $\mu$ s or less (FAST), 500 $\mu$ s or less (STD), 4.5 ms or less (U-LG) selectable with setting switch						
Operation indicator	Orange LED (lights up when the output is ON)						
Stability indicator	Green LED (lights up under stable light received condition or stable dark condition)						
Timer function	<p>Incorporated with variable ON-delay / OFF-delay / ONE SHOT timer, switchable either effective or ineffective.</p> <p>[ Timer period (Note 3): 1 ms to 3 sec. approx. (1 to 10 ms: Setting possible in units of 1 ms, 10 to 100 ms: Setting possible in units of 10 ms, 100 to 500 ms: Setting possible in units of 50 ms, 500 ms to 1 sec.: Setting possible in units of 100 ms, 1 to 3 sec.: Setting possible in units of 500 ms) ]</p>						
Automatic interference prevention function	Incorporated (Up to four sets of fiber heads can be mounted close together. However, U-LG mode is 8 fiber heads.)(Note 4)						
Environmental resistance	Pollution degree	3 (Industrial environment)					
	Ambient temperature	<p>-10 to +55 °C <b>-14 to +131 °F</b> (If 4 to 7 units are connected in cascade: -10 to +50 °C <b>+14 to +122 °F,</b>  if 8 to 16 units are connected in cascade: -10 to +45 °C <b>+14 to +113 °F</b>)  (No dew condensation or icing allowed), Storage: -20 to +70 °C <b>-4 to +158 °F</b></p>					
	Ambient humidity	35 to 85 % RH, Storage: 35 to 85 % RH					
	Ambient illuminance	Incandescent light: 3,000 lx or less at the light-receiving face					
	Voltage withstandability	1,000 V AC for one min. between all supply terminals connected together and enclosure (Note 5)					
	Insulation resistance	20 M $\Omega$ , or more, with 250 V DC megger between all supply terminals connected together and enclosure (Note 5)					
	Vibration resistance	10 to 150 Hz frequency, 0.75 mm <b>0.030 in</b> double amplitude in X, Y and Z directions for two hours each					
	Shock resistance	98 m/s <sup>2</sup> acceleration (10 G approx.) in X, Y and Z directions five times each					
Emitting element (modulated)	Red LED	Blue LED	Green LED	Red LED	Blue LED	Green LED	
Peak emission wavelength	650 nm <b>0.026 mil</b>	470 nm <b>0.019 mil</b>	525 nm <b>0.021 mil</b>	650 nm <b>0.026 mil</b>	470 nm <b>0.019 mil</b>	525 nm <b>0.021 mil</b>	
Material	Enclosure: Heat-resistant ABS, Case cover: Polycarbonate						
Cable length	Total length up to 100 m <b>328.084 ft</b> (50 m <b>164.042 ft</b> for 5 to 8 units, 20 m <b>65.617 ft</b> for 9 to 16 units) is possible with 0.3 mm <sup>2</sup> , or more, cable.						
Weight	Net weight: 20 g approx., Gross weight: 30 g approx.						

Notes: 1) Where measurement conditions have not been specified precisely, the conditions used were an ambient temperature of +23 °C **+73.4 °F**.

2) The **FX-412** has a threshold value adjuster that can be adjusted with your fingers.

3) For models manufactured up until June 2005, the timer period is approx. 1 to 500 ms.

4) When the power supply is switched on, the light emission timing is automatically set for interference prevention.

5) The voltage withstandability and the insulation resistance values given in the above table are for the amplifier only.

FIBER SENSORS

LASER SENSORS

PHOTO-ELECTRIC SENSORS

MICRO PHOTO-ELECTRIC SENSORS

AREA SENSORS

SAFETY LIGHT CURTAINS / SAFETY COMPONENTS

PRESSURE / FLOW SENSORS

INDUCTIVE PROXIMITY SENSORS

PARTICULAR USE SENSORS

SENSOR OPTIONS

SIMPLE WIRE-SAVING UNITS

WIRE-SAVING SYSTEMS

MEASUREMENT SENSORS

STATIC CONTROL DEVICES

LASER MARKERS

PLC

HUMAN MACHINE INTERFACES

ENERGY MANAGEMENT SOLUTIONS

FA COMPONENTS

MACHINE VISION SYSTEMS

UV CURING SYSTEMS

Selection Guide

Fibers

Fiber Amplifiers

Other Products

**FX-500****FX-550****FX-100****FX-410**

FIBER SENSORS  
LASER SENSORS  
PHOTO-ELECTRIC SENSORS  
MICRO PHOTO-ELECTRIC SENSORS  
AREA SENSORS  
SAFETY LIGHT CURTAINS / SAFETY COMPONENTS  
PRESSURE / FLOW SENSORS  
INDUCTIVE PROXIMITY SENSORS  
PARTICULAR USE SENSORS  
SENSOR OPTIONS  
SIMPLE WIRE-SAVING UNITS  
WIRE-SAVING SYSTEMS  
MEASURE-MENT SENSORS  
STATIC CONTROL DEVICES  
LASER MARKERS  
PLC  
HUMAN MACHINE INTERFACES  
ENERGY MANAGEMENT SOLUTIONS  
FA COMPONENTS  
MACHINE VISION SYSTEMS  
UV CURING SYSTEMS

## I/O CIRCUIT DIAGRAMS

### FX-41□ NPN output type

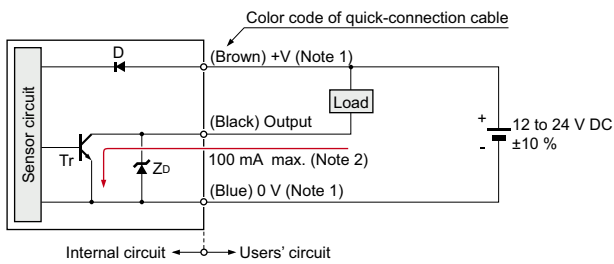

Notes: 1) The quick-connection sub cable does not have +V (brown) and 0 V (blue). The power is supplied from the connector of the main cable.  
2) 50 mA max., if five amplifiers, or more, are connected together.

Symbols ... D : Reverse supply polarity protection diode  
Zd: Surge absorption zener diode  
Tr : NPN output transistor

### FX-41□P PNP output type

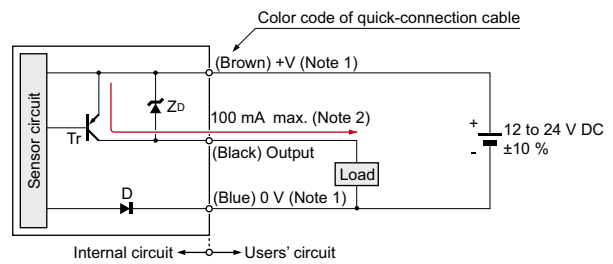

Notes: 1) The quick-connection sub cable does not have +V (brown) and 0 V (blue). The power is supplied from the connector of the main cable.  
2) 50 mA max., if five amplifiers, or more, are connected together.

Symbols ... D : Reverse supply polarity protection diode  
Zd: Surge absorption zener diode  
Tr : PNP output transistor

## PRECAUTIONS FOR PROPER USE

Refer to p.1552~ for general precautions.



- Never use this product as a sensing device for personnel protection.
- In case of using sensing devices for personnel protection, use products which meet laws and standards, such as OSHA, ANSI or IEC etc., for personnel protection applicable in each region or country.

### Part description

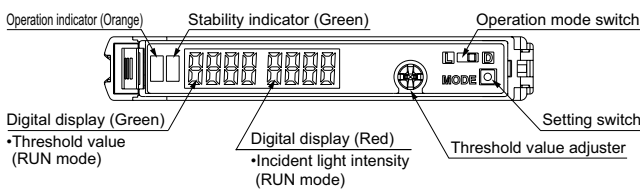

### Wiring

- Make sure that the power supply is off while wiring.
- Verify that the supply voltage variation is within the rating.
- Take care that if a voltage exceeding the rated range is applied, or if an AC power supply is directly connected, the product may get burnt or damaged.
- In case noise generating equipment (switching regulator, inverter motor, etc.) is used in the vicinity of this product, connect the frame ground (F.G.) terminal of the equipment to an actual ground.
- If power is supplied from a commercial switching regulator, ensure that the frame ground (F.G.) terminal of the power supply is connected to an actual ground.
- Take care that short circuit of the load wrong wiring may burn or damage the product.
- Do not run the wires together with high-voltage lines or power lines or put them in the same raceway. This can cause malfunction due to induction.
- Extension up to total 100 m **328.084 ft** (if 5 to 8 units are connected in cascade: 50 m **164.042 ft**, if 9 to 16 units are connected in cascade: 20 m **65.617 ft**) is possible with 0.3 mm<sup>2</sup>, or more, cable. However, in order to reduce noise, make the wiring as short as possible.
- Take care that cable extension increases the residual voltage.

### Mounting

- Make sure that the power supply is off while connecting/disconnecting the amplifiers and the quick-connection cables.

#### How to mount the amplifier

- ① Fit the rear part of the mounting section of the amplifier on a width DIN rail.
- ② Press down the rear part of the mounting section of the unit on the width DIN rail and fit the front part of the mounting section to the DIN rail.

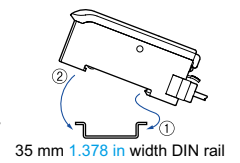

#### How to remove the amplifier

- ① Push the amplifier forward.
- ② Lift up the front part of the amplifier to remove it.

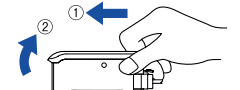

Note: Take care that if the front part is lifted without pushing the amplifier forward, the hook on the rear portion of the mounting section is likely to break.

### Fiber installation

- Insert the fiber into the amplifier after attaching the attachment. Refer to the "Instruction Manual" included with the fiber for details.

- ① Push the fiber lock lever down.
- ② Slowly insert the fiber into the insertion slot until it stops. (Note 1)
- ③ Push the fiber lock lever back up until it stops.

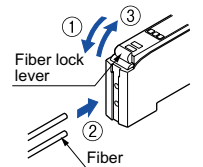

Notes: 1) Note that if the fiber is not fully inserted, the sensing distance will decrease. Also note that the bending-resistant fiber may bend during insertion.  
2) In case of coaxial reflective type fibers, mount the central fiber (single-core) to the emitter part and the peripheral fiber (multi-core) to the receiver. Note that sensing precision will deteriorate when done in reverse.

Selection Guide  
Fibers  
Fiber Amplifiers  
Other Products

**FX-500**  
**FX-550**  
**FX-100**  
**FX-410**

## PRECAUTIONS FOR PROPER USE

Refer to p.1552~ for general precautions.

### Cascading

- Make sure that the power supply is off while adding or removing the amplifiers.
- Make sure to check the allowable ambient temperature, as it depends on the number of amplifiers connected in cascade.
- In case two, or more, amplifiers are connected in cascade, make sure to mount them on a DIN rail.
- When the amplifiers move on the DIN rail depending on the attaching condition or the amplifiers are mounted close to each other in cascade, fit them between the optional end plates (**MS-DIN-E**) mounted at the two ends.
- Up to maximum 15 amplifiers can be added (total 16 amplifiers connected in cascade.)
- When connecting more than two amplifiers in cascade, use the sub cable (**CN-71-C**) as the quick-connection cable for the second amplifier onwards.
- When connecting amplifiers not close to each other in parallel, be sure to mount the optional end plate (**MS-DIN-E**) at both sides of each amplifier or affix the communication window seal of the optional fiber amplifier protection seal (**FX-MB1**) to the communication windows. For details, refer to the instruction manual enclosed with the **FX-MB1**.
- When the different LED (red / blue / green) types are connected in cascade, mount the identical models together.
- When this product is used with the other digital fiber amplifiers, be sure to place this product to the left most position (When you look from the connector side). If this product is not placed to the leftmost position, this product may not operate properly.

### Cascading method

- ① Mount the amplifiers, one by one, on the DIN rail.
- ② Slide the amplifiers next to each other, and connect the quick-connection cables.
- ③ Mount the optional end plates (**MS-DIN-E**) at both the ends to hold the amplifiers between their flat sides.
- ④ Tighten the screws to fix the end plates.

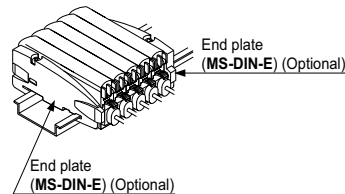
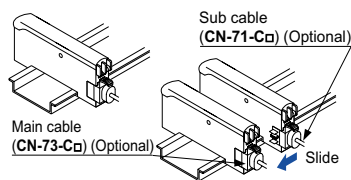

### Dismantling

- ① Loosen the screws of the end plates.
- ② Remove the end plates.
- ③ Slide the amplifiers and remove them one by one.

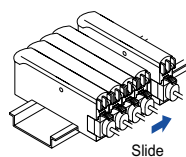

### Switching output operation

- The operation selection switch can be used to display different output operations (L-ON / D-ON) on the digital display.

#### When set to Dark-ON (D-ON)



#### When set to Light-ON (L-ON)



### Threshold value (sensitivity) adjustment

- ① Check the incident light intensity [in the digital display (red)] when a sensing object is placed in the sensing position.
- ② Check the incident light intensity [in the digital display (red)] when the sensing object is removed from the sensing position.
- ③ Turn the threshold value adjuster to the threshold value [in the digital display (green)] that is the value in between ① and ②. (The threshold value is automatically written to the EEPROM.)

### Threshold value setting method

- When the threshold value adjuster is turned clockwise, the threshold value increases. When the threshold value adjuster is turned counterclockwise, the threshold value decreases.



- If there is a sufficient level of margin in the incident light intensity, the stability indicator (green) will light up.

### Mode selection

- When the setting switch is pressed and held for 2 sec. or more, "SET" mode (mode setting screen) is activated.
- If the setting switch is pressed while in "SET" mode, the mode will change.
- If the threshold value adjuster is turned while a mode is active, the setting item will change and blink.
- When the setting switch is pressed at the item you would like to set, it blinks 3 times and then the setting is confirmed and the mode switches to the next mode.
- If the setting switch is pressed and held for 2 sec. or more or do not press any key for 15 sec. while "SET" mode is active, the mode will switch automatically to "RUN" mode.

FIBER SENSORS

LASER SENSORS

PHOTO-ELECTRIC SENSORS

MICRO PHOTO-ELECTRIC SENSORS

AREA SENSORS

SAFETY LIGHT CURTAINS / SAFETY COMPONENTS

PRESSURE / FLOW SENSORS

INDUCTIVE PROXIMITY SENSORS

PARTICULAR USE SENSORS

SENSOR OPTIONS

SIMPLE WIRE-SAVING UNITS

WIRE-SAVING SYSTEMS

MEASUREMENT SENSORS

STATIC CONTROL DEVICES

LASER MARKERS

PLC

HUMAN MACHINE INTERFACES

ENERGY MANAGEMENT SOLUTIONS

FA COMPONENTS

MACHINE VISION SYSTEMS

UV CURING SYSTEMS

Selection Guide

Fibers

Fiber Amplifiers

Other Products

**FX-500**

**FX-550**

**FX-100**

**FX-410**

**PRECAUTIONS FOR PROPER USE**

Refer to p.1552~ for general precautions.

**Mode table**

Mode	Factory setting	Description
Response time change mode	SPED 5td	The response time can be set.
Light-emitting amount selection mode (Note 1)	PEEL 0000	The light-emitting amount can be switched among four levels.
Timer setting mode	DEL4 non	Timer settings can be selected; Without timer / OFF-delay timer / ON-delay timer / ONE SHOT timer. Also the timer period can be set.
Digital display inversion mode	EWn off	The display on the digital display can be inverted.
Eco mode (Note 2)	Eco off	If no key is pressed for 20 sec. approx. while in "RUN" mode, the digital display turns off automatically. Press the setting switch or move the operation mode switch to make the display light up again. The digital display will light up when the threshold value adjuster is turned, but note that this will also cause the threshold value to change.
Peak / Bottom hold mode	Hold off	If the setting switch is pressed while "RUN" mode is active, the display will alternate between the peak hold value and the bottom hold value. (The display will refresh every 2 sec.) The display will return to normal if any operation other than threshold value setting is carried out.

Notes: 1) This mode is not incorporated in the blue LED type and green LED type.  
 2) While the peak / bottom hold mode is ON, the digital display is not turned off even if the Eco mode is set to ON.

**Key lock function**

- When the setting switch is pressed and held for 5 sec. while in 'RUN' mode, the key lock function can be set / canceled.
- When the key lock function is set to ON, even if the threshold value adjuster or the setting switch is operated, "Loc" is displayed and the key operation cannot be carried out.

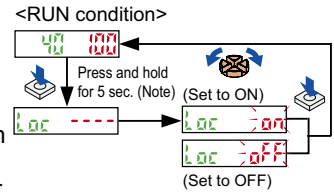

Note: Although the display changes to the indication of 'SET' condition 2 sec. after pressing the setting switch, keep pressing the switch. Furthermore, the sensor does not go into the key lock setting from 'SET' condition.

**Factory setting**

- When the setting switch is pressed and held for 10 sec., until "----" is displayed while in 'RUN' mode, the all settings are returned to the factory setting. (For the factory setting, refer to 'Mode table' in 'Mode selection'.)

**Error display indicator readings**

Display	Error description	Measures
Er-1	The load has short-circuited and excess current is flowing.	Turn off the power, then check the load.
Er-5	Communication error has occurred at time of connection.	Check if the mounted amplifiers are in close contact with each other.

**Others**

- This product has been developed / produced for industrial use only.
- Do not use during the initial transient time (0.5 sec.) after the power supply is switched on.
- This sensor is suitable for indoor use only.
- Do not use this sensor in places having excessive vapor, dust, etc., or where it may come in contact with corrosive gas.
- Take care that the sensor does not come in direct contact with oil, grease, organic solvents, such as, thinner etc., or strong acid, and alkaline.
- This sensor cannot be used in an environment containing inflammable or explosive gases.
- Never disassemble or modify the sensor.
- The changes to the settings are written to the EEPROM, but because the EEPROM has a limited service life, you should avoid changing the settings any more than 1 million times.

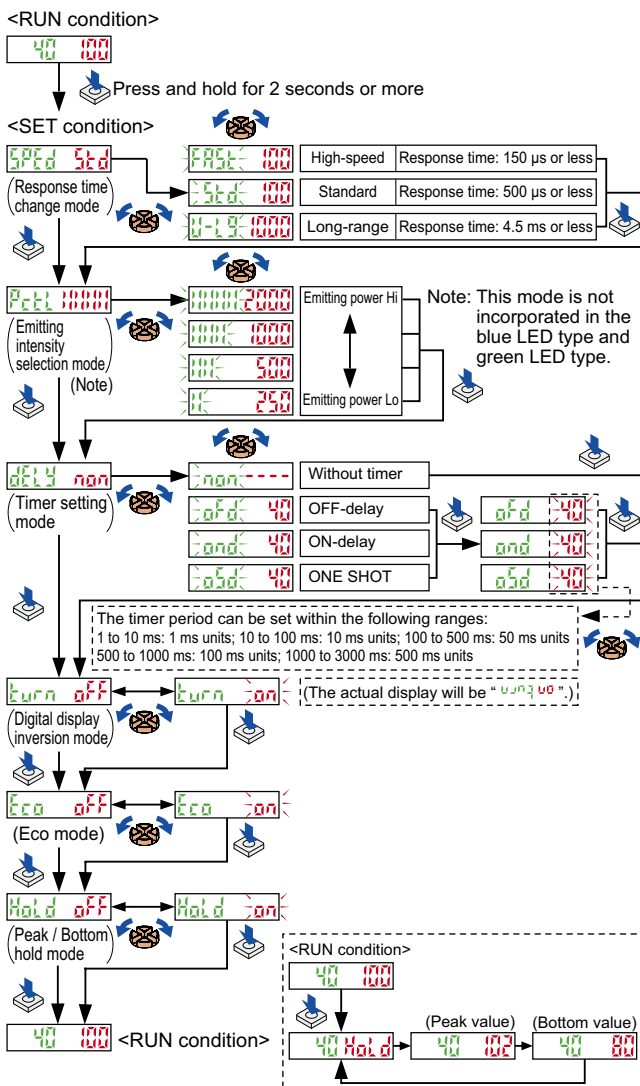

**DIMENSIONS (Unit: mm in)**

Refer to p.63~ for dimensions of the fibers.  
The CAD data can be downloaded from our website.

**FX-411□ FX-411□P Amplifier**

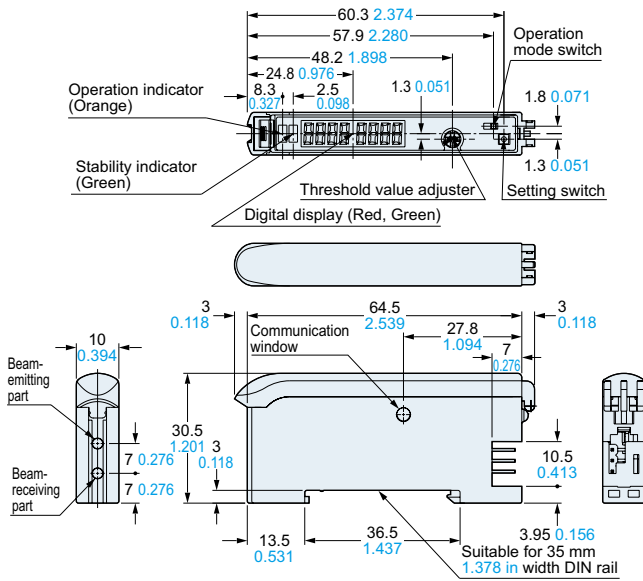

**FX-412□ Amplifier**

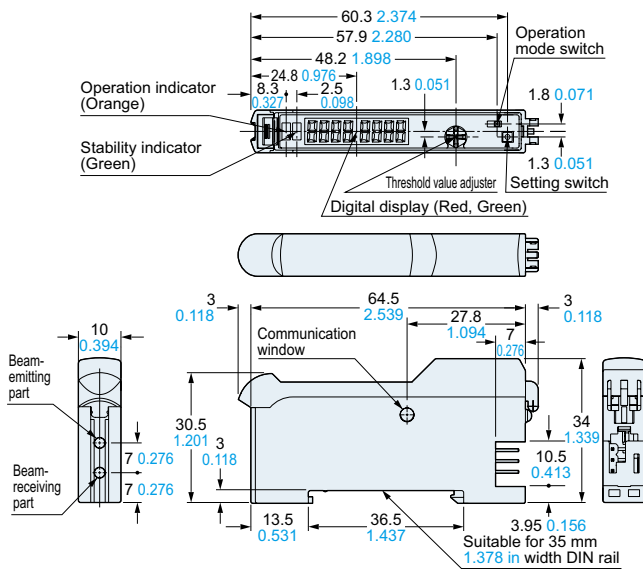

**CN-71-C1 CN-71-C2 CN-71-C5 Sub cable (Optional)**

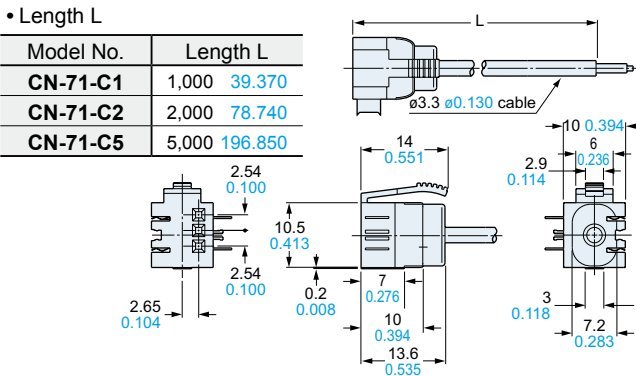

**CN-73-C1 CN-73-C2 CN-73-C5 Main cable (Optional)**

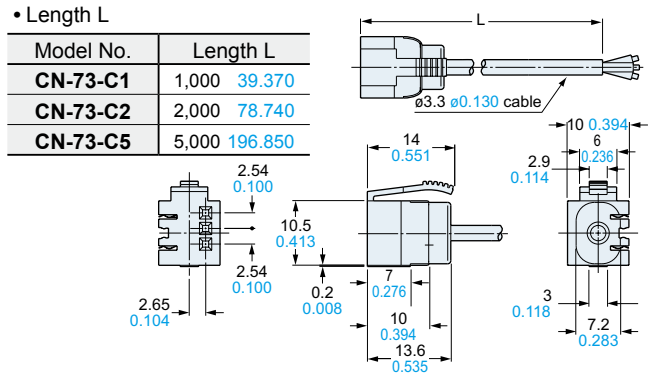

**MS-DIN-E End plate (Optional)**

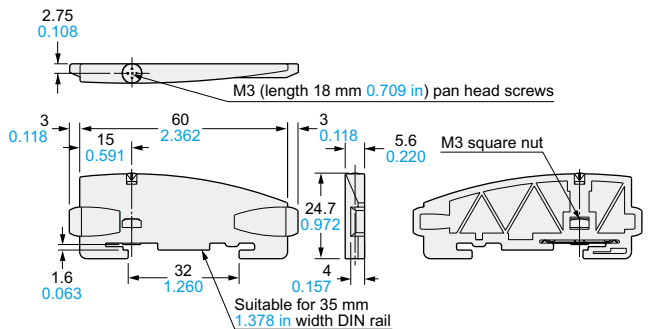

**MS-DIN-2 Amplifier mounting bracket (Optional)**

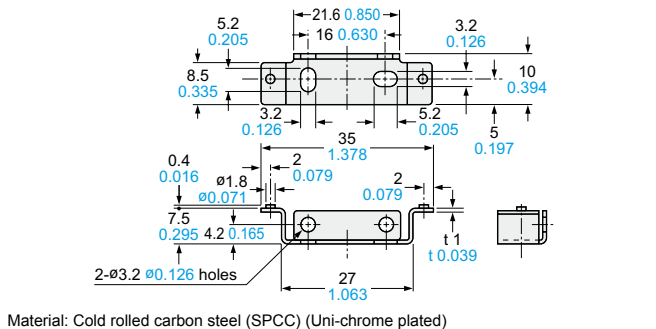

FIBER SENSORS

LASER SENSORS

PHOTO-ELECTRIC SENSORS

MICRO PHOTO-ELECTRIC SENSORS

AREA SENSORS

SAFETY LIGHT CURTAINS / SAFETY COMPONENTS

PRESSURE / FLOW SENSORS

INDUCTIVE PROXIMITY SENSORS

PARTICULAR USE SENSORS

SENSOR OPTIONS

SMILE WIRE-SAVING UNITS

WIRE-SAVING SYSTEMS

MEASUREMENT SENSORS

STATIC CONTROL DEVICES

LASER MARKERS

PLC

HUMAN MACHINE INTERFACES

ENERGY MANAGEMENT SOLUTIONS

FA COMPONENTS

MACHINE VISION SYSTEMS

UV CURING SYSTEMS

Selection Guide

Fibers

Fiber Amplifiers

Other Products

FX-500

FX-550

FX-100

FX-410