

Embedded Nano SD NAND Flash MKDNXXXGIL-XX

Industrial Grade Specification

Preliminary

**Ver.1.0
Oct.2020**

Revision History

Date	Rev.	Description
2020/10/31	1.0	Original version

MK Confidential

CONTENTS

1. Introduction.....	- 1 -
2. Product List.....	- 1 -
3. Features.....	1
4. Physical Characteristics.....	2
4.1. Temperature.....	2
5. Pin Assignments(SD Mode& SPI Mode).....	2
6. Usage.....	3
6.1 SD Bus Mode protocol.....	3
6.2. Card Initialize.....	5
6.3 DC Characteristics.....	7
7. Internal Information.....	8
7.1 Registers.....	8
7.1.1 OCR Register.....	9
7.1.2. CID Register.....	10
7.2.3. CSD Register.....	11
7.1.4. RCA Register.....	12
7.1.5. DSR Register.....	12
8. Power Scheme.....	13
8.1. Power Up.....	13
8.2 Power Up Time.....	13
8.2.1 Power On or Power Cycle.....	14
8.2.2 Power Supply Ramp Up.....	14
8.2.3 Power Supply Ramp Up.....	14
9. Package Dimensions.....	15
10. Reference Design.....	16

1. Introduction

MK Nano SD NAND is an embedded storage solution designed in a LGA package form. The operation of SD is similar to an SD card which is an commercial standard.

Nano SD NAND consists of NAND flash and a high performance controller. 3.3V supply voltage is required for the NAND area (VCC).

Nano SD NAND is fully compliant with SD3.0 interface, which allows most of general CPU to utilize.

Nano SD NAND has high performance at a competitive cost, high quality and low power consumption.

2. Product List

Part Number	Flash Type	Capacity	Actual Capacity	Package	Size
MKDN032GIL-AA	SLC	32Gbit	3696MByte	LGA-16	9x12.5mm
MKDN064GIL-AA	SLC	64Gbit	7382MByte	LGA-16	9x12.5mm

3. Features

- Support up to 208MHz clock frequency
- SD-protocol compatible
- Supports SPI Mode
- Built-in HW ECC Engine and highly reliable NAND management mechanism
- Write speed up to class 10
- Smaller package LGA-8

4. Physical Characteristics

4.1. Temperature

1) Operation Conditions

Temperature Range: Ta = -25 to 85 degrees centigrade

2) Storage Conditions

Temperature Range: Tstg = -55 to 150 degrees centigrade

5. Pin Assignments(SD Mode& SPI Mode)

TOP VIEW

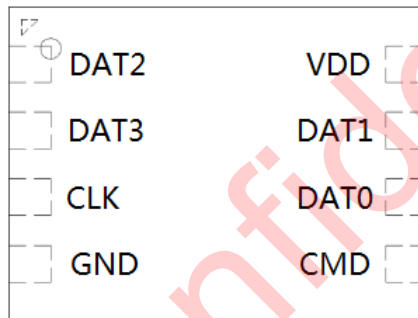

Name	SD Mode		SPI Mode	
	Type	Description	Type	Description
DAT2	I/O/PP	Data Line [Bit 2]	RSV	Reserved
DAT3	I/O/PP	Data Line [Bit 3]	I3	Chip Select (neg true)
CLK	I	Clock	I	Clock
GND	S	Supply voltage ground	S	Supply voltage ground
VDD	S	Supply voltage	S	Supply voltage
DAT1	I/O/PP	Data Line [Bit 1]	RSV	Reserved
DAT0	I/O/PP	Data Line [Bit 0]	O/PP	Data Out
CMD	PP	Command/Response	I	Data In

- a. Type Key: S=power supply; I= input; O=output using push-pull drivers; PP=I/O using push-pull drivers.
- b. The extended DAT lines (DAT1-DAT3) are input on power up. They start to operate as DAT lines after the SET_BUS_WIDTH Type Key: S=power supply; I=input; O=output using push-pull drivers; PP=I/O using push-pull drivers.
- c. At power up this line has a 50 kilohm pull-up enabled in the card. This resistor serves two functions: Card detection and Mode Selection. For Mode Selection, the host can drive the line high or let it be pulled high to select SD mode. If the host wants to select SPI mode it should drive the line low. For Card detection, the host detects that the line is pulled high. This pull-up should be disconnected by the user, during regular data transfer, with SET_CLR_CARD_DETECT (ACMD42) command.

6. Usage

6.1 SD Bus Mode protocol

The SD bus allows the dynamic configuration of the number of data line from 1 to 4 Bi-directional data signal. After power up by default, the SD card will use only DAT0. After initialization, host can change the bus width.

Multiplied SD cards connections are available to the host. Common VDD, VSS and CLK signal connections are available in the multiple connections. However, Command, Respond and Data lined (DAT0-DAT3) shall be divided for each device from host.

This feature allows easy trade off between hardware cost and system performance. Communication over the SD bus is based on command and data bit stream initiated by a start bit and terminated by stop bit.

Command: Commands are transferred serially on the CMD line. A command is a token to starts an operation from host to the device. Commands are sent to an addressed single card (addressed Command) or to all connected cards (Broad cast command).

Response: Responses are transferred serially on the CMD line. A response is a token to answer to a previous received command. Responses are sent from an addressed single card or from all connected cards.

Data: Data can be transfer from the card to the host or vice versa. Data is transferred via the data lines.

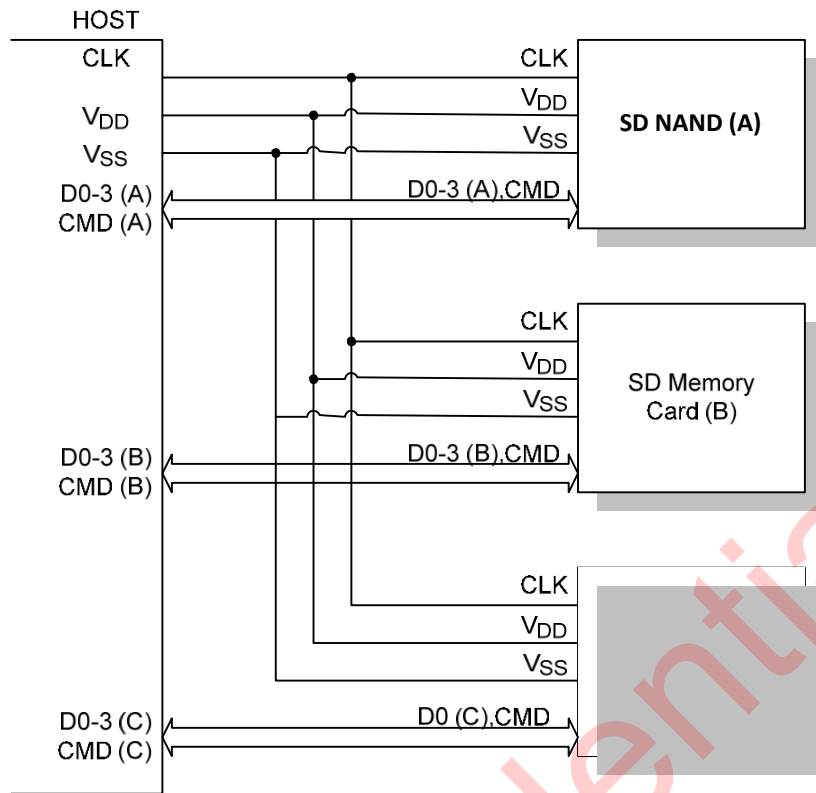

CLK	Host card Clock signal
CMD	Bi-directional Command/ Response Signal
DAT0 - DAT3	4 Bi-directional data signal
V _{DD}	Power supply
V _{SS}	GND

6.2. Card Initialize

To initialize the SD NAND, follow the following procedure is recommended example.

1) Supply Voltage for initialization.

Host System can apply the Operating Voltage from initialization to the card. Apply more than 74 cycles of Dummy-clock to the SD card.

2) Select operation mode (SD mode or SPI mode)

In case of SPI mode operation, host should drive 1 pin (CD/DAT3) of SD Card I/F to “Low” level. Then, issue CMD0. In case of SD mode operation, host should drive or detect 1 pin of SD Card I/F (Pull up register of 1 pin is pull up to “High” normally).

Card maintain selected operation mode except re-issue of CMD0 or power on below is SD mode initialization procedure.

3) Send the ACMD41 with Arg = 0 and identify the operating voltage range of the Card.

4) Apply the indicated operating voltage to the card.

Reissue ACMD41 with apply voltage storing and repeat ACMD41 until the busy bit is cleared. (Bit 31 Busy = 1) If response time out occurred, host can recognize not SD Card.

5) Issue the CMD2 and get the Card ID (CID).

Issue the CMD3 and get the RCA. (RCA value is randomly changed by access, not equal zero)

6) Issue the CMD7 and move to the transfer state.

If necessary, Host may issue the ACMD42 and disabled the pull up resistor for Card detect.

7) Issue the ACMD13 and poll the Card status as SD Memory Card. Check SD_CARD_TYPE value. If significant 8 bits are “all zero”, that means SD Card. If it is not, stop initialization.

8) Issue CMD7 and move to standby state. Issue CMD9 and get CSD.

Issue CMD10 and get CID.

9) Back to the Transfer state with CMD7.

Issue ACMD6 and choose the appropriate bus-width.

Then the Host can access the Data between the SD card as a storage device.

Normal SD initial flow

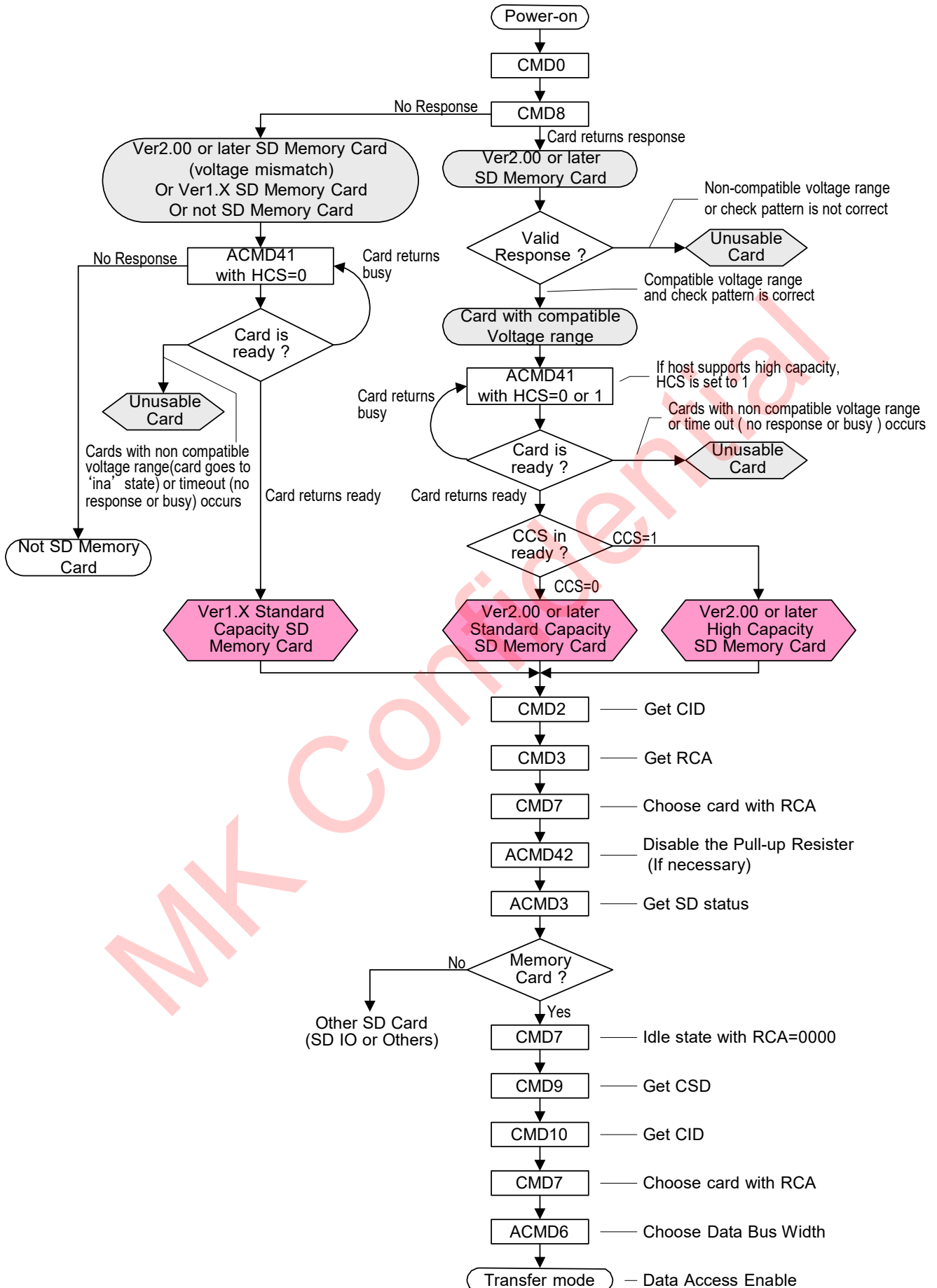

SD card Initialize Procedure

7.1.4. RCA Register

SD3.0 initial flow for UHS-I(IO 1.8v) switch

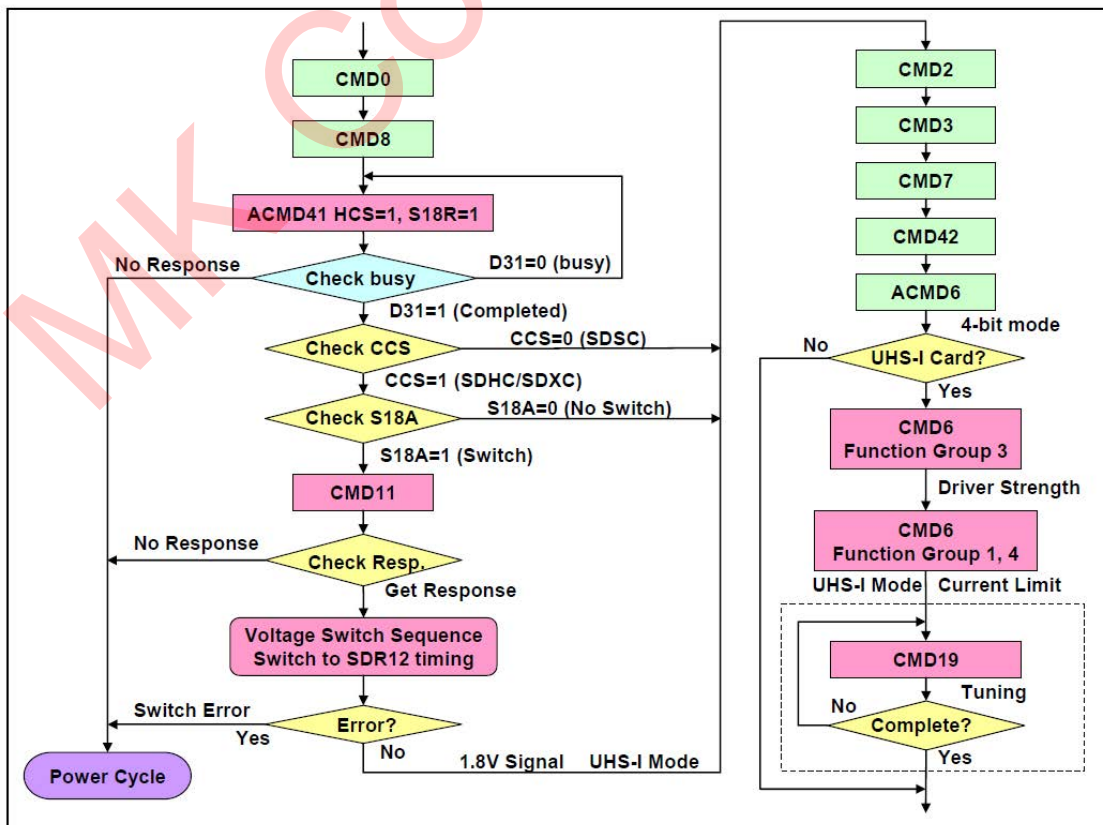
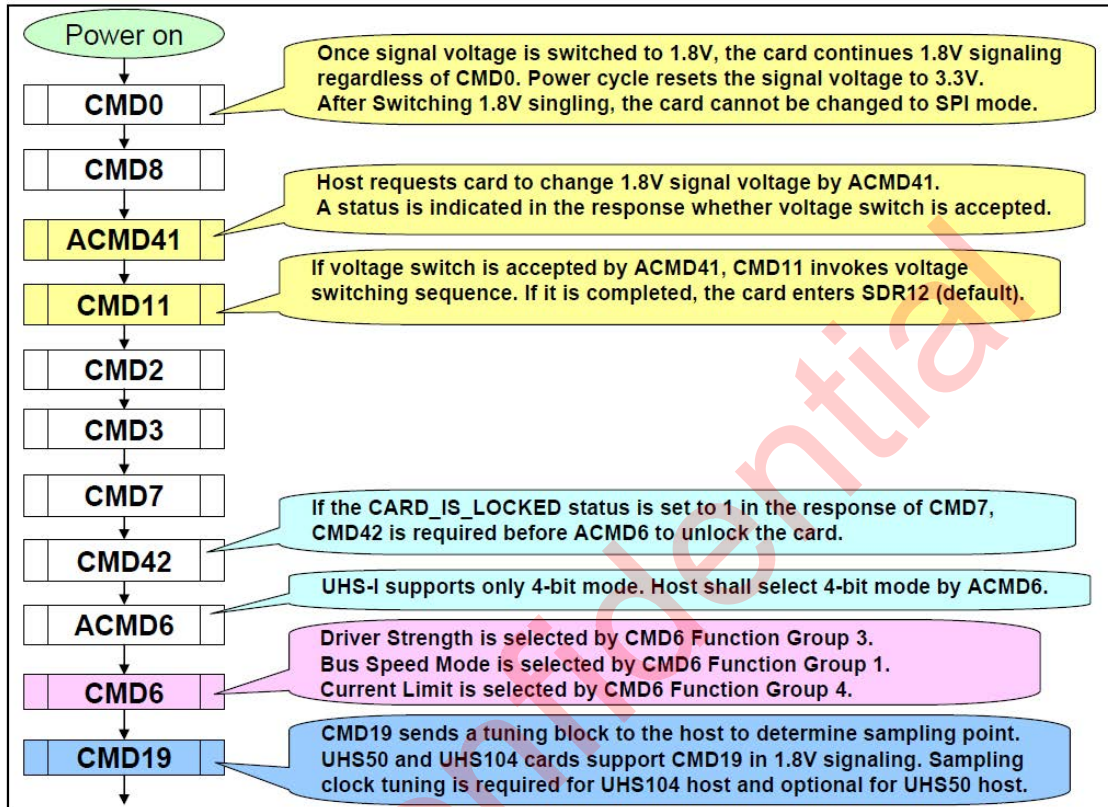

6.3 DC Characteristics

DC Characteristics

Item	Symbol	MIN.	MAX.	Unit	Note
Supply Voltage	VDD	2.7	3.6	V	
Input Voltage	High Level	$V_{DD} \times 0.625$	$V_{DD} + 0.3$	V	
	Low Level	$V_{SS} - 0.3$	$V_{DD} \times 0.25$	V	
Output Voltage	High Level	$V_{DD} \times 0.75$	—	V	$I_{OH} = -2\text{mA}$, $V_{DD} = V_{DD \text{ min}}$
	Low Level	—	$V_{DD} \times 0.125$	V	$I_{OL} = 2\text{mA}$, $V_{DD} = V_{DD \text{ min}}$
Standby Current	ICC1	—	0.25 (32Gb)	mA	$V_{DD} = 3.6\text{V}$, Clock 25MHz
		—	0.05		$V_{DD} = 3.3\text{V}$, Clock STOP, $T_a = 25^\circ\text{C}$
Operation Current (*)	Write	—	30 (32Gb)	mA	3.3V / 25MHz, 50MHz
	Read	—	28 (32Gb)		
Input Voltage Setup Time	Vrs	—	250	ms	From 0V to VDD min

*) Peak Current: RMS value over a 10usec period

Peak Voltage and Leak Current

Item	Symbol	Min.	Max.	Unit	Note
Peak voltage on all lines		-0.3	$V_{DD} + 0.3$	V	
Input Leakage Current for all pins		-10	10	uA	
Output Leakage Current for all outputs		-10	10	uA	

Signal Capacitance

Item	Symbol	Min.	Max.	Unit	Note
Pull up Resistance	RCMD RDATA	10	100	k Ω	
Total bus capacitance for each signal line	CL	—	40	pF	1 card $C_{HOST} + C_{BUS} \leq 30\text{pF}$
Card capacitance for signal pin	CCARD	—	10	pF	
Pull up Resistance inside card (pin1)	RDATA3	10	90	k Ω	
Capacity Conncted to Power line	CC	—	5	uF	

7. Internal Information

7.1 Registers

The Nano SD NAND has six registers and SD Status information: OCR, CID, CSD, RCA, DSR, SCR and SD Status. DSR IS NOT SUPPORTED in this card.

There are two types of register groups.

MMC compatible registers: OCR, CID, CSD, RCA, DSR, and SCR SD card Specific: SD Status

SD card Registers

Resister Name	Bit Width	Description
OCR	32	Operation Conditions (VDU Voltage Profile and Busy Status)
CID	128	Card Identification information
CSD	128	Card specific information
RCA	16	Relative Card Address
DSR	16	Not Implemented (Programmable Card Driver): Driver Stage Register
SCR	64	SD Memory Card's special features
SD Status	512	Status bits and Card features

MK Confidential

7.1.1 OCR Register

This 32-bit register describes operating voltage range and status bit in the power supply.

OCR register definition

OCR bit	VDD voltage window	Initial	
		32Gb	64Gb
31	Card power up status bit(busy)	"0" = busy "1" =	
30	Card Capacity Status	"0"= SD Memory Card	
29-25	reserved	All '0'	
24	Switching to 1.8V Accepted(S18A)	0	
23	3.6 - 3.5	1	
22	3.5 - 3.4	1	
21	3.4 - 3.3	1	
20	3.3 - 3.2	1	
19	3.2 - 3.1	1	
18	3.1 - 3.0	1	
17	3.0 - 2.9	1	
16	2.9 - 2.8	1	
15	2.8 - 2.7	1	
14	Reserved	0	
13	Reserved	0	
12	Reserved	0	
11	Reserved	0	
10	Reserved	0	
9	Reserved	0	
8	Reserved	0	
7	Reserved for Low Voltage Range	0	
6	Reserved	0	
5	Reserved	0	
4	Reserved	0	
3-0	reserved	All '0'	

bit 23-4: Describes the SD Card Voltage

bit 31 indicates the card power up status. Value "1" is set after power up and initialization procedure has been completed.

7.1.2. CID Register

The CID (Card Identification) register is 128-bit width. It contains the card identification information. (Refer Appendix 3. for the detail) The Value of CID Register is vender specific.

Table 11: CID Register

Field	Width	CID-slice	Initial Value			
				32Gb	64Gb	
MID	8	[127:120]	TB			
OID	16	[119:104]	TBD			
PNM	40	[103:64]	TBD	TBD	TBD	--
PRV	8	[63:56]	TB			
PSN	32	[55:24]	(a) (Product serial number)			
-	4	[23:20]	All "0b"			
MDT	12	[19:8]	(a) (Manufacture date)			
CRC	7	[7:1]	(b) (CRC)			
-	1	[0:0]	1b			

(a): Depends on the SD Card. Controlled by Production Lot.

(b) Depends on the CID Register

MK Confidential

7.2.3. CSD Register

CSD is Card-Specific Data register provides information on 128bit width. Some field of this register can writable by PROGRAM_CSD (CMD27).

CSD Register

Field	Width	Cell Type	CSD Slice	Initial Value			
					32Gb	64Gb	
CSD STRUCTURE	2	R	[127:126]	01b			
-	6	R	[125:120]	All "0b"			
TAAC	8	R	[119:112]	0 0001 110b (1ms)			
NSAC	8	R	[111:104]	00000000			
TRAN SPEED	8	R	[103:96]	0 0110 010b			
CCC	12	R	[95:84]	0101 1011 0101			
READ BL LEN	4	R	[83:80]	1001b			
READ BL PARTIAL	1	R	[79:79]	0b			
WRITE BLK MISALIG	1	R	[78:78]	0b			
READ BLK MISALIGN	1	R	[77:77]	0b			
DSR IMP	1	R	[76:76]	0b			
-	6	R	[75:70]	All "0b"			
C SIZE	22	R	[69:48]	TBD	TBD	TBD	--
-	1	R	[47:47]	0b			
ERASE BLK EN	1	R	[46:46]	1b			
SECTOR SIZE	7	R	[45:39]	11 1111 1			
WP GRP SIZE	7	R	[38:32]	000 0000			
WP GRP ENABLE	1	R	[31:31]	0b			
-	2	R	[30:29]	00b			
R2W FACTOR	3	R	[28:26]	010b			
WRITE BL LEN	4	R	[25:22]	1001b			
WRITE BL PARTIAL	1	R	[21:21]	0b			
-	2	R	[20:16]	All "0b"			
FILE FORMAT GRP	1	R	[15:15]	0b			
COPY	1	R/W ⁽¹⁾	[14:14]	0b			
PERM WRITE PROTE	1	R/W ⁽¹⁾	[13:13]	0b			
TMP WRITE PROTEC	1	R/W	[12:12]	0b			
FILE FORMAT	2	R	[11:10]	00b			
-	2	R	[9:8]	All "0b"			
CRC	7	R/W	[7:1]	(CRC)			
-	1	-	[0:0]	1b			

Cell Type: R: Read Only, R/W: Writable and Readable, R/W⁽¹⁾: One-time Writable / Readable

Note: Erase of one data block is not allowed in this card. This information is indicated by "ERASE_BLK_EN".

Host System should refer this value before one data block size erase.

7.1.4. RCA Register

The writable 16bit relative card address register carries the card address in SD Card mode.

7.1.5. DSR Register

This register is not implemented on this car

MK Confidential

8. Power Scheme

8.1. Power Up

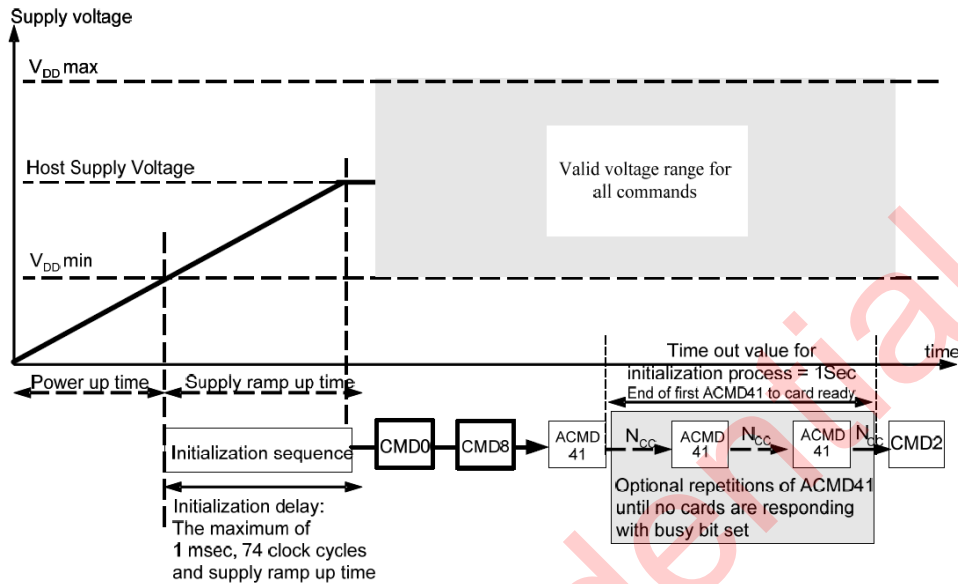

'Power up time' is defined as voltage rising time from 0 volt to $V_{DD\ min}$.

'Supply ramp up time' provides the time that the power is built up to the operating level (Host Supply Voltage) and the time to wait until the Nano SD NAND can accept the first command. The host shall supply power to the card so that the voltage is reached to $V_{DD\ min}$ within 250ms and start to supply at least 74 SD clocks to the Nano SD NAND with keeping CMD line to high.

8.2 Power Up Time

Host needs to keep power line level less than 0.5V and more than 1ms before power ramp up.

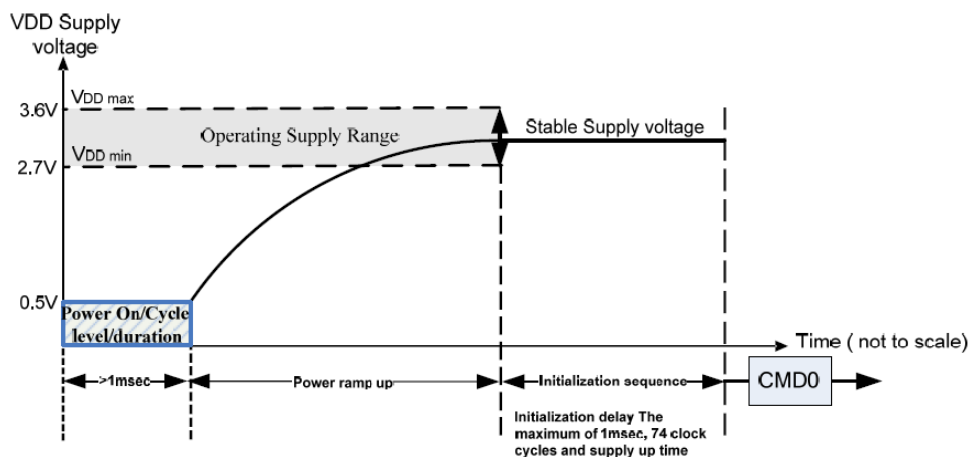

8.2.1 Power On or Power Cycle

Followings are requirements for Power on and Power cycle to assure a reliable Tailor™ SD hard reset.

- (1) Voltage level shall be below 0.5V
- (2) Duration shall be at least 1ms.

8.2.2 Power Supply Ramp Up

The power ramp up time is defined from 0.5V threshold level up to the operating supply voltage which is stable between VDD(min.) and VDD(max.) and host can supply SDCLK.

Followings are recommendation of Power ramp up:

- (1) Voltage of power ramp up should be monotonic as much as possible.
- (2) The minimum ramp up time should be 0.1ms.
- (3) The maximum ramp up time should be 35ms for 2.7-3.6V power supply.

8.2.3 Power Supply Ramp Up

When the host shuts down the power, the VDD shall be lowered to less than 0.5Volt for a minimum period of 1ms. During power down, DAT, CMD, and CLK should be disconnected or driven to logical 0 by the host to avoid a situation that the operating current is drawn through the signal lines.

If the host needs to change the operating voltage, a power cycle is required. Power cycle means the power is turned off and supplied again. Power cycle is also needed for accessing cards that are already in Inactive State. To create a power cycle the host shall follow the power down description before power up the card (i.e. the VDD shall be once lowered to less than 0.5Volt for a minimum period of 1ms).

9. Package Dimensions

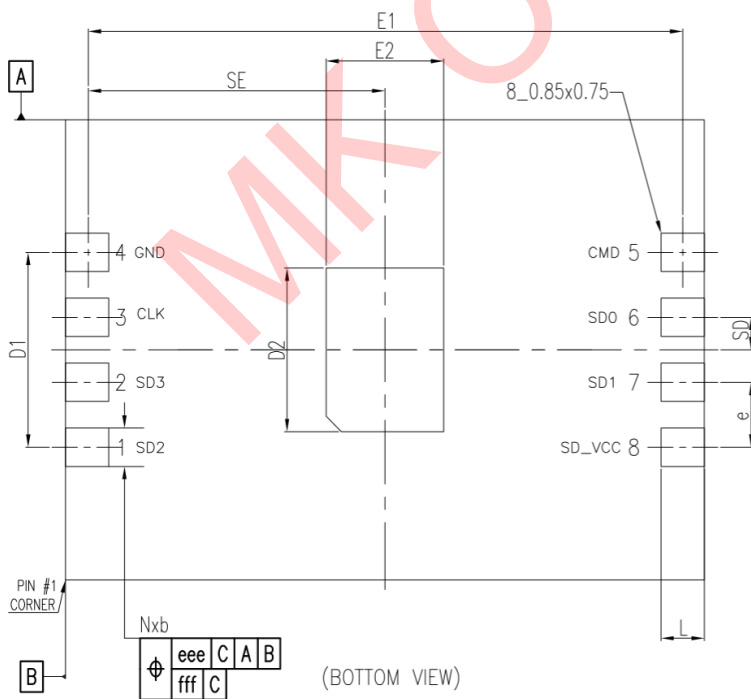
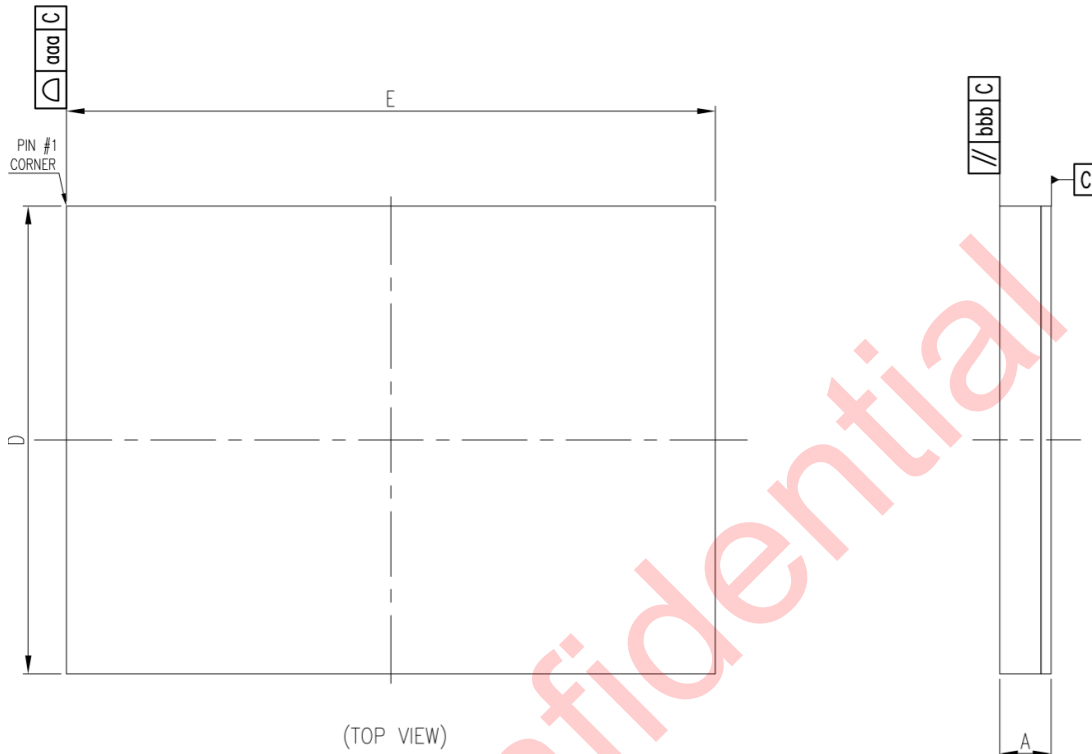

SYMBOL	DIMENSION IN MM			DIMENSION IN INCH		
	MIN.	NOM.	MAX.	MIN.	NOM.	MAX.
A	0.94	0.99	1.04	0.037	0.039	0.041
b	0.70	0.75	0.80	0.028	0.030	0.031
D	8.90	9.00	9.10	0.350	0.354	0.358
E	12.40	12.50	12.60	0.488	0.492	0.496
D2	3.10	3.20	3.30	0.122	0.126	0.130
E2	2.20	2.30	2.40	0.087	0.091	0.094
L	0.80	0.85	0.90	0.031	0.033	0.035
e	1.27 BSC.			0.050 BSC.		
JEDEC	MO-222(REF.)/MM					
aaa	0.10					
bbb	0.10					
ddd	---					
eee	0.15					
fff	0.05					
N	SE (mm)	SD (mm)	E1 (mm)	D1 (mm)		
8	5.80 BSC.	0.635 BSC.	11.625 BSC.	3.81 BSC.		

10. Reference Design

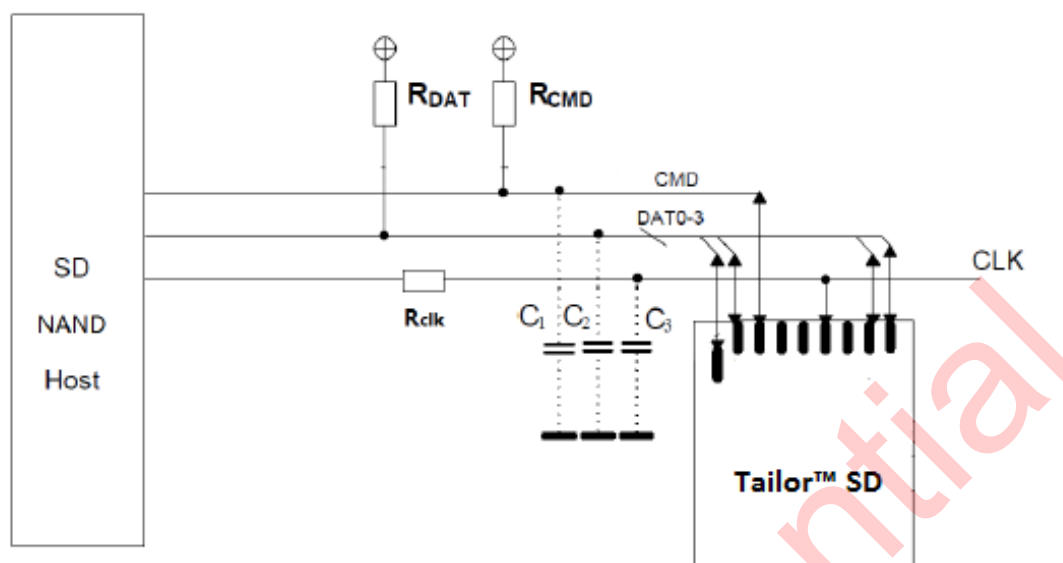

R_{DAT} and R_{CMD} (10K~100 k Ω) are pull-up resistors protecting the CMD and the DAT lines against bus floating when Nano SD NAND is in a high-impedance mode.

The host shall pull-up all DAT0-3 lines by R_{DAT} , even if the host uses the Nano SD NAND as 1 bit mode-only in SD mode. It is recommended to have 2.2uF capacitance on VDD.

R_{clk} reference 0~120 Ω