



# **CS5213 Datasheet**

## **HDMI to VGA Convertor**

---

[www.angerei.com](http://www.angerei.com) TEL13699758578 QQ1176845380

---

## Contents

---

<b>1</b>	<b>Introduction.....</b>	<b>5</b>
<b>2</b>	<b>Features.....</b>	<b>6</b>
<b>3</b>	<b>Pin Definition.....</b>	<b>7</b>
	3.1 Pin Assignments.....	7
	3.2 Pin Description.....	7
<b>4</b>	<b>Interfaces and Capability.....</b>	<b>9</b>
	4.1 HDMI Input .....	9
	4.2 HDCP(Optional).....	9
	4.3 Analog VGA output .....	9
<b>5</b>	<b>Electrical Specifications .....</b>	<b>11</b>
	5.1 Absolute Maximum Conditions .....	11
	5.2 Operating Conditions.....	11
	5.3 Electrical Specification .....	11
	5.4 CS5213 Power Consumption .....	13
<b>6</b>	<b>Package Specification.....</b>	<b>14</b>
<b>7</b>	<b>Ordering Information.....</b>	<b>15</b>
<b>8</b>	<b>Revision History.....</b>	<b>16</b>

---

## List of Figures

---

Figure 1-1 CS5213 Block Diagram .....	5
Figure 3-1 CS5213 Pin Layout.....	7
Figure 6-1 CS5213 Package Outline (QFN32 Leads 4x4mm) .....	14

---

## List of Tables

---

<i>Table 3-1 CS5213 Pin Definitions</i>	7
<i>Table 4-1 Supported Popular Timing/ Resolution</i>	10
<i>Table 5-1 Absolute Maximum Conditions</i>	11
<i>Table 5-2 Normal Operating Conditions</i>	11
<i>Table 5-3 DC Electrical Specification</i>	11
<i>Table 5-4 AC Electrical Specification</i>	12
<i>Table 5-5 Audio Electrical Characteristics</i>	12
<i>Table 5-6 CS5213 Typical Power Consumption</i>	13
<i>Table 6-1 Package Dimension</i>	14
<i>Table 7-1 CS5213 Ordering Information</i>	15
<i>Table 8-1 Document Revision History</i>	16

# 1 Introduction

The Capstone CS5213 HDMI to VGA converter combines a HDMI input interface and an analog RGB DAC output. With support and on-chip Audio DAC, it saves cost and optimizes board space. The embedded MCU is based on an industrial standard 8051 core.

The CS5213 is suitable for multiple market segments and display applications, such as laptop, motherboard, desktop, dongle, and docking system.

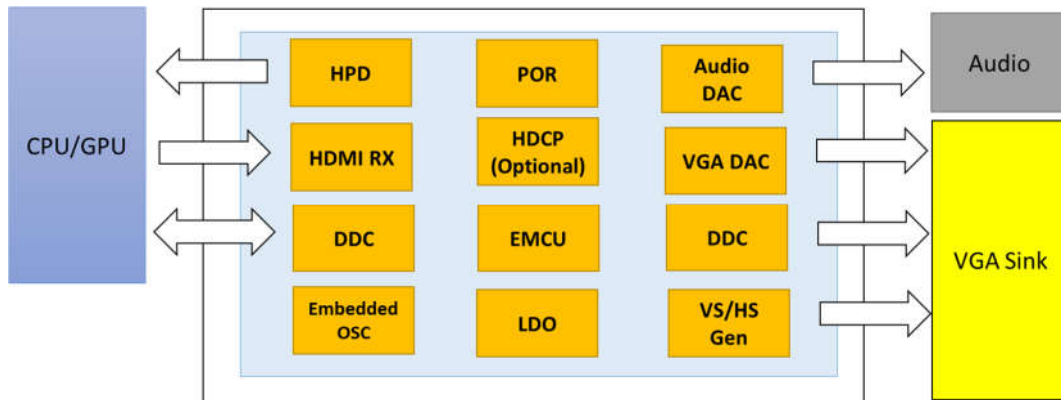

Figure 1-1 CS5213 Block Diagram

---

## 2 Features

---

### General

- HDMI 1.4 compliant receiver
- VGA output interface, DAC speed up to ~200-MHz Pixel rate, 8-bit
- Video resolution support up to 1920x1200@60 and 1920X1080@60Hz
- Embedded oscillator and there's no need for external crystal
- Embedded linear dropout regulator (LDO)
- Embedded MCU
- On-chip HDCP Engine Which is compliant with HDCP 1.4 Specification (Optional)
- Integrated on-chip HDCP 1.4 Keys (Optional)
- Embedded EDID (CS5213 will response EDID if terminal device doesn't have it)
- Support EEPROM Free mode by using the internal pre-blew ROM
- Support Auto Power Saving mode
- VGA Connection detection supported
- Internal power-on-reset (POR)
- Dual Channel 16-bit resolution sigma-delta DAC
- Support Audio Sampling Frequently (Fs): up to 48KHz
- I2C Slave interface and HDMI DDC interface are available for debug and firmware update.
- QFN32 4x4 package

### HDMI Digital Input

- HDMI 1.4 compliant
- Built-in high-performance adaptive equalizer
- Support Hot Plug Detection

### VGA Output Interface

- Triple 8-bit DAC (Digital-to-Analog Converter) with clock up to 200-MHz
- Video resolution support up to 1920x1200@60 and 1920X1080@60Hz
- Embedded V-sync/ H-sync 5V buffer
- HBM 4-KV for VGA connector pins
- VESA VSIS v1r2 compliant

### Embedded MCU

- Industrial standard 8051 core
- Support I2C Master and Slave up to 400-KHz.

### Power & Technology

- Single 5V power supply
- Ultralow standby power < 100uW

### 3 Pin Definition

#### 3.1 Pin Assignments

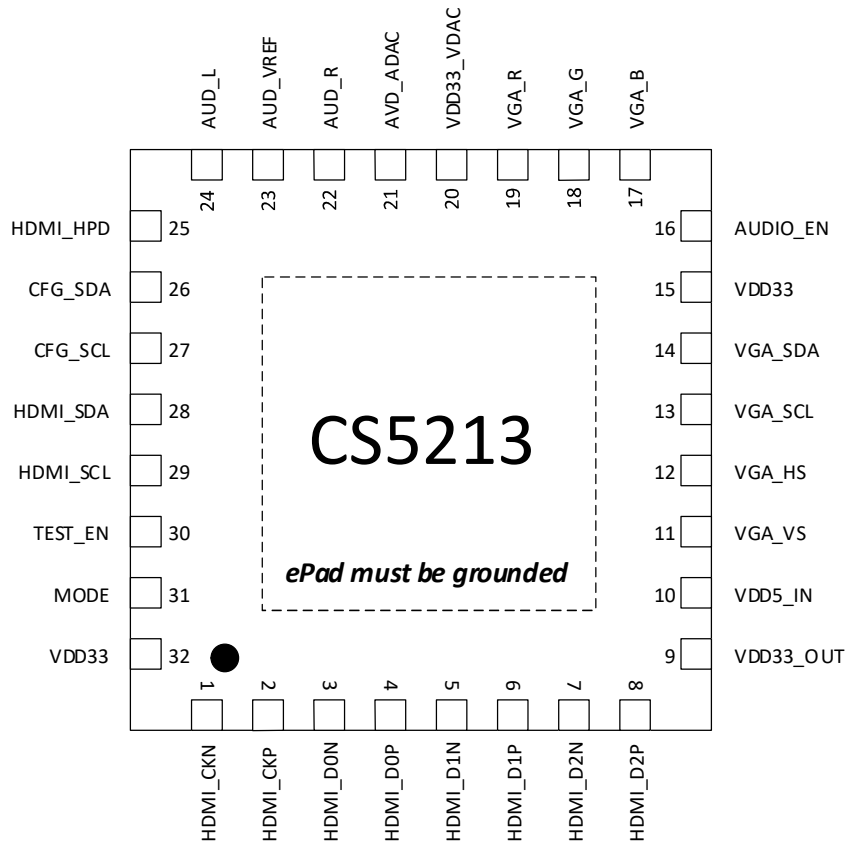

Figure 3-1 CS5213 Pin Layout

#### 3.2 Pin Description

Table 3-1 CS5213 Pin Definitions

Pin #	Description	Type	PU/PD	Note
1	HDMI_CKN	I	-	HDMI clock differential pair N input
2	HDMI_CKP	I	-	HDMI clock differential pair P input
3	HDMI_D0N	I	-	HDMI data channel 0 different pair N input
4	HDMI_D0P	I	-	HDMI data channel 0 different pair P input
5	HDMI_D1N	I	-	HDMI data channel 1 different pair N input

Pin #	Description	Type	PU/PD	Note
6	HDMI_D1P	I	-	HDMI data channel 1 different pair P input
7	HDMI_D2N	I	-	HDMI data channel 2 different pair N input
8	HDMI_D2P	I	-	HDMI data channel 2 different pair P input
9	VDD33_OUT	P	-	3.3V power output
10	VDD5_IN	P	-	5V power input
11	VGA_VS	O	-	VGA vertical sync output
12	VGA_HS	O	-	VGA horizontal sync output
13	VGA_SCL	I/O	-	VGA DDC clock
14	VGA_SDA	I/O	-	VGA DDC data
15	VDD33	P	-	3.3V power input
16	AUDIO_EN	I	PD	Audio DAC control, Internal has a weakness pull-down resistor. High = enable Low or NC = disable
17	VGA_B	O	-	VGA Blue channel output
18	VGA_G	O	-	VGA Green channel output
19	VGA_R	O	-	VGA Red channel output
20	VDD33_VDAC	P	-	3.3V Video DAC power input, connect with VDD33_OUT
21	AVD_ADAC	P	-	3.3V Audio DAC power input, connect with VDD33_OUT
22	AUD_R	O	-	Audio DAC right channel headphone output
23	AUD_VREF	O	-	Audio DAC Internal voltage reference, tie 10uF in parallel with a 0.1uF ceramic capacitor to analog ground.
24	AUD_L	O	-	Audio DAC left channel headphone output
25	HDMI_HPD	I/O	PD	HDMI Hot Plug detect output
26	CFG_SDA	I/O	-	I2C slave DATA pin
27	CFG_SCL	I/O	-	I2C slave CLOCK pin
28	HDMI_SDA	I/O	-	HDMI DDC data
29	HDMI_SCL	I/O	PU	HDMI DDC clock
30	TEST_EN	I	PD	1: Test mode. 0: Normal mode
31	MODE	I	PU	1: Flash mode. 0: Reserved (Don't pull down)
32	VDD33	P	-	3.3V power input



---

## 4 Interfaces and Capability

---

### 4.1 HDMI Input

The HDMI input is compliant with the HDMI 1.4b standard. It supports HDCP(Optional) 1.4 content protection standard.

The DDC\_SCL and DDC\_SDA signals are used to access EDID. Because of pull-up resistors on these signals has been integrated into Chip, so there is no need external pull-up resistor anymore.

### 4.2 HDCP(Optional)

The CS5213 supports HDCP 1.4 on the output video link with an embedded HDCP key. The Digital Rights Management (DRM) policy of the operating system running on the source application processor decides whether or not to enable HDCP on the link, depending on the content.

The HDCP(Optional) authentication is performed before the audio-video transmission. The HDCP authentication and encryption can be performed by the hardware HDCP module. Pre-programmed HDCP keys and Key Selector Value (KSV) stored in the internal memory are used in the HDCP process.

### 4.3 Analog VGA output

CS5213 integrates triple 8bit-250MHz-DAC (Digital-to-Analog Converters), with each DAC assigned for each color, R (red), G (green), and B (blue). The Analog VGA interface of CS5213 is compliant with the VESA VSIS v1r2. Real-time Hot plug detection mechanism is also integrated into CS5213.

The most popular video formats supported by CS5213 are shown in the following Table 4 1. However, the formats supported by CS5213 are not limited to this table. Those formats with (a) the data transmission bandwidth lower than the maximal bandwidth, the pixel frequency slower than the maximal DAC speed 200-MHz can also be supported by CS5213.

**Table 4-1 Supported Popular Timing/ Resolution**

Resolution	Refresh Rate (Hz)	Horizontal Freq. (kHz)	Pixel Freq. (MHz)	Standard Type	Ori. Document	Date
800 x 600	60	37.9	40.000	VESA Guidelines	VG900602	8/6/90
	72	48.1	50.000	VESA Standard	VS900603A	8/6/90
	75	46.9	49.500	VESA Standard	VDMT75HZ	10/4/93
	85	53.7	56.250	VESA Standard	VDMTPROP	3/1/96
848 x 480	60	31.0	33.750	VESA Standard	AddDMT	3/4/03
1024 x 768	43	35.5	44.900	Industry Standard		
	60	48.4	65.000	VESA Guidelines	VG901101A	9/10/91
	70	56.5	75.000	VESA Standard	VS910801-2	8/9/91
	75	60.0	78.750	VESA Standard	VDMT75HZ	10/4/93
1152 x 864	75	67.5	108.000	VESA Standard	VDMTPROP	3/1/96
1280 x 720	60	45.0	74.250	CEA Standard	CEA -861	
1280 x 768	60	47.4	68.250	CVT Red. Blanking	AddDMT	3/4/03
	60	47.8	79.500	CVT	AddDMT	3/4/03
	75	60.3	102.250	CVT	AddDMT	3/4/03
	85	68.6	117.500	CVT	AddDMT	3/4/03
1280 x 800	60	49.3	71.000	CVT Red. Blanking	CVT1.0 2MA-R	5/1/07
	60	49.7	83.500	CVT	CVT 1.02MA	5/1/07
	75	62.8	106.500	CVT	CVT 1.02MA	5/1/07
	85	71.6	122.500	CVT	CVT 1.02MA	5/1/07
1280 x 960	60	60.0	108.000	VESA Standard	VDMTPROP	3/1/96
	85	85.9	148.500	VESA Standard	VDMTPROP	3/1/96
1280 x 1024	60	64.0	108.000	VESA Standard	VDMTREV	12/18/96
	75	80.0	135.000	VESA Standard	VDMT75HZ	10/4/93
	85	91.1	157.500	VESA Standard	VDMTPROP	3/1/96
1360x768	60	48.0	72.000	VESA Standard	DMT Update	11/30/07
	60	47.7	85.500	VESA Standard	AddDMT	3/4/03
	60	47.7	85.500	VESA Standard	DMT Update	11/30/07
1400 x 1050	60	64.7	101.000	CVT Red. Blanking	AddDMT	5/13/03
	60	65.3	121.750	CVT	AddDMT	3/4/03
	75	82.3	156.000	CVT	AddDMT	3/4/03
	85	93.9	179.500	CVT	AddDMT	3/4/03
1440 x 900	60	55.5	88.750	CVT Red. Blanking	CVT1.30MA-R	7/14/04
	60	55.9	106.500	CVT	CVT1.30MA-R	7/14/04
	75	70.6	136.750	CVT	CVT1.30MA-R	7/14/04
	85	80.4	157.000	CVT	CVT1.30MA-R	7/14/04
1600 x 900	60	60.0	108.000	VESA Standard	VDMTREV	11/17/08
1600 x 1200	60	75.0	162.000	VESA Standard	VDMTREV	12/18/96
	65	81.3	175.500	VESA Standard	VDMTREV	12/18/96
	70	87.5	189.000	VESA Standard	VDMTREV	12/18/96
	75	93.75	202.5	VESA Standard	VDMTREV	12/18/96
1680 x 1050	60	64.7	119.000	CVT Red. Blanking	CVT1.76MA-R	7/14 /04
	60	65.3	146.250	CVT	CVT1.76MA-R	7/14 /04
	75	82.3	187.000	CVT	CVT1.76MA-R	7/14 /04
1920 x 1080	60	67.5	148.500	CEA Standard	CEA -861	-
1920 x 1200	60	74.0	154.000	CVT Red. Blanking	AddDMT	3/4/03
	60	74.6	193.250	CVT	AddDMT	3/4/03
1920 x 1440	60	88.822	184.750	CVT Red. Blanking	CVT2.76M3-R	-
2048 x 1152	60	70.992	156.750	CVT Red. Blanking	VDMT REV	11/17 /08
2048 x 1536	60	94.769	209.250	CVT Red. Blanking	CVT3.15M3-R	-
2560 x 1080	60	66.636	181.250	Cinema 21:9 Aspect Ratio	N/A	N/A

## 5 Electrical Specifications

### 5.1 Absolute Maximum Conditions

Permanent damage may occur if absolute maximum conditions are violated. Refer to Section 5.2 for functional operating limits.

**Table 5-1 Absolute Maximum Conditions**

Symbol	Parameter	Min	Typ	Max	Unit
VDD5_IN	5V Power Input	-0.3	—	6	V
VDD33	3.3V power input	-0.3	—	3.96	V
VDD33_VDAC	3.3V Video DAC power input	-0.3	—	3.96	V
AVD_ADAC	3.3V Audio DAC power input	-0.3	—	3.96	V
T <sub>A</sub>	Junction temperature	-40	—	125	°C
Q <sub>JA</sub>	Storage temperature <sup>1</sup>	-65	—	150	°C
ESD <sub>HBM</sub>	ESD protection (Human body model)	—	—	±8	KV
ESD <sub>CDM</sub>	ESD protection (Charge Device model)	—	—	700	V

1. Max 260°C can be guaranteed with max 8 sec soldering time.

### 5.2 Operating Conditions

**Table 5-2 Normal Operating Conditions**

Symbol	Parameter	Min	Typ	Max	Unit
VDD33_OUT	3.3V LDO output	3.0	3.3	3.6	V
VDD5_IN	5V Power Input	4.75	5	5.25	V
VDD33	3.3V power input	3.0	3.3	3.6	V
VDD33_VDAC	3.3V Video DAC power input	3.0	3.3	3.6	V
AVD_ADAC	3.3V Audio DAC power input	3.0	3.3	3.6	V
T <sub>A</sub>	Ambient temperature	-10	—	70	°C
Q <sub>JA</sub>	Package thermal resistance, no air flow	—	39.3	—	°C/W

### 5.3 Electrical Specification

**Table 5-3 DC Electrical Specification**

Symbol	Parameter	For 3.3V I/O		
		Min	Typ	Max
V <sub>il</sub> (V)	Input low voltage	—	—	0.8
V <sub>ih</sub> (V)	Input high Voltage	2.0	—	—

Symbol	Parameter	For 3.3V I/O		
		Min	Typ	Max
V <sub>ol</sub> (V)	Output low voltage	0	—	0.4
V <sub>oh</sub> (V)	Output high voltage <sup>1</sup>	2.4	—	—
I <sub>in</sub> (uA)	Input leakage current	-10	—	+10
I <sub>hiz</sub> (uA)	Output tri-state leakage current	-10	—	+10

**Table 5-4 AC Electrical Specification**

Symbol	Description	Min	Typ	Max	Unit
T <sub>DPS</sub>	Intra-Pair Differential Input Skew			0.4	T <sub>bit</sub>
T <sub>CCS</sub>	Channel to Channel Differential Input Skew			1.0	T <sub>pixel</sub>
T <sub>JIT</sub>	Differential Input Clock Jitter Tolerance			0.3	T <sub>bit</sub>
F <sub>RXC</sub>	TMDS Clock Frequency	25		200	MHz

**Table 5-5 Audio Electrical Characteristics**

Symbol	Description	Load(Ω)	Min	Typ	Max	Unit
SNR	Signal to Noise Ratio	1K	--	-73	--	dB
DR	Dynamic Range	1K	--	-73	--	dB
THD+N	Total Harmonic Distortion	1K	--	-60	--	dB
ICI	Inter-channel isolation	1K	--	-75	--	dB

## 5.4 CS5213 Power Consumption

Different applications would result in different power consumptions of CS5213. For example, whether to adopt the embedded oscillator, and how fast of the video clock frequency are all definitely the key factors of the power consumption of CS5213. The following tables show the reference power consumption of CS5213 in several different application conditions.

**Table 5-6 CS5213 Typical Power Consumption**

Active Resolution / Standby	Min	Typ	Max	Unit
800x600x60 (74.25-MHz)	-	TBD	-	mW
1024x768x60 (103-MHz)	-	TBD	-	mW
1920x1080x60 (148-MHz)	-	TBD	-	mW
Stand-by mode	-	-	TBD	uW

Note: In practice, the measured power consumption might be slightly different from the tables above due to the different video content and the different measurement equipment

## 6 Package Specification

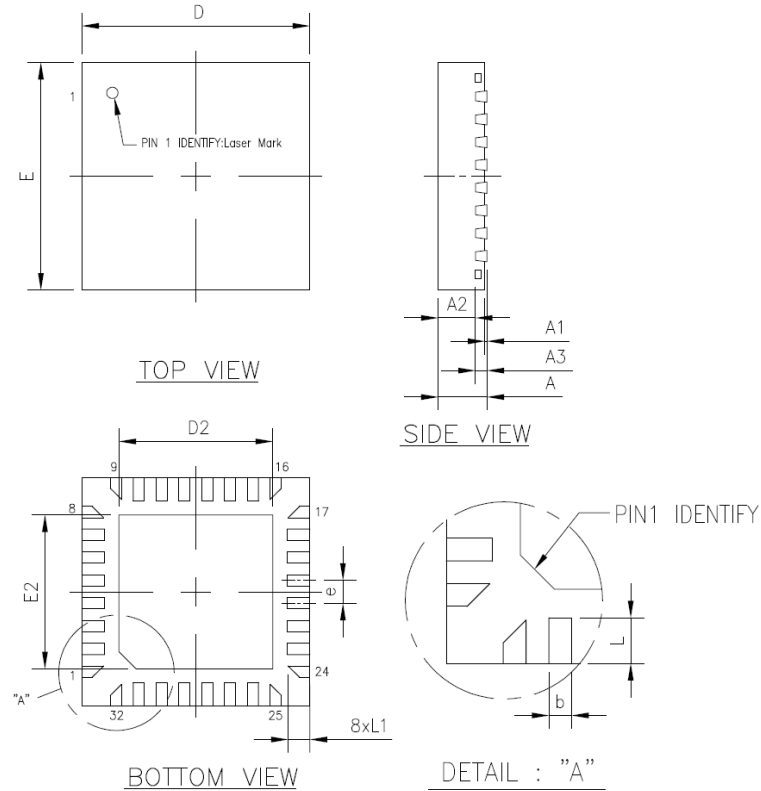

Figure 6-1 CS5213 Package Outline (QFN32 Leads 4x4mm)

Table 6-1 Package Dimension

Symbol	Dimension in mm			Dimension in inch		
	Min	Normal	Max	Min	Normal	Max
A	0.80	0.85	0.90	0.031	0.033	0.035
A1	0.00	0.02	0.05	0.000	0.001	0.002
A2	—	0.65	0.70	—	0.026	0.028
A3		0.20 REF			0.008 REF	
b	0.15	0.20	0.25	0.006	0.080	0.010
D/E		4.00 BSC			0.157 BSC	
D2/E2	2.55	2.70	2.85	0.096	0.106	0.116
e		0.40 BSC			0.016 BSC	
L	0.30	0.40	0.50	0.012	0.016	0.020
L1	0.282	0.382	0.482	0.011	0.015	0.019

---

## 7 Ordering Information

---

The CS5213 can be ordered using the part numbers in Table 7-1. Please consult sales for further details.

**Table 7-1 CS5213 Ordering Information**

Part No.	Description	Temperature Range	Packing Type
CS5213	32 Pin (QFN) Lead-free package	Commercial: 0 to 70 degree C	Tape

## 8 Revision History

---

Table 8-1 Document Revision History

Revision	Date	Changes
Release 1	April 2020	Initial version
Release 2	May 2020	Update
Release 3	June 2020	Update Pin Assignments and Pin Description