

AP15N10K
N-Channel Power MOSFET

100V N-CHANNEL ENHANCEMENT MODE POWER MOSFET

Features

- 100V, 14.6A
- $R_{DS(ON)} = 100m\Omega$ (max.) @ $V_{GS} = 10V, I_D = 5A$
- Super Low Gate Charge
- Excellent CdV/dt effect decline
- Advanced high cell density Trench technology
- RoHS Compliant & Halogen-Free

Application

- Synchronous buck converter applications.

Package



TO-252

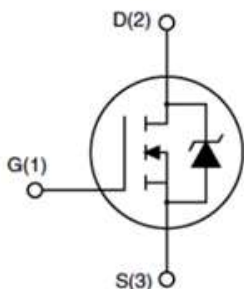

Absolute Maximum Ratings $T_C=25^\circ C$ unless otherwise specified

Symbol	Parameter	Max.	Units	
V_{DS}	Drain-Source Voltage	100	V	
V_{GS}	Gate-Source Voltage	± 20	V	
I_D	Continuous Drain Current, $V_{GS} @ 10V_{no}$ ^{note1,6}	$T_C = 25^\circ C$	14.6	A
		$T_C = 100^\circ C$	10	A
I_{DM}	Pulsed Drain Current ^{note2}	25	A	
P_D	Power Dissipation ^{note4}	$T_C = 25^\circ C$	30	W
E_{AS}	Single Pulsed Avalanche Energy ^{note3}	0.8	mJ	
$R_{\theta JA}$	Thermal Resistance, Junction to Case ^{note1}	3	$^\circ C/W$	
T_J, T_{STG}	Operating and Storage Temperature Range	-55 to +150	$^\circ C$	

AP15N10K

N-Channel Power MOSFET

Electrical Characteristics $T_C=25^\circ\text{C}$ unless otherwise specified

Symbol	Parameter	Test Condition	Min.	Typ.	Max.	Units
Off Characteristics						
BV_{DSS}	Drain-Source Breakdown Voltage	$V_{GS} = 0V, I_D = 250\mu A$	100	-	-	V
I_{DSS}	Drain-Source Leakage Current	$V_{DS} = 80V, V_{GS} = 0V$	-	-	10	μA
		$V_{DS} = 80V, T_C = 55^\circ\text{C}$	-	-	100	μA
I_{GSS}	Gate to Body Leakage Current	$V_{DS} = 0V, V_{GS} = \pm 20V$	-	-	± 100	nA
On Characteristics						
$V_{GS(th)}$	Gate Threshold Voltage	$V_{DS} = V_{GS}, I_D = 250\mu A$	1.2	-	2.9	V
$R_{DS(on)}$	Static Drain-Source On-Resistance ^{note2}	$V_{GS} = 10V, I_D = 5A$	-	85	100	m Ω
		$V_{GS} = 4.5V, I_D = 3A$	-	90	110	m Ω
g_{FS}	Forward Transconductance	$V_{DS} = 5V, I_D = 5A$	-	14	-	S
Dynamic Characteristics						
C_{iss}	Input Capacitance	$V_{DS} = 15V, V_{GS} = 0V,$ $f = 1.0\text{MHz}$	-	450	-	pF
C_{oss}	Output Capacitance		-	55	-	pF
C_{rss}	Reverse Transfer Capacitance		-	16	-	pF
Q_g	Total Gate Charge	$V_{DS} = 50V, I_D = 5A,$ $V_{GS} = 10V$	-	11.9	-	nC
Q_{gs}	Gate-Source Charge		-	2.8	-	nC
Q_{gd}	Gate-Drain("Miller") Charge		-	1.7	-	nC
Switching Characteristics						
$t_{d(on)}$	Turn-On Delay Time	$V_{DD} = 50V, I_D = 5A,$ $R_G = 3.3\Omega, V_{GS} = 10V$	-	3.8	-	ns
t_r	Turn-On Rise Time		-	25.8	-	ns
$t_{d(off)}$	Turn-Off Delay Time		-	16	-	ns
t_f	Turn-Off Fall Time		-	8.8	-	ns
Drain-Source Diode Characteristics and Maximum Ratings						
I_S	Maximum Continuous Drain to Source Diode Forward Current ^{note1,5}		-	-	14.6	A
I_{SM}	Maximum Pulsed Drain to Source Diode Forward Current ^{note2,5}		-	-	25	A
V_{SD} ^{note2}	Drain to Source Diode Forward Voltage	$V_{GS} = 0V, I_S = 1A$	-	-	1.2	V

Note :

- The data tested by surface mounted on a 1 inch² FR-4 board with 2OZ copper.
- The data tested by pulsed , pulse width $\leq 300\mu s$, duty cycle $\leq 2\%$
- The EAS data shows Max. rating . The test condition is $V_{DD}=25V, V_{GS}=10V, L=0.1mH, I_{AS}=50A$
- The power dissipation is limited by 150°C junction temperature
- The data is theoretically the same as I_D and I_{DM} , in real applications , should be limited by total power dissipation.
- Package limitation current is 85A.

Typical Performance Characteristics

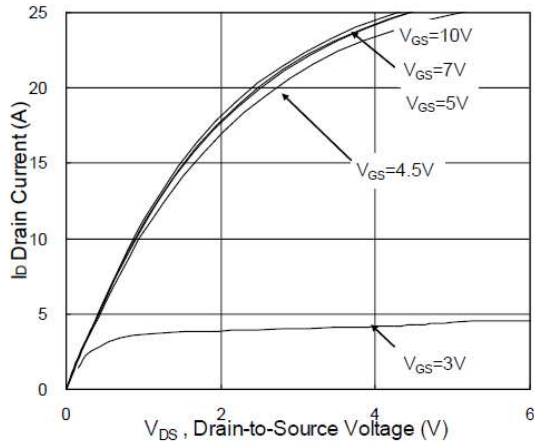

Figure 1. Output Characteristics

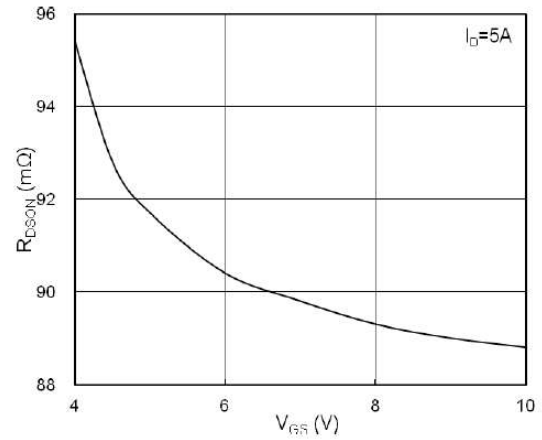

Figure 2. On Resistance vs. Gate-Source Voltage

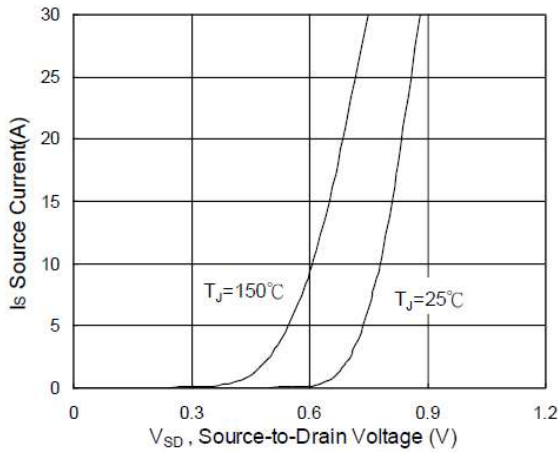

Figure 3. Body Diode Forward Voltage vs. Source Current and Temperature

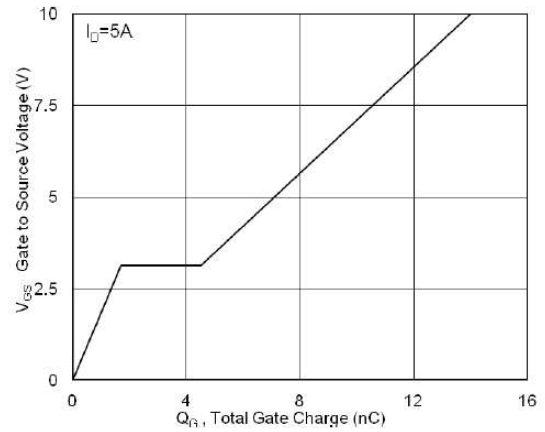

Figure 4. Gate Charge Characteristics

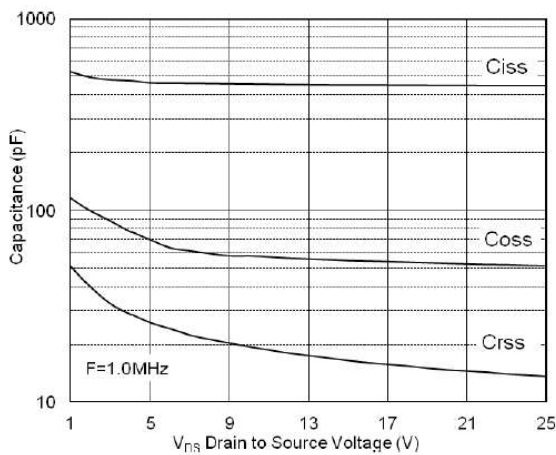

Figure 5. Capacitance Characteristics

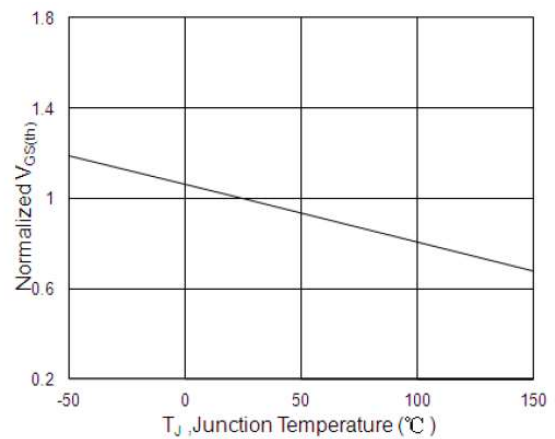

Figure 6. Normalized Threshold Voltage vs. Junction Temperature

AP15N10K
N-Channel Power MOSFET

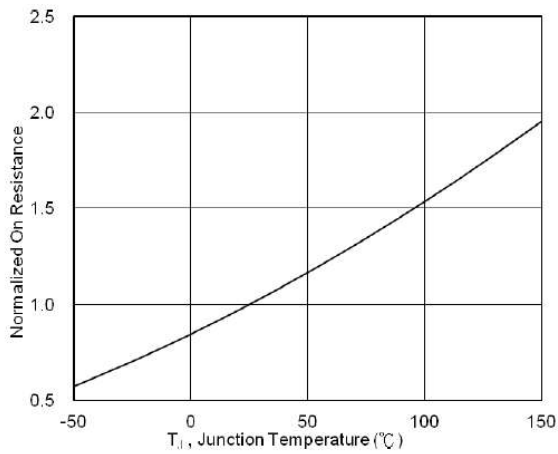

Figure 7. N Normalized On Resistance vs. Junction Temperature

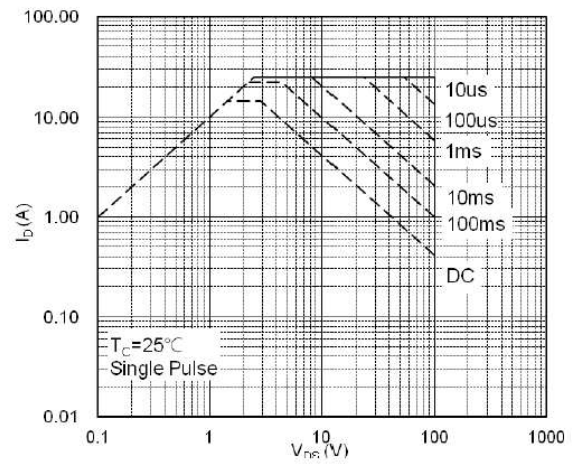

Figure 8. Maximum Safe Operating Area

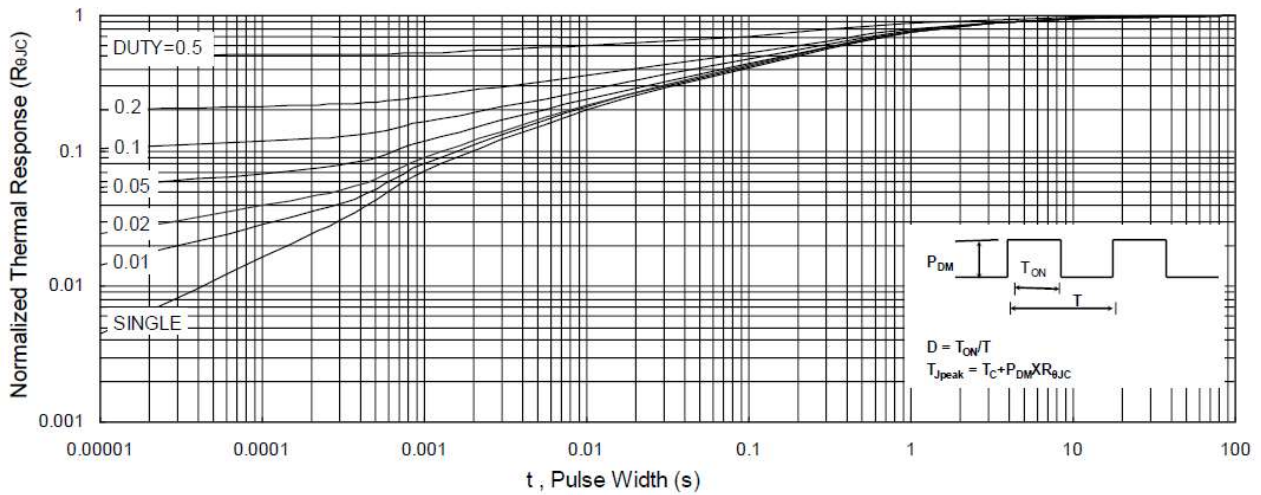

Figure 9. Effective Transient Thermal Impedance

AP15N10
N-Channel Power MOSFET

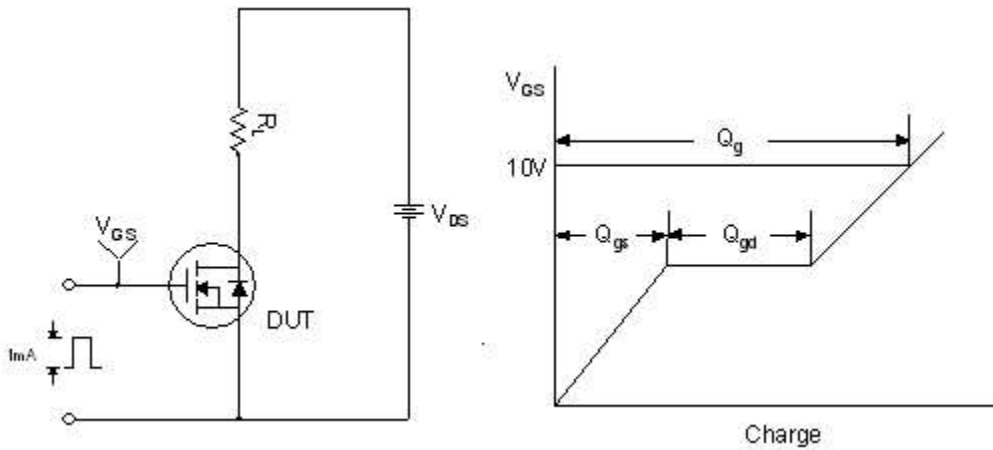

Figure 10. Gate Charge Test Circuit & Waveform

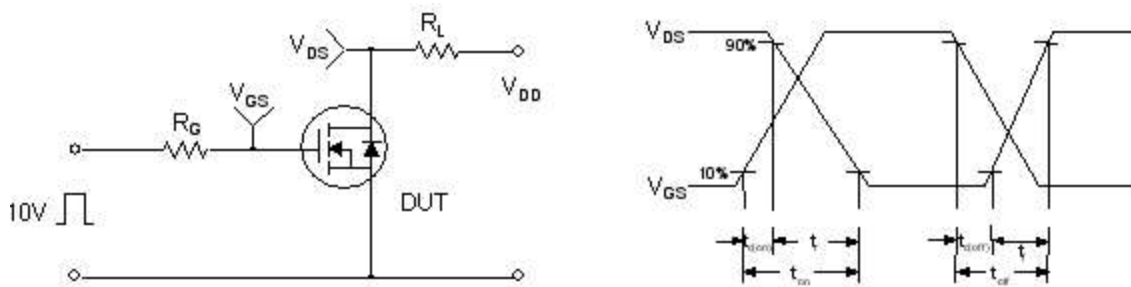

Figure 11. Resistive Switching Test Circuit & Waveforms

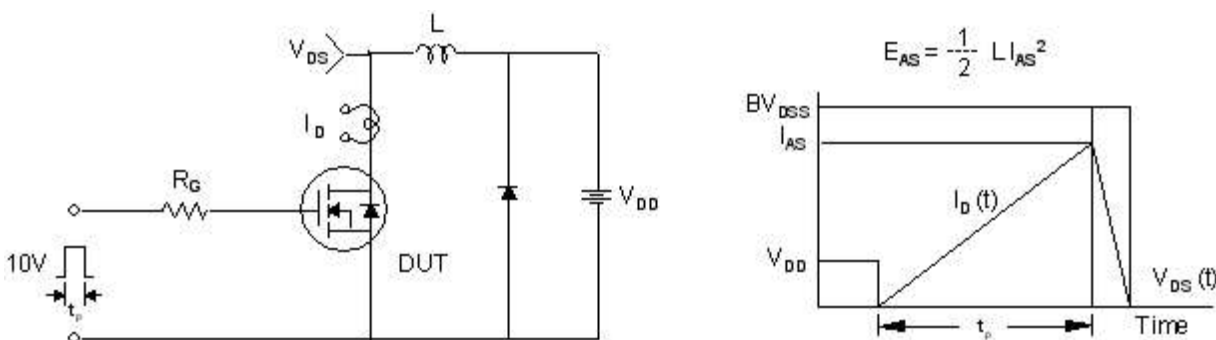

Figure 12. Unclamped Inductive Switching Test Circuit & Waveforms

AP15N10K
N-Channel Power MOSFET

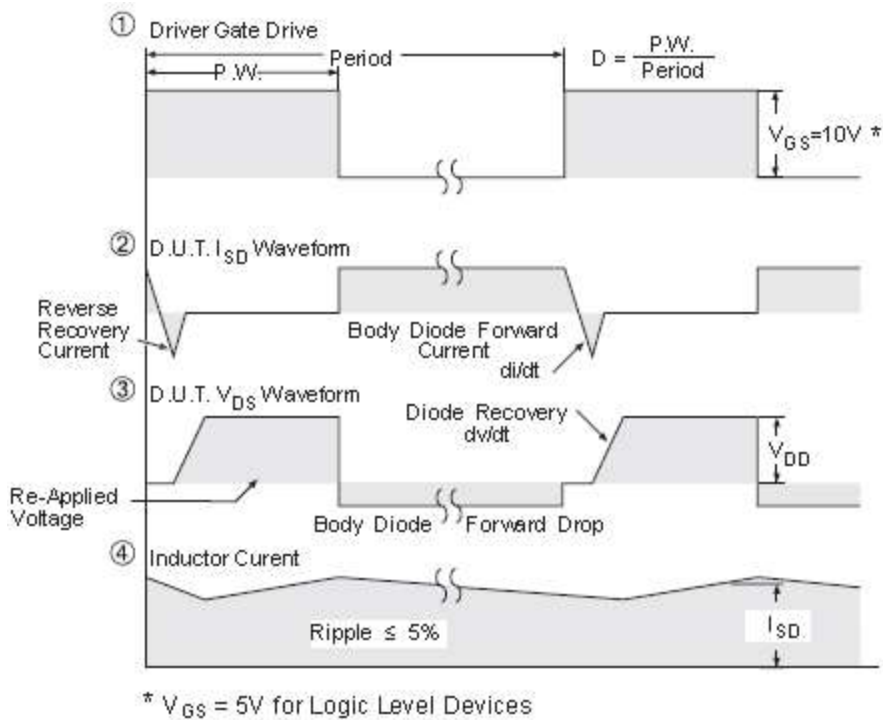
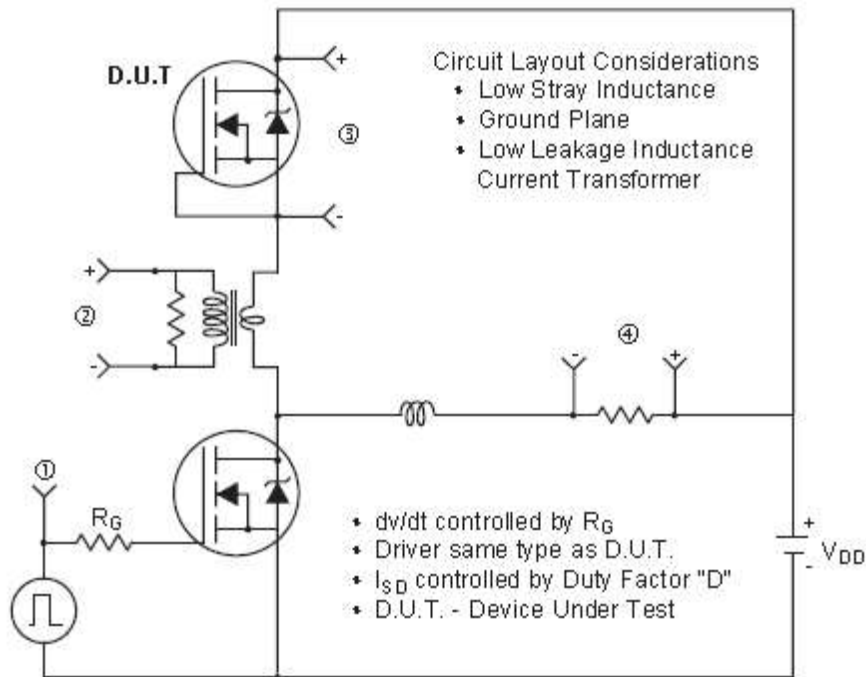

Figure 13. Peak Diode Recovery dv/dt Test Circuit & Waveforms (For N-channel)