

AP30H80K

N-Channel Power MOSFET

Features

- 30V,75A
- $R_{DS(ON)}=4.8m\Omega$ (Typ.) @ $V_{GS}=10V$
- $R_{DS(ON)}=6.5m\Omega$ (Typ.) @ $V_{GS}=4.5V$
- Advanced Trench Technology
- Provide Excellent $R_{DS(ON)}$ and Low Gate Charge

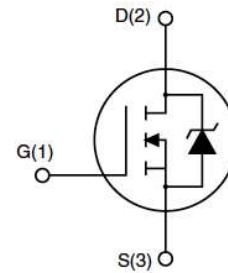

Application

- Load Switch
- PWM Application

Package



Absolute Maximum Ratings (T_c=25°C unless otherwise specified)

Symbol	Parameter	Max.	Units	
V _{DSS}	Drain-Source Voltage	30	V	
V _{GSS}	Gate-Source Voltage	±20	V	
I _D	Continuous Drain Current	T _C = 25°C	75	A
		T _C = 100°C	50	A
I _{DM}	Pulsed Drain Current ^{note1}	300	A	
E _{AS}	Single Pulsed Avalanche Energy ^{note2}	88	mJ	
P _D	Power Dissipation	T _C = 25°C	75	W
R _{θJC}	Thermal Resistance, Junction to Case	2	°C/W	
R _{θJA}	Thermal Resistance, Junction to Ambient	65		
T _J , T _{STG}	Operating and Storage Temperature Range	-55 to +175	°C	

AP30H80K
N-Channel Power MOSFET
Electrical Characteristics ($T_C=25^\circ\text{C}$ unless otherwise specified)

Symbol	Parameter	Test Condition	Min.	Typ.	Max.	Units
Off Characteristic						
$V_{(BR)DSS}$	Drain-Source Breakdown Voltage	$V_{GS}=0V, I_D=250\mu A$	30	-	-	V
I_{DSS}	Zero Gate Voltage Drain Current	$V_{DS}=30V, V_{GS}=0V,$ $T_J=25^\circ\text{C}$	-	-	1	uA
		$V_{DS}=24V, V_{GS}=0V,$ $T_J=125^\circ\text{C}$	-	-	10	
I_{GSS}	Gate to Body Leakage Current	$V_{DS}=0V, V_{GS}=\pm 20V$	-	-	± 100	nA
On Characteristics						
$V_{GS(th)}$	Gate Threshold Voltage	$V_{DS}=V_{GS}, I_D=250\mu A$	1.0	1.6	2.5	V
$R_{DS(on)}$	Static Drain-Source on-Resistance <small>note3</small>	$V_{GS}=10V, I_D=20A$	-	4.8	6	m Ω
		$V_{GS}=4.5V, I_D=10A$	-	6.5	9	
g_{FS}	Forward Transconductance	$V_{DS}=5V, I_D=10A$	-	20	-	S
Dynamic Characteristics						
C_{iss}	Input Capacitance	$V_{DS}=25V, V_{GS}=0V,$ $f=1.0\text{MHz}$	-	1160	-	pF
C_{oss}	Output Capacitance		-	200	-	pF
C_{rSS}	Reverse Transfer Capacitance		-	180	-	pF
Q_g	Total Gate Charge	$V_{DS}=15V, I_D=20A,$ $V_{GS}=4.5V$	-	11.1	-	nC
Q_{gs}	Gate-Source Charge		-	1.85	-	nC
Q_{gd}	Gate-Drain("Miller") Charge		-	6.8	-	nC
Switching Characteristics						
$t_{d(on)}$	Turn-on Delay Time	$V_{DS}=15V,$ $I_D=15A, R_G=3.3\Omega,$ $V_{GS}=10V$	-	7.5	-	ns
t_r	Turn-on Rise Time		-	14.5	-	ns
$t_{d(off)}$	Turn-off Delay Time		-	35.2	-	ns
t_f	Turn-off Fall Time		-	9.6	-	ns
Drain-Source Diode Characteristics and Maximum Ratings						
I_S	Maximum Continuous Drain to Source Diode Forward Current		-	-	75	A
I_{SM}	Maximum Pulsed Drain to Source Diode Forward Current		-	-	300	A
V_{SD}	Drain to Source Diode Forward Voltage	$V_{GS}=0V, I_S=30A$	-	-	1.2	V
t_{rr}	Body Diode Reverse Recovery Time	$I_S=30A, di/dt=100A/\mu s$	-	32	-	ns
Q_{rr}	Body Diode Reverse Recovery Charge		-	12	-	nC

Notes: 1. Repetitive Rating: Pulse Width Limited by Maximum Junction Temperature

 2. EAS condition: $T_J=25^\circ\text{C}, V_{DD}=25V, V_{GS}=10V, L=0.1\text{mH}, I_{AS}=42A, R_G=25\Omega$

 3. Pulse Test: Pulse Width $\leq 300\mu s$, Duty Cycle $\leq 2\%$

AP30H80K
N-Channel Power MOSFET

Typical Performance Characteristics

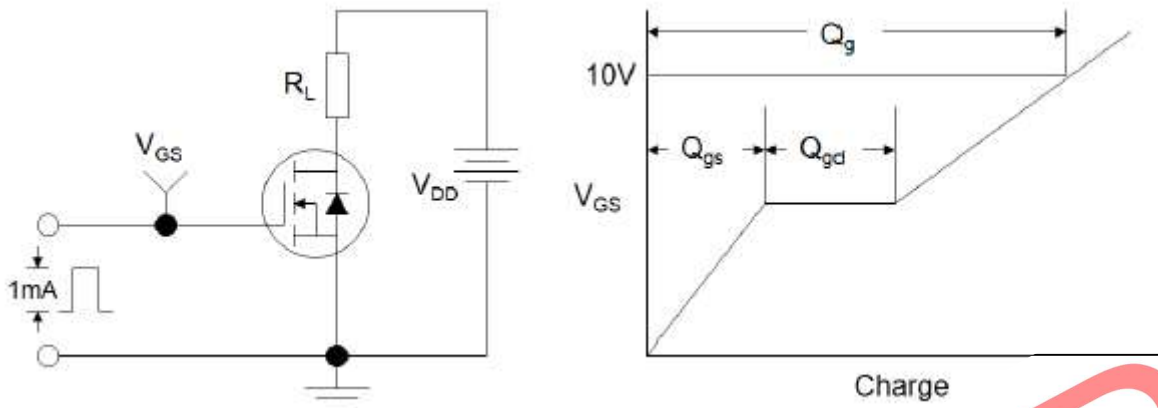

Figure1:Gate Charge Test Circuit & Waveform

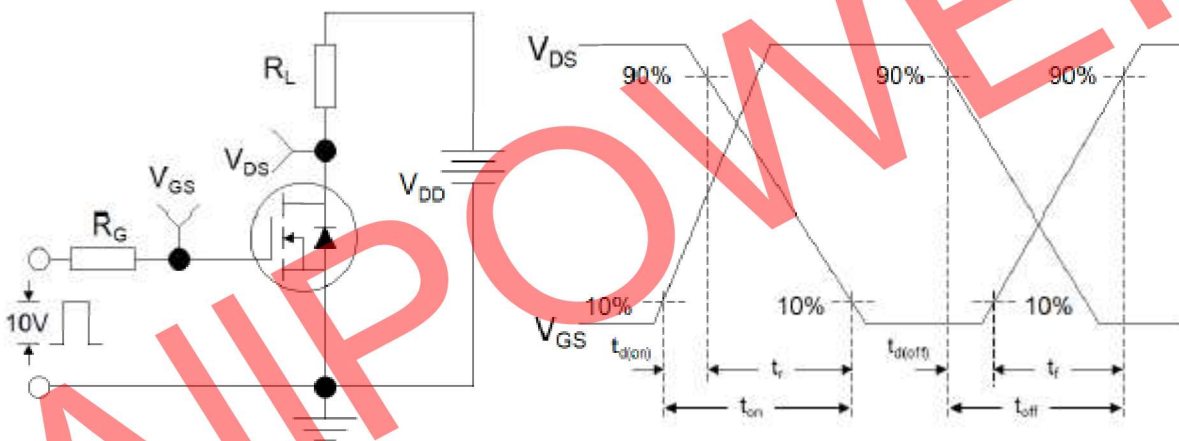

Figure 2: Resistive Switching Test Circuit & Waveforms

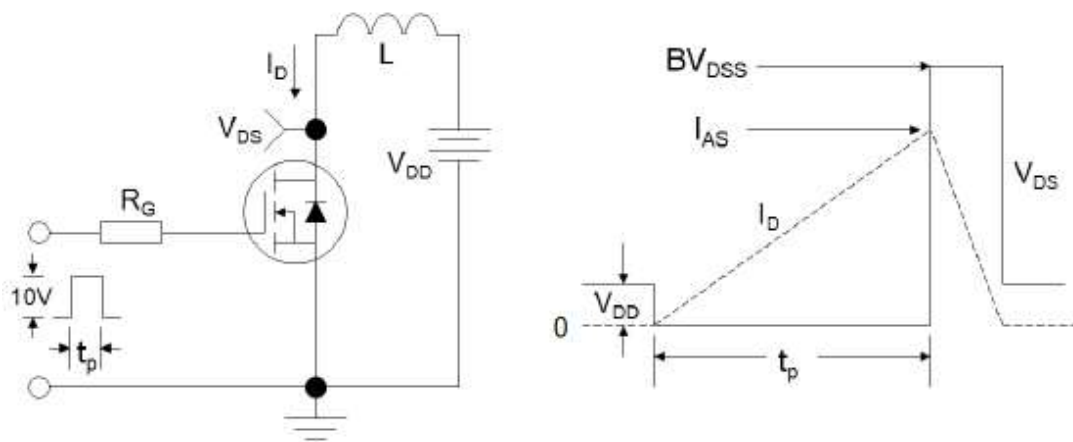
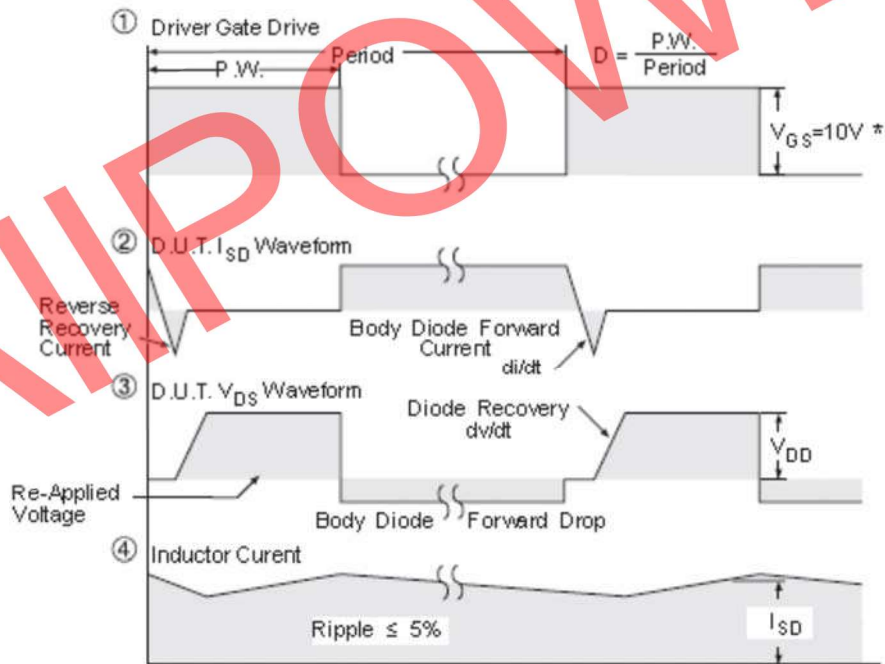
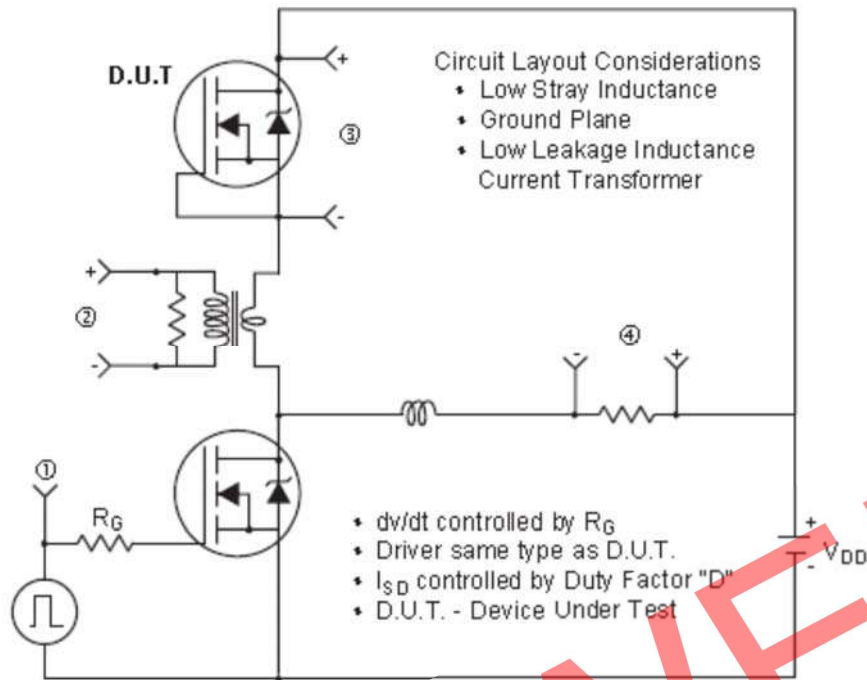

Figure 3:Unclamped Inductive Switching Test Circuit & Waveforms



* $V_{GS} = 5V$ for Logic Level Devices

Figure 4: Peak Diode Recovery dv/dt Test Circuit & Waveforms (For N-channel)

AP30H80K

N-Channel Power MOSFET

Package Mechanical Data

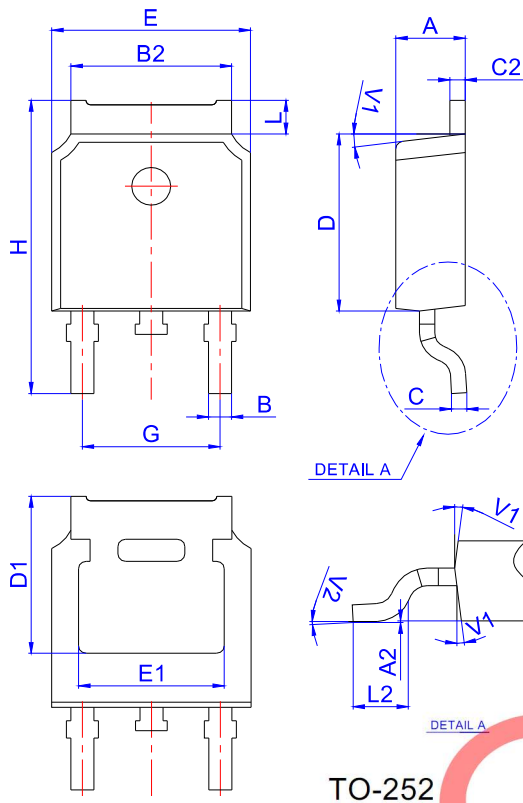

Ref.	Dimensions					
	Millimeters			Inches		
	Min.	Typ.	Max.	Min.	Typ.	Max.
A	2.10		2.50	0.083		0.098
A2	0		0.10	0		0.004
B	0.66		0.86	0.026		0.034
B2	5.18		5.48	0.202		0.216
C	0.40		0.60	0.016		0.024
C2	0.44		0.58	0.017		0.023
D	5.90		6.30	0.232		0.248
D1	5.30REF			0.209REF		
E	6.40		6.80	0.252		0.268
E1	4.63			0.182		
G	4.47		4.67	0.176		0.184
H	9.50		10.70	0.374		0.421
L	1.09		1.21	0.043		0.048
L2	1.35		1.65	0.053		0.065
V1		7°			7°	
V2	0°		6°	0°		6°

Reel Specification-TO-252

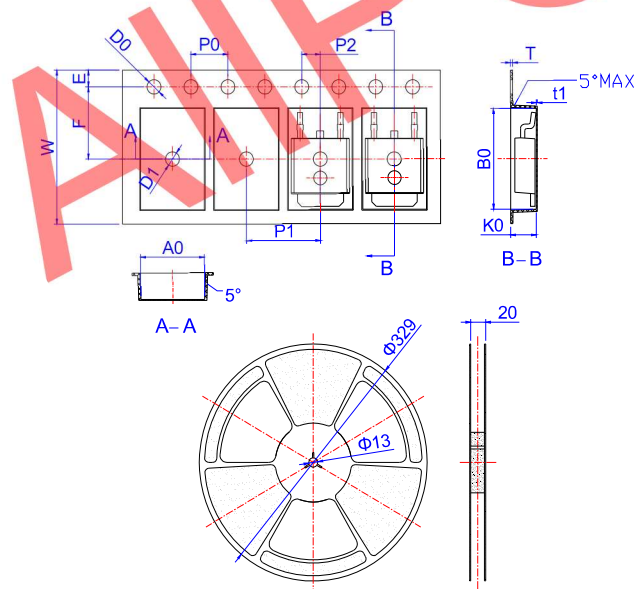

Ref.	Dimensions					
	Millimeters			Inches		
	Min.	Typ.	Max.	Min.	Typ.	Max.
W	15.90	16.00	16.10	0.626	0.630	0.634
E	1.65	1.75	1.85	0.065	0.069	0.073
F	7.40	7.50	7.60	0.291	0.295	0.299
D0	1.40	1.50	1.60	0.055	0.059	0.063
D1	1.40	1.50	1.60	0.055	0.059	0.063
P0	3.90	4.00	4.10	0.154	0.157	0.161
P1	7.90	8.00	8.10	0.311	0.315	0.319
P2	1.90	2.00	2.10	0.075	0.079	0.083
A0	6.85	6.90	7.00	0.270	0.271	0.276
B0	10.45	10.50	10.60	0.411	0.413	0.417
K0	2.68	2.78	2.88	0.105	0.109	0.113
T	0.24		0.27	0.009		0.011
t1	0.10			0.004		
10P0	39.80	40.00	40.20	1.567	1.575	1.583

OUTLINE	REEL (PCS)	PER CARTON (PCS)	TAPE & REEL
TAPING	2,500	25,000	13inch