

SPECIFICATION

规格

Rating:DC 30V 0.5A

额定值: 30V 0.5A

Contact resistance:≤30mΩ

接触电阻: ≤30mΩ

Insulation resistance:≥100mΩ

绝缘电阻: ≥100mΩ

Inertion and extraction force:3~30N

插拔力:3~30N

Life test:5,000 cycles

寿命: 5,000次循环

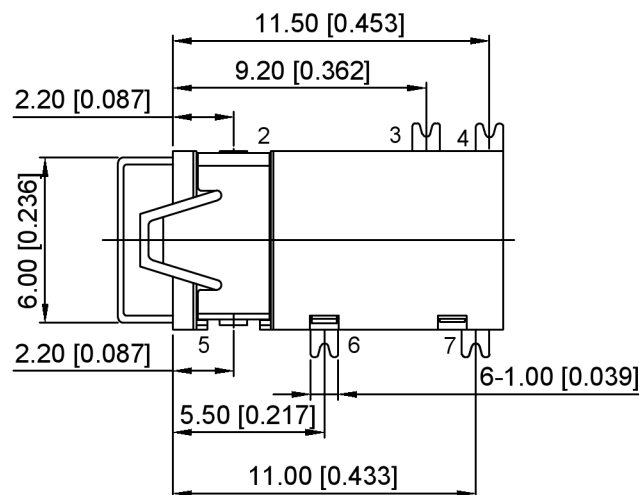
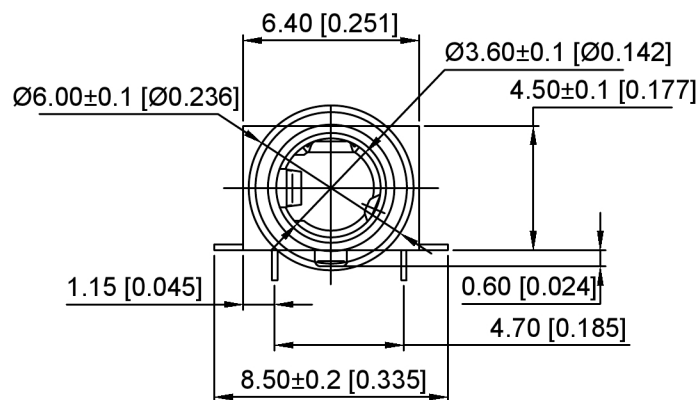

PJ-342CB-TX-SMT

G:Gold plating  
S:Silver plating

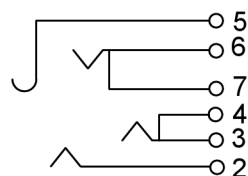
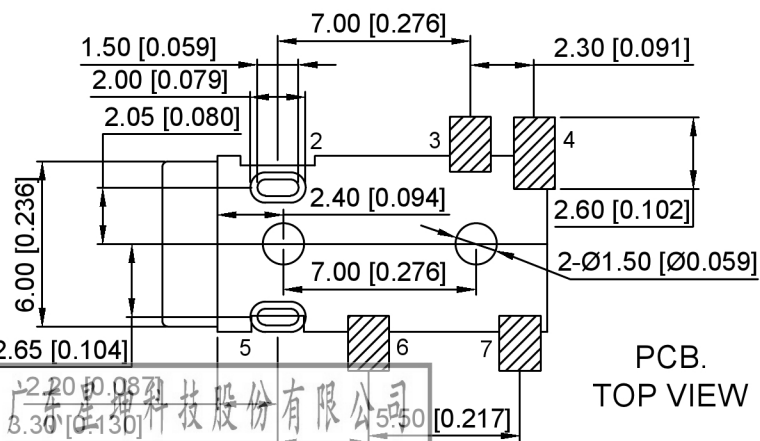

	MATERIAL	PLATING
terminal 2	Phosphor Bronze	Ag
terminal 3	Phosphor Bronze	Ag
terminal 4	Phosphor Bronze	Ag
terminal 5	Phosphor Bronze	Ag
terminal 6	Phosphor Bronze	Ag
terminal 7	Phosphor Bronze	Ag
plastic	High Temp. Thermoplastic	

PCB TOP VIEW

生 效 日期  
文件工程章

REVISIONS	DATE	REVISED	APPROVED	UNSPECIFIED TOLERANCES
				ANGLAR ±5°
				L ≤ 4 ±0.2
				4 < L ≤ 16 ±0.3
				16 < L ≤ 63 ±0.4
				L > 63 ±0.5

DSND		DATE		SCALE: N/A	MODEL TYPE: 3.5 PHONE JACK
DWN		DATE		VIEW:	PART NO.:
CHKD		DATE		UNIT: mm/in	DWG NO.:
APPD		DATE		SIZE: A4	PJ-342CB-TX-SMT

XKB INDUSTRIAL PRECISION CO., LIMITED			WEIGHT	SHEET	REVISION
			1.0g	1/1	A0