

### Features

- Low power consumption
- Low voltage drop
- Low temperature coefficient
- High input voltage (up to 24V)
- High output current : 100mA ( $P_d \leq 250\text{mW}$ )
- Output voltage accuracy: tolerance  $\pm 3\%$
- TO92, SOT89 and SOT23-5 package

### Applications

- Battery-powered equipment
- Communication equipment
- Audio/Video equipment

### General Description

The HT75XX-1 series is a set of three-terminal high current low voltage regulator implemented in CMOS technology. They can deliver 100mA output current and allow an input voltage as high as 24V. They are available with several fixed output voltages ranging from

2.1V to 12.0V. CMOS technology ensures low voltage drop and low quiescent current.

Although designed primarily as fixed voltage regulators, these devices can be used with external components to obtain variable voltages and currents.

### Selection Table

Part No.	Output Voltage	Package	Marking
HT7521-1	2.1V	TO92 SOT89 SOT23-5	75XX-1 (for TO92) 75XX-1 (for SOT89) 5XX1 (for SOT23-5)
HT7523-1	2.3V		
HT7525-1	2.5V		
HT7527-1	2.7V		
HT7530-1	3.0V		
HT7533-1	3.3V		
HT7536-1	3.6V		
HT7540-1	4.0V		
HT7544-1	4.4V		
HT7550-1	5.0V		
HT7560-1	6.0V		
HT7570-1	7.0V		
HT7580-1	8.0V		
HT7590-1	9.0V		
HT75A0-1	10.0V		
HT75C0-1	12.0V		

Note: "XX" stands for output voltages.

For lead free devices, TO92 package will add a "#" mark at the end of the date code, whereas SOT89 & SOT23-5 packages will add a "#" mark at the end of the marking.

### Block Diagram

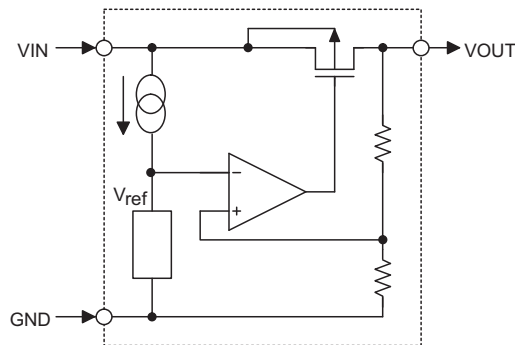

### Pin Assignment

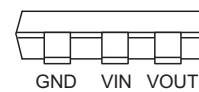
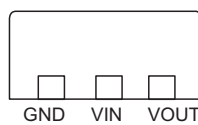
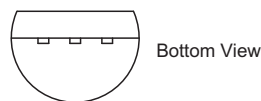
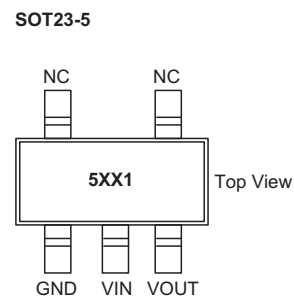
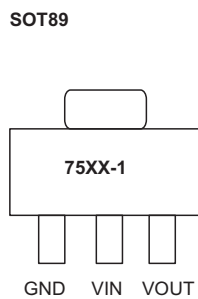
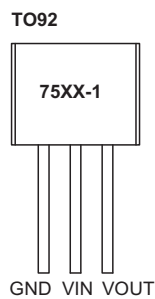

### Absolute Maximum Ratings

Supply Voltage .....	-0.3V to 26V	Storage Temperature .....	-50°C to 125°C
Power Consumption (*1) .....	250mW	Operating Temperature .....	-40°C to 85°C
Power Consumption (*2) .....	150mW		

Note: These are stress ratings only. Stresses exceeding the range specified under "Absolute Maximum Ratings" may cause substantial damage to the device. Functional operation of this device at other conditions beyond those listed in the specification is not implied and prolonged exposure to extreme conditions may affect device reliability.

\*1: applied to SOT89 and TO92

\*2: applied to SOT23-5

### Electrical Characteristics

#### HT7521-1, +2.1V Output Type

Ta=25°C

Symbol	Parameter	Test Conditions		Min.	Typ.	Max.	Unit
		V <sub>IN</sub>	Conditions				
V <sub>OUT</sub>	Output Voltage	4.1V	I <sub>OUT</sub> =10mA	2.037	2.1	2.163	V
I <sub>OUT</sub>	Output Current	4.1V	—	60	100	—	mA
ΔV <sub>OUT</sub>	Load Regulation	4.1V	1mA ≤ I <sub>OUT</sub> ≤ 50mA	—	60	150	mV
V <sub>DIF</sub>	Voltage Drop (Note)	—	I <sub>OUT</sub> =1mA, ΔV <sub>OUT</sub> =2%	—	100	—	mV
I <sub>SS</sub>	Current Consumption	4.1V	No load	—	2.5	5.0	μA
$\frac{\Delta V_{OUT}}{\Delta V_{IN} \times V_{OUT}}$	Line Regulation	—	3.1V ≤ V <sub>IN</sub> ≤ 24V I <sub>OUT</sub> =1mA	—	0.2	—	%/V
V <sub>IN</sub>	Input Voltage	—	—	—	—	24	V
$\frac{\Delta V_{OUT}}{\Delta T_a}$	Temperature Coefficient	4.1V	I <sub>OUT</sub> =10mA 0°C < T <sub>a</sub> < 70°C	—	±0.37	—	mV/°C

Note: Dropout voltage is defined as the input voltage minus the output voltage that produces a 2% change in the output voltage from the value at V<sub>IN</sub> = V<sub>OUT</sub>+2V with a fixed load.

#### HT7523-1, +2.3V Output Type

Ta=25°C

Symbol	Parameter	Test Conditions		Min.	Typ.	Max.	Unit
		V <sub>IN</sub>	Conditions				
V <sub>OUT</sub>	Output Voltage	4.3V	I <sub>OUT</sub> =10mA	2.231	2.3	2.369	V
I <sub>OUT</sub>	Output Current	4.3V	—	60	100	—	mA
ΔV <sub>OUT</sub>	Load Regulation	4.3V	1mA ≤ I <sub>OUT</sub> ≤ 50mA	—	60	150	mV
V <sub>DIF</sub>	Voltage Drop (Note)	—	I <sub>OUT</sub> =1mA, ΔV <sub>OUT</sub> =2%	—	100	—	mV
I <sub>SS</sub>	Current Consumption	4.3V	No load	—	2.5	5.0	μA
$\frac{\Delta V_{OUT}}{\Delta V_{IN} \times V_{OUT}}$	Line Regulation	—	3.3V ≤ V <sub>IN</sub> ≤ 24V I <sub>OUT</sub> =1mA	—	0.2	—	%/V
V <sub>IN</sub>	Input Voltage	—	—	—	—	24	V
$\frac{\Delta V_{OUT}}{\Delta T_a}$	Temperature Coefficient	4.3V	I <sub>OUT</sub> =10mA 0°C < T <sub>a</sub> < 70°C	—	±0.39	—	mV/°C

Note: Dropout voltage is defined as the input voltage minus the output voltage that produces a 2% change in the output voltage from the value at V<sub>IN</sub> = V<sub>OUT</sub>+2V with a fixed load.

**HT7525-1, +2.5V Output Type**

Ta=25°C

Symbol	Parameter	Test Conditions		Min.	Typ.	Max.	Unit
		V <sub>IN</sub>	Conditions				
V <sub>OUT</sub>	Output Voltage	4.5V	I <sub>OUT</sub> =10mA	2.425	2.5	2.575	V
I <sub>OUT</sub>	Output Current	4.5V	—	60	100	—	mA
ΔV <sub>OUT</sub>	Load Regulation	4.5V	1mA ≤ I <sub>OUT</sub> ≤ 50mA	—	60	150	mV
V <sub>DIF</sub>	Voltage Drop (Note)	—	I <sub>OUT</sub> =1mA, ΔV <sub>OUT</sub> =2%	—	100	—	mV
I <sub>SS</sub>	Current Consumption	4.5V	No load	—	2.5	5.0	μA
$\frac{\Delta V_{OUT}}{\Delta V_{IN} \times V_{OUT}}$	Line Regulation	—	3.5V ≤ V <sub>IN</sub> ≤ 24V I <sub>OUT</sub> =1mA	—	0.2	—	%/V
V <sub>IN</sub>	Input Voltage	—	—	—	—	24	V
$\frac{\Delta V_{OUT}}{\Delta T_a}$	Temperature Coefficient	4.5V	I <sub>OUT</sub> =10mA 0°C < Ta < 70°C	—	±0.41	—	mV/°C

Note: Dropout voltage is defined as the input voltage minus the output voltage that produces a 2% change in the output voltage from the value at V<sub>IN</sub> = V<sub>OUT</sub>+2V with a fixed load.

**HT7527-1, +2.7V Output Type**

Ta=25°C

Symbol	Parameter	Test Conditions		Min.	Typ.	Max.	Unit
		V <sub>IN</sub>	Conditions				
V <sub>OUT</sub>	Output Voltage	4.7V	I <sub>OUT</sub> =10mA	2.619	2.7	2.781	V
I <sub>OUT</sub>	Output Current	4.7V	—	60	100	—	mA
ΔV <sub>OUT</sub>	Load Regulation	4.7V	1mA ≤ I <sub>OUT</sub> ≤ 50mA	—	60	150	mV
V <sub>DIF</sub>	Voltage Drop (Note)	—	I <sub>OUT</sub> =1mA, ΔV <sub>OUT</sub> =2%	—	100	—	mV
I <sub>SS</sub>	Current Consumption	4.7V	No load	—	2.5	5.0	μA
$\frac{\Delta V_{OUT}}{\Delta V_{IN} \times V_{OUT}}$	Line Regulation	—	3.7V ≤ V <sub>IN</sub> ≤ 24V I <sub>OUT</sub> =1mA	—	0.2	—	%/V
V <sub>IN</sub>	Input Voltage	—	—	—	—	24	V
$\frac{\Delta V_{OUT}}{\Delta T_a}$	Temperature Coefficient	4.7V	I <sub>OUT</sub> =10mA 0°C < Ta < 70°C	—	±0.43	—	mV/°C

Note: Dropout voltage is defined as the input voltage minus the output voltage that produces a 2% change in the output voltage from the value at V<sub>IN</sub> = V<sub>OUT</sub>+2V with a fixed load.

**HT7530-1, +3.0V Output Type**

Ta=25°C

Symbol	Parameter	Test Conditions		Min.	Typ.	Max.	Unit
		V <sub>IN</sub>	Conditions				
V <sub>OUT</sub>	Output Voltage	5.0V	I <sub>OUT</sub> =10mA	2.91	3.0	3.09	V
I <sub>OUT</sub>	Output Current	5.0V	—	60	100	—	mA
ΔV <sub>OUT</sub>	Load Regulation	5.0V	1mA ≤ I <sub>OUT</sub> ≤ 50mA	—	60	150	mV
V <sub>DIF</sub>	Voltage Drop (Note)	—	I <sub>OUT</sub> =1mA, ΔV <sub>OUT</sub> =2%	—	100	—	mV
I <sub>SS</sub>	Current Consumption	5.0V	No load	—	2.5	5.0	μA
$\frac{\Delta V_{OUT}}{\Delta V_{IN} \times V_{OUT}}$	Line Regulation	—	4.0V ≤ V <sub>IN</sub> ≤ 24V I <sub>OUT</sub> =1mA	—	0.2	—	%/V
V <sub>IN</sub>	Input Voltage	—	—	—	—	24	V
$\frac{\Delta V_{OUT}}{\Delta T_a}$	Temperature Coefficient	5.0V	I <sub>OUT</sub> =10mA 0°C < Ta < 70°C	—	±0.45	—	mV/°C

Note: Dropout voltage is defined as the input voltage minus the output voltage that produces a 2% change in the output voltage from the value at V<sub>IN</sub> = V<sub>OUT</sub>+2V with a fixed load.

**HT7533-1, +3.3V Output Type**

Ta=25°C

Symbol	Parameter	Test Conditions		Min.	Typ.	Max.	Unit
		V <sub>IN</sub>	Conditions				
V <sub>OUT</sub>	Output Voltage	5.5V	I <sub>OUT</sub> =10mA	3.201	3.3	3.399	V
I <sub>OUT</sub>	Output Current	5.5V	—	60	100	—	mA
ΔV <sub>OUT</sub>	Load Regulation	5.5V	1mA ≤ I <sub>OUT</sub> ≤ 50mA	—	60	150	mV
V <sub>DIF</sub>	Voltage Drop (Note)	—	I <sub>OUT</sub> =1mA, ΔV <sub>OUT</sub> =2%	—	100	—	mV
I <sub>SS</sub>	Current Consumption	5.5V	No load	—	2.5	5.0	μA
$\frac{\Delta V_{OUT}}{\Delta V_{IN} \times V_{OUT}}$	Line Regulation	—	4.5V ≤ V <sub>IN</sub> ≤ 24V I <sub>OUT</sub> =1mA	—	0.2	—	%/V
V <sub>IN</sub>	Input Voltage	—	—	—	—	24	V
$\frac{\Delta V_{OUT}}{\Delta T_a}$	Temperature Coefficient	5.5V	I <sub>OUT</sub> =10mA 0°C < Ta < 70°C	—	±0.5	—	mV/°C

Note: Dropout voltage is defined as the input voltage minus the output voltage that produces a 2% change in the output voltage from the value at V<sub>IN</sub> = V<sub>OUT</sub>+2V with a fixed load.

**HT7536-1, +3.6V Output Type**

Ta=25°C

Symbol	Parameter	Test Conditions		Min.	Typ.	Max.	Unit
		V <sub>IN</sub>	Conditions				
V <sub>OUT</sub>	Output Voltage	5.6V	I <sub>OUT</sub> =10mA	3.492	3.6	3.708	V
I <sub>OUT</sub>	Output Current	5.6V	—	60	100	—	mA
ΔV <sub>OUT</sub>	Load Regulation	5.6V	1mA≤I <sub>OUT</sub> ≤50mA	—	60	150	mV
V <sub>DIF</sub>	Voltage Drop (Note)	—	I <sub>OUT</sub> =1mA, ΔV <sub>OUT</sub> =2%	—	100	—	mV
I <sub>SS</sub>	Current Consumption	5.6V	No load	—	2.5	5.0	μA
$\frac{\Delta V_{OUT}}{\Delta V_{IN} \times V_{OUT}}$	Line Regulation	—	4.6V≤V <sub>IN</sub> ≤24V I <sub>OUT</sub> =1mA	—	0.2	—	%/V
V <sub>IN</sub>	Input Voltage	—	—	—	—	24	V
$\frac{\Delta V_{OUT}}{\Delta T_a}$	Temperature Coefficient	5.6V	I <sub>OUT</sub> =10mA 0°C<Ta<70°C	—	±0.6	—	mV/°C

Note: Dropout voltage is defined as the input voltage minus the output voltage that produces a 2% change in the output voltage from the value at V<sub>IN</sub> = V<sub>OUT</sub>+2V with a fixed load.

**HT7540-1, +4.0V Output Type**

Ta=25°C

Symbol	Parameter	Test Conditions		Min.	Typ.	Max.	Unit
		V <sub>IN</sub>	Conditions				
V <sub>OUT</sub>	Output Voltage	6.0V	I <sub>OUT</sub> =10mA	3.88	4.0	4.12	V
I <sub>OUT</sub>	Output Current	6.0V	—	60	100	—	mA
ΔV <sub>OUT</sub>	Load Regulation	6.0V	1mA≤I <sub>OUT</sub> ≤50mA	—	60	150	mV
V <sub>DIF</sub>	Voltage Drop (Note)	—	I <sub>OUT</sub> =1mA, ΔV <sub>OUT</sub> =2%	—	100	—	mV
I <sub>SS</sub>	Current Consumption	6.0V	No load	—	2.5	5.0	μA
$\frac{\Delta V_{OUT}}{\Delta V_{IN} \times V_{OUT}}$	Line Regulation	—	5.0V≤V <sub>IN</sub> ≤24V I <sub>OUT</sub> =1mA	—	0.2	—	%/V
V <sub>IN</sub>	Input Voltage	—	—	—	—	24	V
$\frac{\Delta V_{OUT}}{\Delta T_a}$	Temperature Coefficient	6.0V	I <sub>OUT</sub> =10mA 0°C<Ta<70°C	—	±0.7	—	mV/°C

Note: Dropout voltage is defined as the input voltage minus the output voltage that produces a 2% change in the output voltage from the value at V<sub>IN</sub> = V<sub>OUT</sub>+2V with a fixed load.

**HT7544-1, +4.4V Output Type**

Ta=25°C

Symbol	Parameter	Test Conditions		Min.	Typ.	Max.	Unit
		V <sub>IN</sub>	Conditions				
V <sub>OUT</sub>	Output Voltage	6.4V	I <sub>OUT</sub> =10mA	4.268	4.4	4.532	V
I <sub>OUT</sub>	Output Current	6.4V	—	60	100	—	mA
ΔV <sub>OUT</sub>	Load Regulation	6.4V	1mA ≤ I <sub>OUT</sub> ≤ 50mA	—	60	150	mV
V <sub>DIF</sub>	Voltage Drop (Note)	—	I <sub>OUT</sub> =1mA, ΔV <sub>OUT</sub> =2%	—	100	—	mV
I <sub>SS</sub>	Current Consumption	6.4V	No load	—	2.5	5.0	μA
$\frac{\Delta V_{OUT}}{\Delta V_{IN} \times V_{OUT}}$	Line Regulation	—	5.4V ≤ V <sub>IN</sub> ≤ 24V I <sub>OUT</sub> =1mA	—	0.2	—	%/V
V <sub>IN</sub>	Input Voltage	—	—	—	—	24	V
$\frac{\Delta V_{OUT}}{\Delta T_a}$	Temperature Coefficient	6.4V	I <sub>OUT</sub> =10mA 0°C < Ta < 70°C	—	±0.7	—	mV/°C

Note: Dropout voltage is defined as the input voltage minus the output voltage that produces a 2% change in the output voltage from the value at V<sub>IN</sub> = V<sub>OUT</sub>+2V with a fixed load.

**HT7550-1, +5.0V Output Type**

Ta=25°C

Symbol	Parameter	Test Conditions		Min.	Typ.	Max.	Unit
		V <sub>IN</sub>	Conditions				
V <sub>OUT</sub>	Output Voltage	7.0V	I <sub>OUT</sub> =10mA	4.85	5.0	5.15	V
I <sub>OUT</sub>	Output Current	7.0V	—	100	150	—	mA
ΔV <sub>OUT</sub>	Load Regulation	7.0V	1mA ≤ I <sub>OUT</sub> ≤ 70mA	—	60	150	mV
V <sub>DIF</sub>	Voltage Drop (Note)	—	I <sub>OUT</sub> =1mA, ΔV <sub>OUT</sub> =2%	—	100	—	mV
I <sub>SS</sub>	Current Consumption	7.0V	No load	—	2.5	5.0	μA
$\frac{\Delta V_{OUT}}{\Delta V_{IN} \times V_{OUT}}$	Line Regulation	—	6.0V ≤ V <sub>IN</sub> ≤ 24V I <sub>OUT</sub> =1mA	—	0.2	—	%/V
V <sub>IN</sub>	Input Voltage	—	—	—	—	24	V
$\frac{\Delta V_{OUT}}{\Delta T_a}$	Temperature Coefficient	7.0V	I <sub>OUT</sub> =10mA 0°C < Ta < 70°C	—	±0.75	—	mV/°C

Note: Dropout voltage is defined as the input voltage minus the output voltage that produces a 2% change in the output voltage from the value at V<sub>IN</sub> = V<sub>OUT</sub>+2V with a fixed load.

### HT7560-1, +6.0V Output Type

Ta=25°C

Symbol	Parameter	Test Conditions		Min.	Typ.	Max.	Unit
		V <sub>IN</sub>	Conditions				
V <sub>OUT</sub>	Output Voltage	8.0V	I <sub>OUT</sub> =10mA	5.82	6.0	6.18	V
I <sub>OUT</sub>	Output Current	8.0V	—	150	—	—	mA
ΔV <sub>OUT</sub>	Load Regulation	8.0V	1mA ≤ I <sub>OUT</sub> ≤ 70mA	—	60	150	mV
V <sub>DIF</sub>	Voltage Drop (Note)	—	I <sub>OUT</sub> =1mA, ΔV <sub>OUT</sub> =2%	—	100	—	mV
I <sub>SS</sub>	Current Consumption	8.0V	No load	—	2.5	5.0	μA
$\frac{\Delta V_{OUT}}{\Delta V_{IN} \times V_{OUT}}$	Line Regulation	—	7.0V ≤ V <sub>IN</sub> ≤ 24V I <sub>OUT</sub> =1mA	—	0.2	—	%/V
V <sub>IN</sub>	Input Voltage	—	—	—	—	24	V
$\frac{\Delta V_{OUT}}{\Delta T_a}$	Temperature Coefficient	8.0V	I <sub>OUT</sub> =10mA 0°C < Ta < 70°C	—	±0.85	—	mV/°C

Note: Dropout voltage is defined as the input voltage minus the output voltage that produces a 2% change in the output voltage from the value at V<sub>IN</sub> = V<sub>OUT</sub>+2V with a fixed load.

### HT7570-1, +7.0V Output Type

Ta=25°C

Symbol	Parameter	Test Conditions		Min.	Typ.	Max.	Unit
		V <sub>IN</sub>	Conditions				
V <sub>OUT</sub>	Output Voltage	9.0V	I <sub>OUT</sub> =10mA	6.79	7.0	7.21	V
I <sub>OUT</sub>	Output Current	9.0V	—	150	—	—	mA
ΔV <sub>OUT</sub>	Load Regulation	9.0V	1mA ≤ I <sub>OUT</sub> ≤ 70mA	—	60	150	mV
V <sub>DIF</sub>	Voltage Drop (Note)	—	I <sub>OUT</sub> =1mA, ΔV <sub>OUT</sub> =2%	—	100	—	mV
I <sub>SS</sub>	Current Consumption	9.0V	No load	—	2.5	5.0	μA
$\frac{\Delta V_{OUT}}{\Delta V_{IN} \times V_{OUT}}$	Line Regulation	—	8.0V ≤ V <sub>IN</sub> ≤ 24V =1mA	—	0.2	—	%/V
V <sub>IN</sub>	Input Voltage	—	—	—	—	24	V
$\frac{\Delta V_{OUT}}{\Delta T_a}$	Temperature Coefficient	9.0V	I <sub>OUT</sub> =10mA 0°C < Ta < 70°C	—	±0.95	—	mV/°C

Note: Dropout voltage is defined as the input voltage minus the output voltage that produces a 2% change in the output voltage from the value at V<sub>IN</sub> = V<sub>OUT</sub>+2V with a fixed load.



### HT7580-1, +8.0V Output Type

Ta=25°C

Symbol	Parameter	Test Conditions		Min.	Typ.	Max.	Unit
		V <sub>IN</sub>	Conditions				
V <sub>OUT</sub>	Output Voltage	10V	I <sub>OUT</sub> =10mA	7.76	8.0	8.24	V
I <sub>OUT</sub>	Output Current	10V	—	150	—	—	mA
ΔV <sub>OUT</sub>	Load Regulation	10V	1mA ≤ I <sub>OUT</sub> ≤ 70mA	—	60	150	mV
V <sub>DIF</sub>	Voltage Drop (Note)	—	I <sub>OUT</sub> =1mA, ΔV <sub>OUT</sub> =2%	—	100	—	mV
I <sub>SS</sub>	Current Consumption	10V	No load	—	2.5	5.0	μA
$\frac{\Delta V_{OUT}}{\Delta V_{IN} \times V_{OUT}}$	Line Regulation	—	9.0V ≤ V <sub>IN</sub> ≤ 24V I <sub>OUT</sub> =1mA	—	0.2	—	%/V
V <sub>IN</sub>	Input Voltage	—	—	—	—	24	V
$\frac{\Delta V_{OUT}}{\Delta T_a}$	Temperature Coefficient	10V	I <sub>OUT</sub> =10mA 0°C < Ta < 70°C	—	±1.10	—	mV/°C

Note: Dropout voltage is defined as the input voltage minus the output voltage that produces a 2% change in the output voltage from the value at V<sub>IN</sub> = V<sub>OUT</sub>+2V with a fixed load.

### HT7590-1, +9.0V Output Type

Ta=25°C

Symbol	Parameter	Test Conditions		Min.	Typ.	Max.	Unit
		V <sub>IN</sub>	Conditions				
V <sub>OUT</sub>	Output Voltage	11V	I <sub>OUT</sub> =10mA	8.73	9.0	9.27	V
I <sub>OUT</sub>	Output Current	11V	—	150	—	—	mA
ΔV <sub>OUT</sub>	Load Regulation	11V	1mA ≤ I <sub>OUT</sub> ≤ 70mA	—	60	150	mV
V <sub>DIF</sub>	Voltage Drop (Note)	—	I <sub>OUT</sub> =1mA, ΔV <sub>OUT</sub> =2%	—	100	—	mV
I <sub>SS</sub>	Current Consumption	11V	No load	—	2.5	5.0	μA
$\frac{\Delta V_{OUT}}{\Delta V_{IN} \times V_{OUT}}$	Line Regulation	—	10V ≤ V <sub>IN</sub> ≤ 24V I <sub>OUT</sub> =1mA	—	0.2	—	%/V
V <sub>IN</sub>	Input Voltage	—	—	—	—	24	V
$\frac{\Delta V_{OUT}}{\Delta T_a}$	Temperature Coefficient	11V	I <sub>OUT</sub> =10mA 0°C < Ta < 70°C	—	±1.15	—	mV/°C

Note: Dropout voltage is defined as the input voltage minus the output voltage that produces a 2% change in the output voltage from the value at V<sub>IN</sub> = V<sub>OUT</sub>+2V with a fixed load.

### HT75A0-1, +10.0V Output Type

Ta=25°C

Symbol	Parameter	Test Conditions		Min.	Typ.	Max.	Unit
		V <sub>IN</sub>	Conditions				
V <sub>OUT</sub>	Output Voltage	12V	I <sub>OUT</sub> =10mA	9.7	10.0	10.3	V
I <sub>OUT</sub>	Output Current	12V	—	150	—	—	mA
ΔV <sub>OUT</sub>	Load Regulation	12V	1mA ≤ I <sub>OUT</sub> ≤ 70mA	—	60	150	mV
V <sub>DIF</sub>	Voltage Drop (Note)	—	I <sub>OUT</sub> =1mA, ΔV <sub>OUT</sub> =2%	—	100	—	mV
I <sub>SS</sub>	Current Consumption	12V	No load	—	2.5	5.0	μA
$\frac{\Delta V_{OUT}}{\Delta V_{IN} \times V_{OUT}}$	Line Regulation	—	11V ≤ V <sub>IN</sub> ≤ 24V I <sub>OUT</sub> =1mA	—	0.2	—	%/V
V <sub>IN</sub>	Input Voltage	—	—	—	—	24	V
$\frac{\Delta V_{OUT}}{\Delta T_a}$	Temperature Coefficient	12V	I <sub>OUT</sub> =10mA 0°C < T <sub>a</sub> < 70°C	—	±1.25	—	mV/°C

Note: Dropout voltage is defined as the input voltage minus the output voltage that produces a 2% change in the output voltage from the value at V<sub>IN</sub> = V<sub>OUT</sub>+2V with a fixed load.

### HT75C0-1, +12.0V Output Type

Ta=25°C

Symbol	Parameter	Test Conditions		Min.	Typ.	Max.	Unit
		V <sub>IN</sub>	Conditions				
V <sub>OUT</sub>	Output Voltage	14V	I <sub>OUT</sub> =10mA	11.64	12.0	12.36	V
I <sub>OUT</sub>	Output Current	14V	—	150	—	—	mA
ΔV <sub>OUT</sub>	Load Regulation	14V	1mA ≤ I <sub>OUT</sub> ≤ 70mA	—	60	150	mV
V <sub>DIF</sub>	Voltage Drop (Note)	—	I <sub>OUT</sub> =1mA, ΔV <sub>OUT</sub> =2%	—	100	—	mV
I <sub>SS</sub>	Current Consumption	14V	No load	—	2.5	5.0	μA
$\frac{\Delta V_{OUT}}{\Delta V_{IN} \times V_{OUT}}$	Line Regulation	—	13V ≤ V <sub>IN</sub> ≤ 24V I <sub>OUT</sub> =1mA	—	0.2	—	%/V
V <sub>IN</sub>	Input Voltage	—	—	—	—	24	V
$\frac{\Delta V_{OUT}}{\Delta T_a}$	Temperature Coefficient	14V	I <sub>OUT</sub> =10mA 0°C < T <sub>a</sub> < 70°C	—	±1.45	—	mV/°C

Note: Dropout voltage is defined as the input voltage minus the output voltage that produces a 2% change in the output voltage from the value at V<sub>IN</sub> = V<sub>OUT</sub>+2V with a fixed load.

## Application Circuits

### Basic Circuit

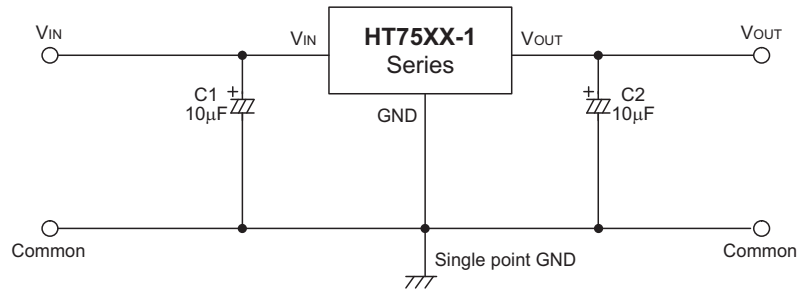

### High Output Current Positive Voltage Regulator

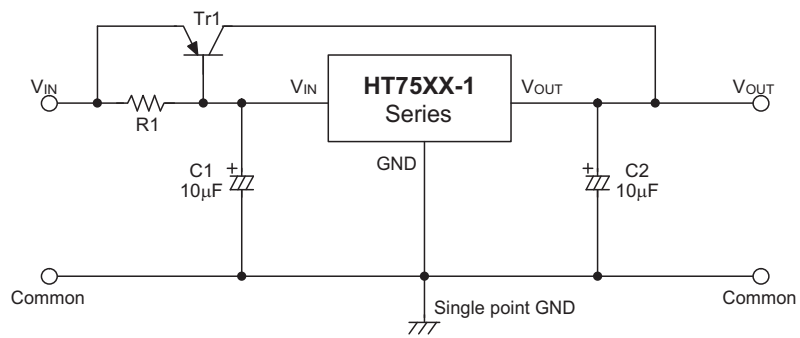

### Short-Circuit Protection for Tr1

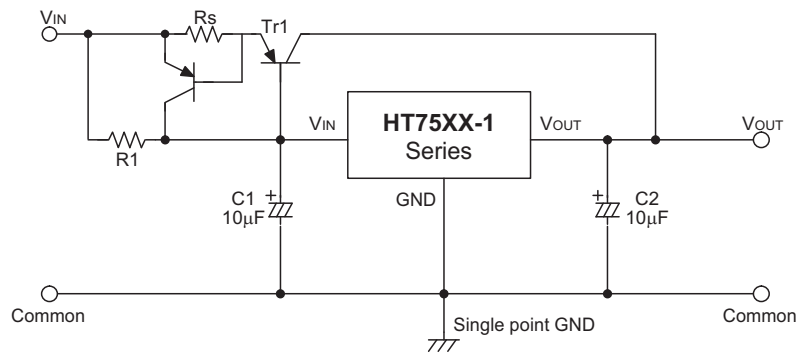

### Circuit for Increasing Output Voltage

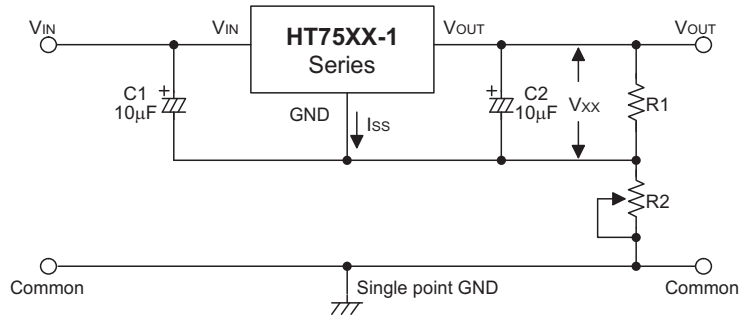

$$V_{OUT} = V_{xx} \left( 1 + \frac{R2}{R1} \right) + I_{ss} R2$$

### Circuit for Increasing Output Voltage

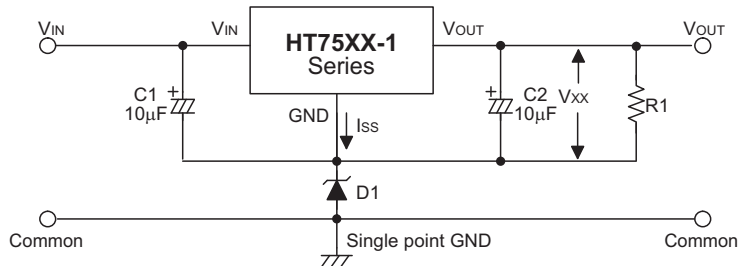

$$V_{OUT} = V_{xx} + V_{D1}$$

### Constant Current Regulator

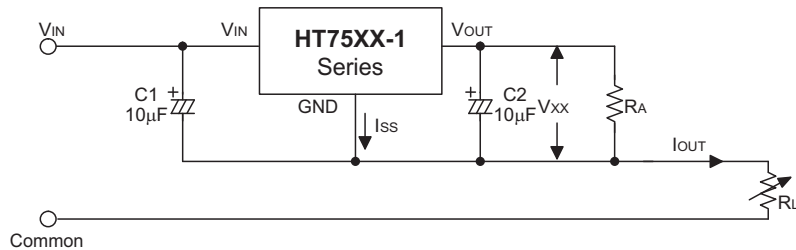

$$I_{OUT} = \frac{V_{xx}}{R_A} + I_{ss}$$

### Dual Supply

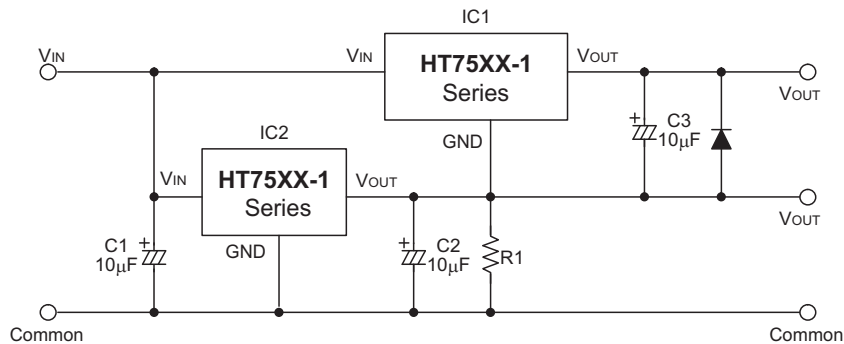

## Package Information

### 3-pin TO92 Outline Dimensions

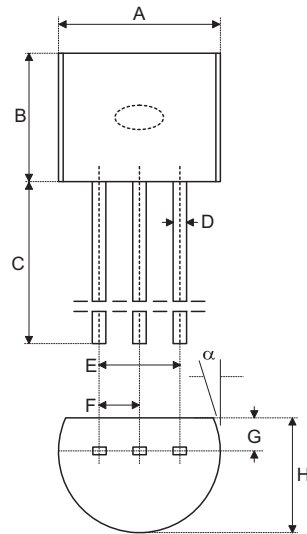

Symbol	Dimensions in inch		
	Min.	Nom.	Max.
A	0.170	—	0.200
B	0.170	—	0.200
C	0.500	—	—
D	0.011	—	0.020
E	0.090	—	0.110
F	0.045	—	0.055
G	0.045	—	0.065
H	0.130	—	0.160
α	0°	—	10°

Symbol	Dimensions in mm		
	Min.	Nom.	Max.
A	4.32	—	5.08
B	4.32	—	5.08
C	12.70	—	—
D	0.28	—	0.51
E	2.29	—	2.79
F	1.14	—	1.40
G	1.14	—	1.65
H	3.30	—	4.06
α	0°	—	10°

### 3-pin SOT89 Outline Dimensions

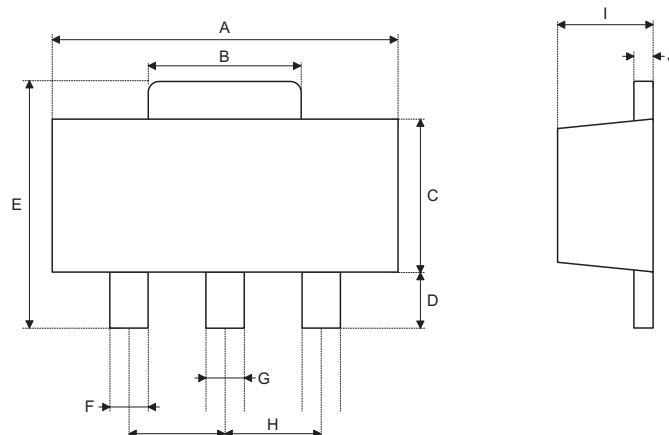

Symbol	Dimensions in inch		
	Min.	Nom.	Max.
A	0.173	—	0.181
B	0.059	—	0.072
C	0.090	—	0.102
D	0.035	—	0.047
E	0.155	—	0.167
F	0.014	—	0.019
G	0.017	—	0.022
H	—	0.059	—
I	55	—	63
J	14	—	17

Symbol	Dimensions in mm		
	Min.	Nom.	Max.
A	4.39	—	4.60
B	1.50	—	1.83
C	2.29	—	2.59
D	0.89	—	1.19
E	3.94	—	4.24
F	0.36	—	0.48
G	0.43	—	0.56
H	—	1.50	—
I	1.40	—	1.60
J	0.36	—	0.43

## 5-pin SOT23-5 Outline Dimensions

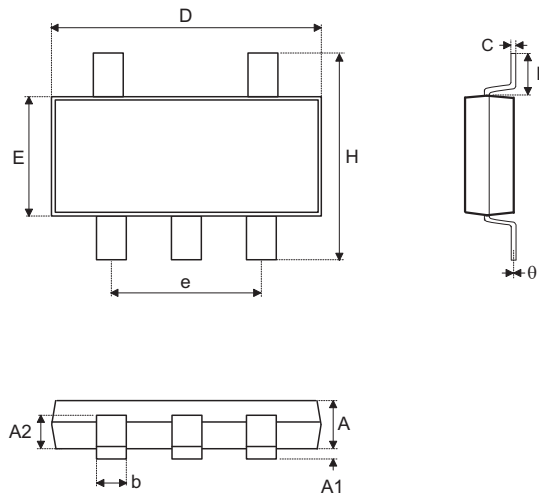

Symbol	Dimensions in inch		
	Min.	Nom.	Max.
A	0.039	—	0.051
A1	—	—	0.004
A2	0.028	—	0.035
b	0.014	—	0.020
C	0.004	—	0.010
D	0.106	—	0.122
E	0.055	—	0.071
e	—	0.075	—
H	0.102	—	0.118
L	0.015	—	—
$\theta$	0°	—	9°

Symbol	Dimensions in mm		
	Min.	Nom.	Max.
A	1.00	—	1.30
A1	—	—	0.10
A2	0.70	—	0.90
b	0.35	—	0.50
C	0.10	—	0.25
D	2.70	—	3.10
E	1.40	—	1.80
e	—	1.90	—
H	2.60	—	3.0
L	0.37	—	—
$\theta$	0°	—	9°

## Product Tape and Reel Specifications

TO92 Reel Dimensions (Unit: mm)

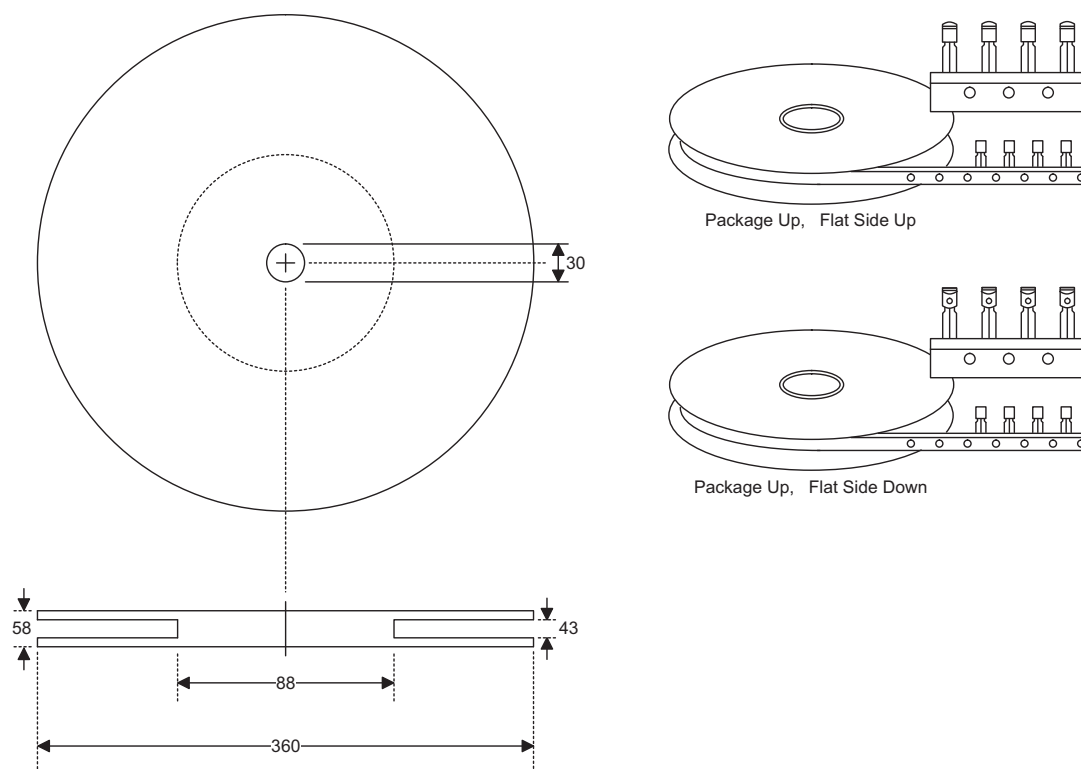



## Reel Dimensions

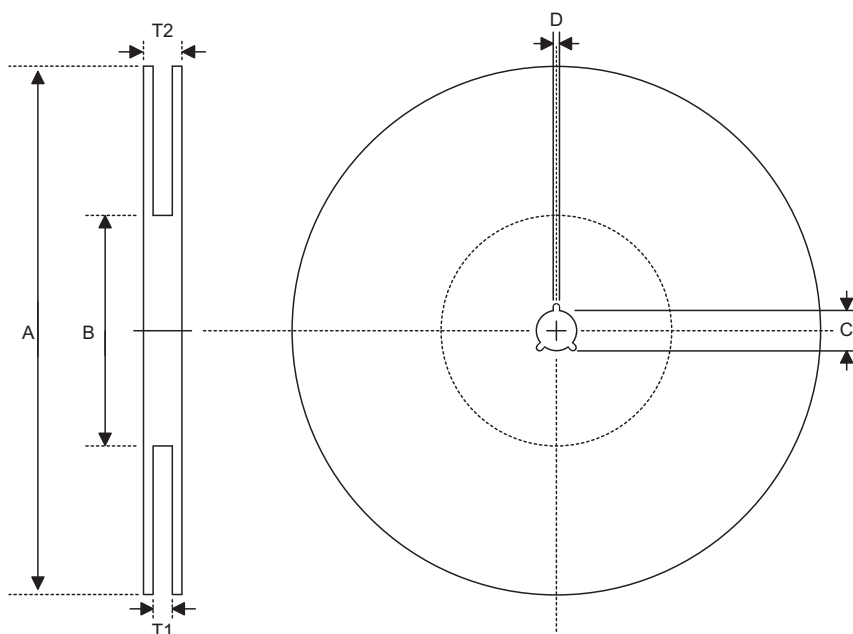

### SOT89

Symbol	Description	Dimensions in mm
A	Reel Outer Diameter	180.0±1.0
B	Reel Inner Diameter	62.0±1.5
C	Spindle Hole Diameter	12.75 <sup>+0.15/-0.00</sup>
D	Key Slit Width	1.90±0.15
T1	Space Between Flange	12.4 <sup>+0.2/-0.0</sup>
T2	Reel Thickness	17.0 <sup>+0.0/-0.4</sup>

### SOT23-5

Symbol	Description	Dimensions in mm
A	Reel Outer Diameter	178.0±1.0
B	Reel Inner Diameter	62.0±1.0
C	Spindle Hole Diameter	13.0±0.2
D	Key Slit Width	2.50±0.25
T1	Space Between Flange	8.4 <sup>+1.5/-0.0</sup>
T2	Reel Thickness	11.4 <sup>+1.5/-0.0</sup>

### Carrier Tape Dimensions

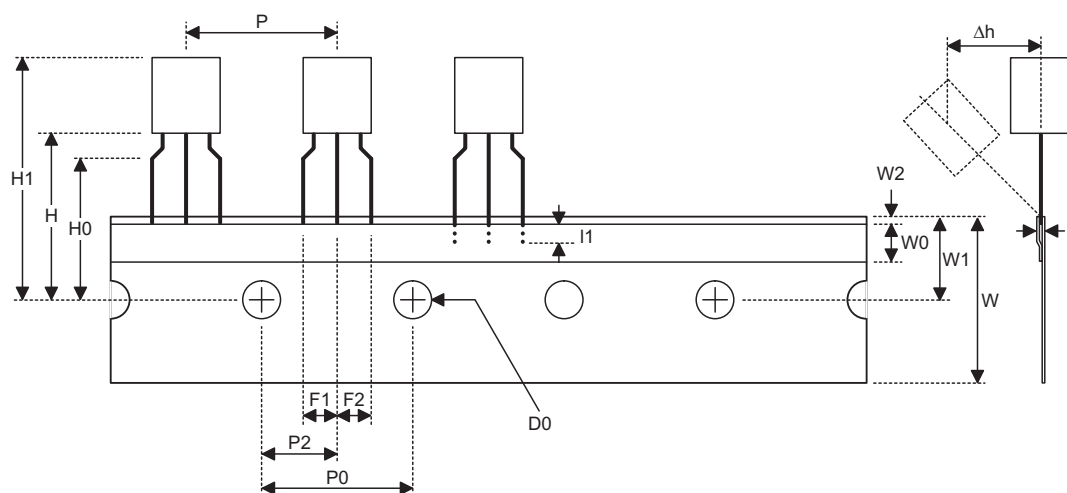

### TO92

Symbol	Description	Dimensions in mm
I1	Taped Lead Length	(2.5)
P	Component Pitch	12.7±1.0
P <sub>0</sub>	Perforation Pitch	12.7±0.3
P <sub>2</sub>	Component to Perforation (Length Direction)	6.35±0.40
F <sub>1</sub>	Lead Spread	2.5 <sup>+0.4/-0.1</sup>
F <sub>2</sub>	Lead Spread	2.5 <sup>+0.4/-0.1</sup>
Δh	Component Alignment	0.0±0.1
W	Carrier Tape Width	18.0 <sup>+1.0/-0.5</sup>
W <sub>0</sub>	Hold-down Tape Width	6.0±0.5
W <sub>1</sub>	Perforation Position	9.0±0.5
W <sub>2</sub>	Hold-down Tape Position	(0.5)
H <sub>0</sub>	Lead Clinch Height	16.0±0.5
H <sub>1</sub>	Component Height	Less than 24.7
D <sub>0</sub>	Perforation Diameter	4.0±0.2
t	Taped Lead Thickness	0.7±0.2
H	Component Base Height	19.0±0.5

Note: Thickness less than 0.38±0.05mm~0.5mm  
 P<sub>0</sub> Accumulated pitch tolerance: ±1mm/20pitches.  
 ( ) Bracketed figures are for consultation only

### Carrier Tape Dimensions

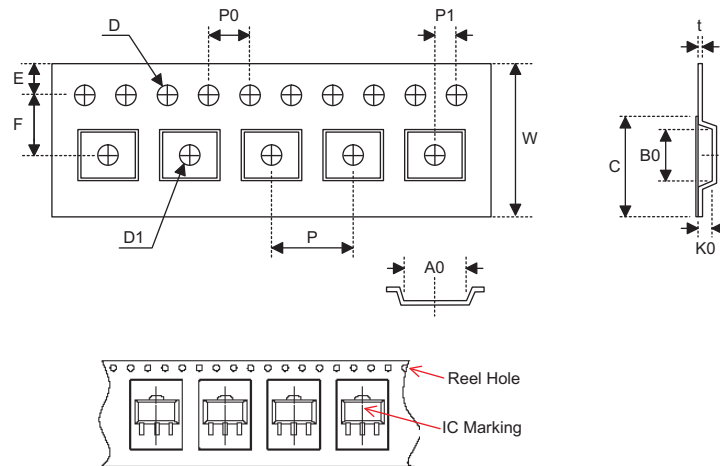

#### SOT89

Symbol	Description	Dimensions in mm
W	Carrier Tape Width	12.0 <sup>+0.3/-0.1</sup>
P	Cavity Pitch	8.0±0.1
E	Perforation Position	1.75±0.10
F	Cavity to Perforation (Width Direction)	5.50±0.05
D	Perforation Diameter	1.5 <sup>+0.1/-0.0</sup>
D1	Cavity Hole Diameter	1.5 <sup>+0.1/-0.0</sup>
P0	Perforation Pitch	4.0±0.1
P1	Cavity to Perforation (Length Direction)	2.0±0.1
A0	Cavity Length	4.8±0.1
B0	Cavity Width	4.5±0.1
K0	Cavity Depth	1.8±0.1
t	Carrier Tape Thickness	0.300±0.013
C	Cover Tape Width	9.3±0.1

#### SOT23-5

Symbol	Description	Dimensions in mm
W	Carrier Tape Width	8.0±0.3
P	Cavity Pitch	4.0±0.1
E	Perforation Position	1.75±0.10
F	Cavity to Perforation (Width Direction)	3.50±0.05
D	Perforation Diameter	1.5 <sup>+0.1/-0.0</sup>
D1	Cavity Hole Diameter	1.5 <sup>+0.1/-0.0</sup>
P0	Perforation Pitch	4.0±0.1
P1	Cavity to Perforation (Length Direction)	2.00±0.05
A0	Cavity Length	3.15±0.10
B0	Cavity Width	3.2±0.1
K0	Cavity Depth	1.4±0.1
t	Carrier Tape Thickness	0.20±0.03
C	Cover Tape Width	5.3±0.1

<http://www.tschip.cn>

The final right of interpretation belongs to Shenzhen Tongsheng Electronics Co., Ltd