

PART No.	Pos	A	B	C	D	E	F
20709-010E-##-□	10	1.40	3.92	3.75	2.70	4.10	-
20709-014E-##-□	14	2.10	4.62	4.45	3.40	4.80	-
20709-018E-##-□	18	2.80	5.32	5.15	4.10	5.50	-
20709-020E-##-□	20	3.15	5.67	5.50	4.45	5.85	-
20709-024E-##-□	24	3.85	6.37	6.20	5.15	6.55	-
20709-030E-##-□	30	4.90	7.42	7.25	6.20	7.60	-
20709-034E-##-□	34	5.60	8.12	7.95	6.90	8.30	-
20709-040E-##-□	40	6.65	9.17	9.00	7.95	9.35	-
20709-050E-##-□	50	8.40	10.92	10.75	9.70	11.10	-
20709-060E-##-□	60	10.15	12.67	12.50	11.45	12.85	2.10

PART No.	CONDUCTIVITY TYPE (##)	QTY. IN REEL (□)	APPLICABLE POSITION NUMBER (**)													
20709-0**E-##-□																
20709-0**E	NORMAL(NONE)	20,000(NONE)	-	-	-	-	-	-	-	-	-	34	40	50	-	
20709-0**E-00-M	NORMAL(00)	5,000(M)	-	-	-	-	-	-	-	-	-	34	40	50	-	
20709-0**E-01	HIGH(01)	20,000(NONE)	10	14	18	20	24	30	34	40	50	60	-	-	-	
20709-0**E-01-M	HIGH(01)	5,000(M)	10	14	18	20	24	30	34	40	50	60	-	-	-	

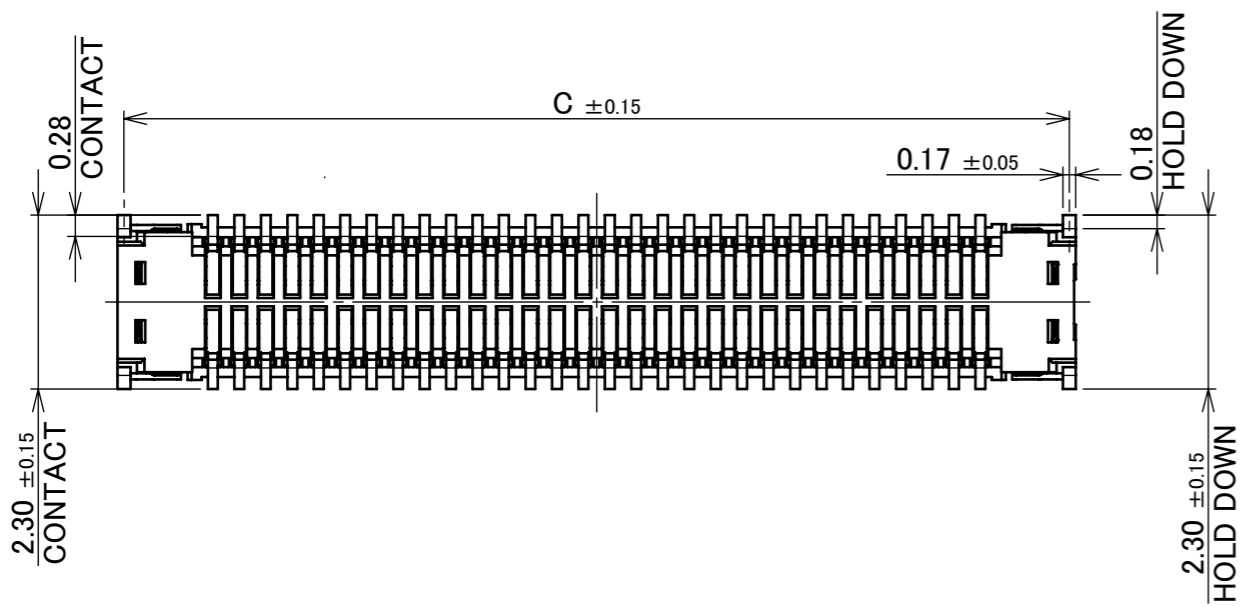
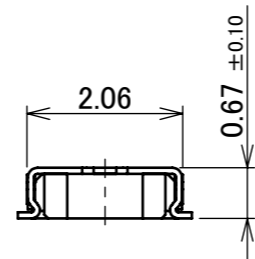
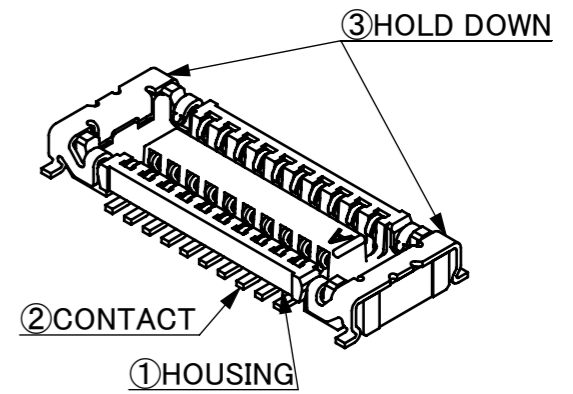
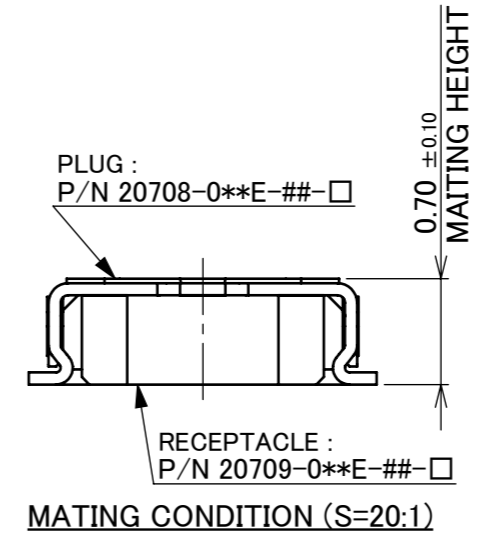
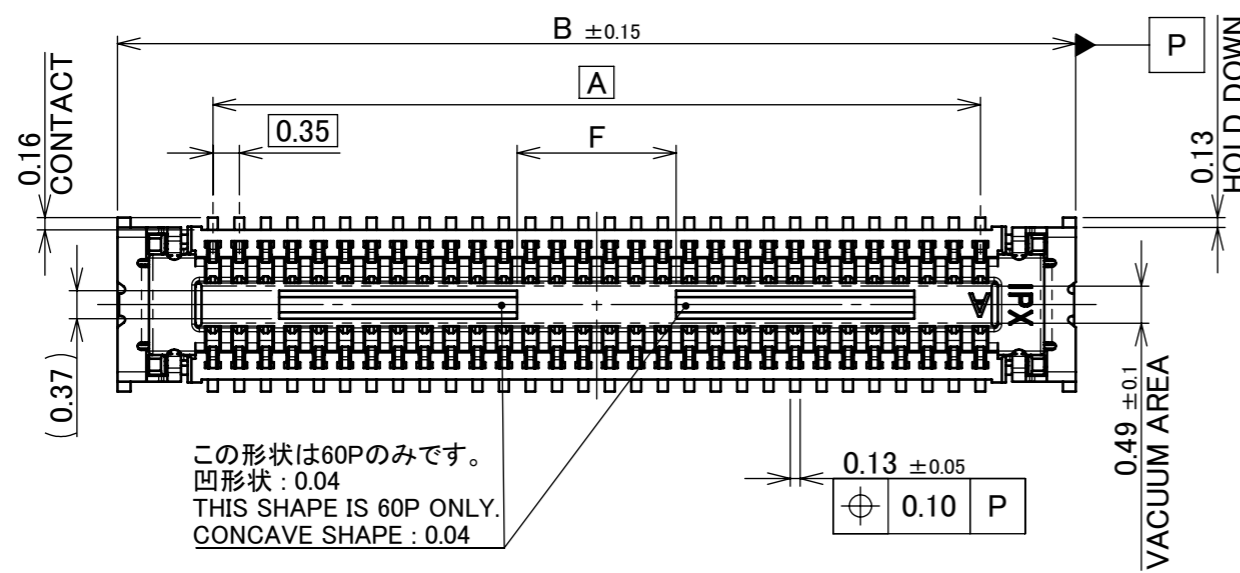

NO.	DISCRIPTION	MATERIAL	FINISH , REMARKS
3	HOLD DOWN	CORSON ALLOY	ALL OVER Ni 1.27 μm MIN. CONTACT PART Au 0.1 μm MIN./ SOLDERING PART Au 0.01 μm MIN.
2	CONTACT	PHOSPHOR BRONZE P/N : 20709-0**E CORSON ALLOY P/N : 20709-0**E-00-M	ALL OVER Ni 1.27 μm MIN. CONTACT PART Au 0.1 μm MIN./ SOLDERING PART Au 0.01 μm MIN.
1	HOUSING	LCP	UL94V-0, BEIGE

REV.	ECN	BY	DATE	APP.	APP.	CHK.	DATE	APP.	PROJECTION	SERIES No.	TITLE	SCALE	SHEET	REV.
14	Z220204	K.W	2022/02/28	Y.H	ANGLE	±2°	6 OVER 30 MAX.	±0.3	PROJECTION	R2	NOVASTACK® 35-P RECEPTACLE ASS'Y	10:1	A3	14
13	Z190514	R.S	2019/04/12	TAK	6 MAX.	±0.2	30 OVER 120 MAX.	±0.5				UNIT		
12	Z180678	R.H	2018/05/28	TAK	GENERAL TOLERANCE.									
11	Z171526	Y.B	2017/12/27	TAK	DWG.	T.Hirakawa	DATE	2015/08/15						
10	Z171285	T.F	2017/11/08	TAK	CHK.	T.Tagawa								
9	Z171019	T.F	2017/09/04	TAK	APP.	E.Kawabe								
REVISION RECORD										DWG. No.	20709	SIZE	1/6	

ITEMS	SPECIFICATION	
	NORMAL CONDUCTIVITY	HIGH CONDUCTIVITY
APPLICABLE CONNECTOR PART No.	20708-0**E-**	
RATING VOLTAGE	50V AC (r.m.s) / DC	
RATING AMPERAGE (FOR SIGNAL CONTACT)	0.3A AC/DC (PER CONTACT PIN), 12.0A AC/DC(TOTAL)	0.3A AC/DC (PER CONTACT PIN), 12.0A AC/DC(TOTAL) 1.0A AC/DC (PER CONTACT OF UP TO 8 PINS)
RATING AMPERAGE (FOR POWER CONTACT)	2.0A AC/DC (PER CONTACT PIN), 4.0A AC/DC(TOTAL)	
OPERATING TEMPERATURE	233~358K(-40°C~+85°C)	
OPERATING HUMIDITY	85% MAX.(NON-CONDENSING)	
CONTACT RESISTANCE (FOR SIGNAL CONTACT)	INITIAL : 80mohm MAX. / AFTER TEST : \triangleleft 20mohm MAX.	INITIAL : 30mohm MAX. / AFTER TEST : \triangleleft 20mohm MAX.
CONTACT RESISTANCE (FOR POWER CONTACT)	INITIAL : 80mohm MAX. / AFTER TEST : \triangleleft 20mohm MAX.	INITIAL : 30mohm MAX. / AFTER TEST : \triangleleft 20mohm MAX.
INSULATION RESISTANCE	INITIAL : 1,000Mohm MIN. / AFTER TEST : 500Mohm MIN.	
DIELECTRIC WITHSTANDING VOLTAGE	AC200V 1min	
DURABILITY	20 CYCLES	
MATING FORCE (INITIAL)	1.0 N/Pin MAX.	~28P 2.0 N/Pin MAX. 30P~ 1.0 N/Pin MAX.
UNMATING FORCE (AFTER TEST)	0.15 N/Pin MIN.	~28P 0.30 N/Pin MIN. 30P~ 0.15 N/Pin MIN.
COPLANARITY	0.08 MAX.	
PRODUCT SPECIFICATION	PRS-2101	PRS-2334
TEST REPORT	TR-15069	TR-16143
PACKING STANDARD	PST-15077 (20K/REEL) PST-17039 (5K/REEL)	
INSTRUCTION MANUAL	HIM-15014	
APPEARANCE CRITERIA No.	QLS-A***	

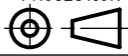
ANGLE	$\pm 2^\circ$	6 OVER 30 MAX.	± 0.3	PROJECTION 	SERIES No. R2	CUSTOMER COPY		
6 MAX.	± 0.2	30 OVER 120 MAX.	± 0.5					
GENERAL TOLERANCE.				TITLE NOVASTACK® 35-P RECEPTACLE ASS'Y	SCALE	I-PEX		
DWG.	DATE							
CHK.								
APP.								
DWG. No.	20709			SIZE	SHEET	REV.		
				A3	2/6	14		

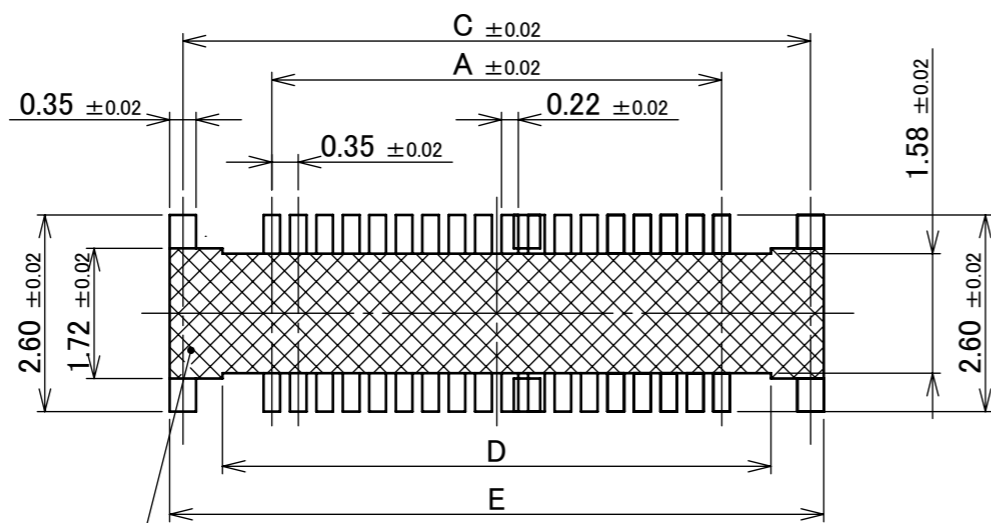

半田上がり防止の為、半田付けをしないで下さい。
 パターンを設けるときは、レジストを設けて下さい。
 MUST BE NOT SOLDERING AREA FOR PREVENT FROM SOLDER WICKING.
 MUST BE RESIST COATING ON THE PATTERN.

RECOMMENDED PATTERN LAYOUT

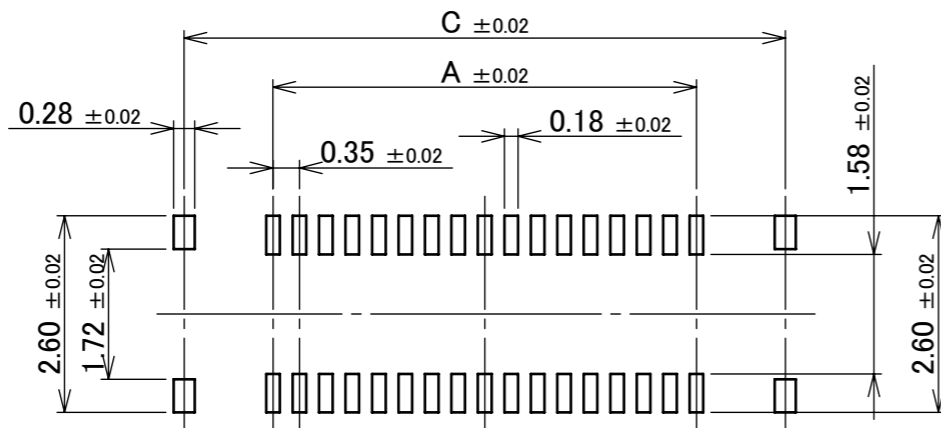

RECOMMENDED METAL MASK LAYOUT
 THICKNESS : 0.10 mm

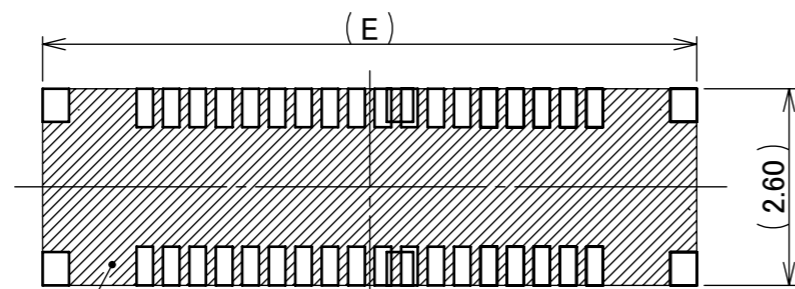

NOTE. 1

NOTES.
 1. THIS AREA CANNOT MOUNT ANOTHER COMPONENTS.

ホールドダウンを電源用としてご使用の場合は、
 両パットを図のように繋げて下さい。
 PAD IS CONNECTED LIKE FIGURE WHEN HOLD DOWN
 IS USED FOR POWER SUPPLY.

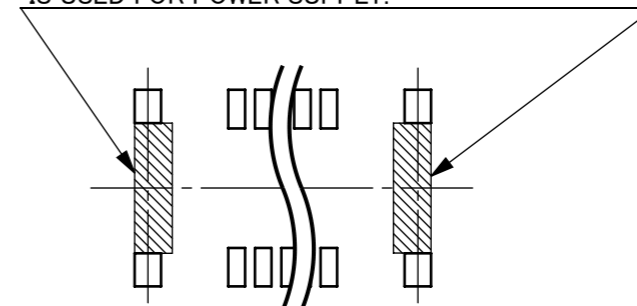

HOLD DOWN PAD LAYOUT
 USED FOR POWER SUPPLY

ANGLE	±2°	6 OVER 30 MAX.	±0.3	PROJECTION ⊕	SERIES No. R2	CUSTOMER COPY			
	6 MAX.	±0.2	30 OVER 120 MAX.						±0.5
GENERAL TOLERANCE.				TITLE		SCALE	I-PEX		
DWG.	DATE			NOVASTACK® 35-P RECEPTACLE ASS'Y		5:1			
CHK.						UNIT			
APP.						mm			
				DWG. No.	20709	SIZE	SHEET	REV.	
						A3	3/6	14	

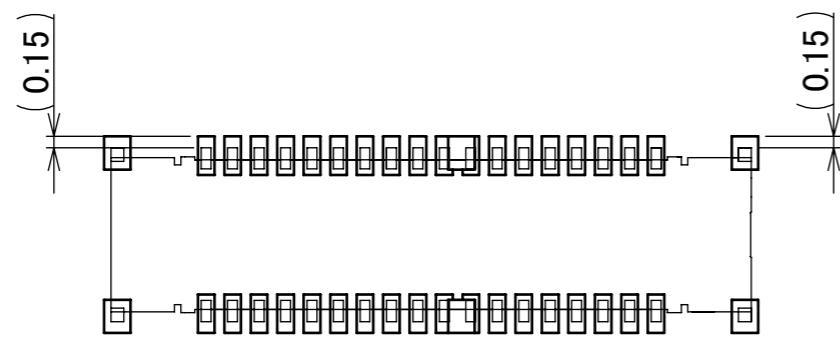

CONNECTOR ON RECOMMENDED FOOTPRINT PATTERN

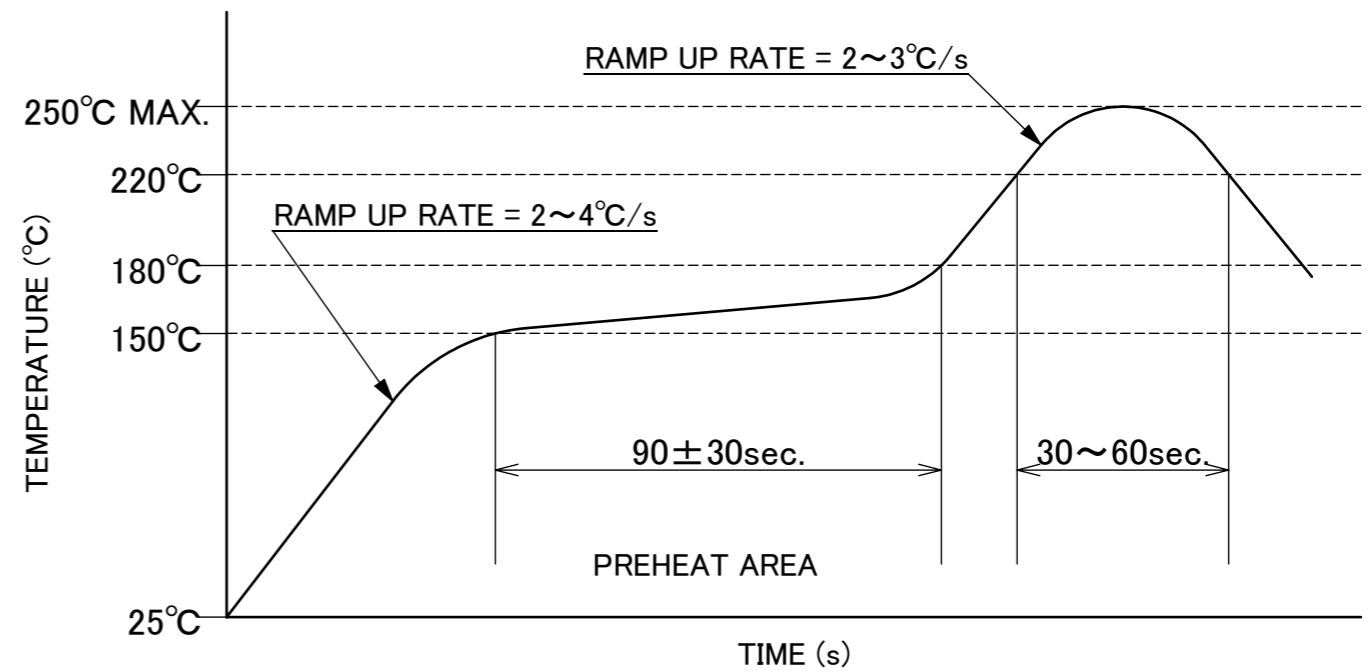

REFLOW TEMPERATURE PROFILE
 SENJU METAL INDUSTRY CO., LTD. : M705-SHF(Sn96.5 Ag3.0 Cu0.5)

ANGLE	±2°	6 OVER 30 MAX.	±0.3	PROJECTION 	SERIES No. R2	CUSTOMER COPY		
6 MAX.	±0.2	30 OVER 120 MAX.	±0.5					
GENERAL TOLERANCE.				TITLE NOVASTACK® 35-P RECEPTACLE ASS'Y	SCALE 10:1	UNIT I-PEX		
DWG.	DATE							
CHK.								
APP.								
				DWG. No.	20709	SIZE	SHEET	REV.
						A3	4/6	14

PART NO.	Pos.	G	H	QTY. PER EMBOSS REEL (PIECES / REEL)	QTY. PER PACKING CARTON (REELS / CARTON)
20709-0**E-##	10~14P	12	5.5	20,000 / REEL	20,000 × 9 REELS = 180,000
	16~36P	16	7.5		20,000 × 7 REELS = 140,000
	38~70P	24	11.5		20,000 × 5 REELS = 100,000

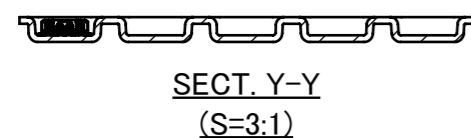
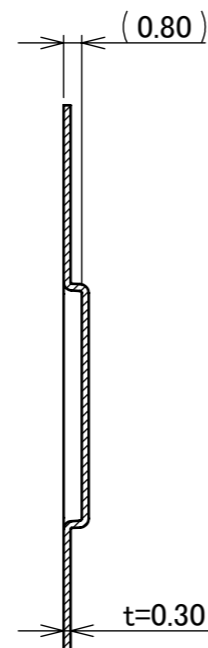
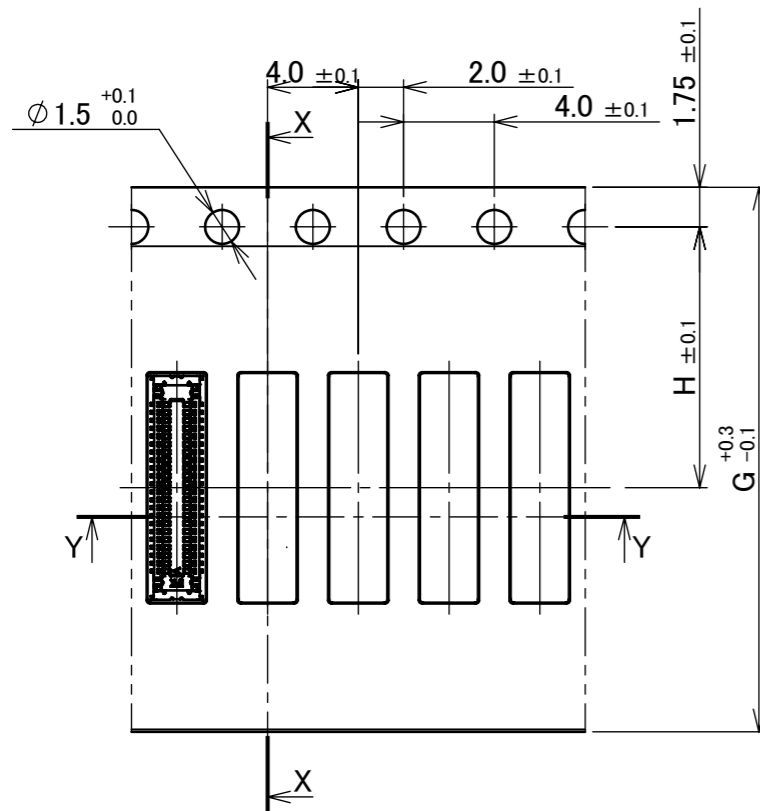
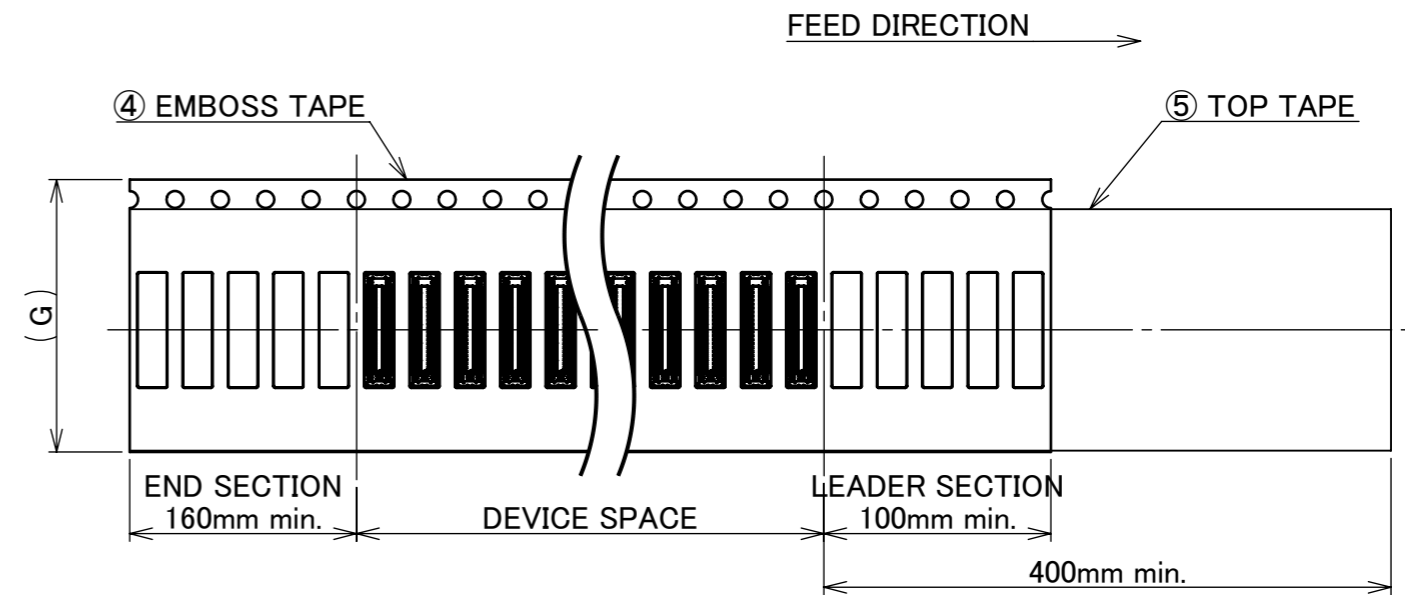
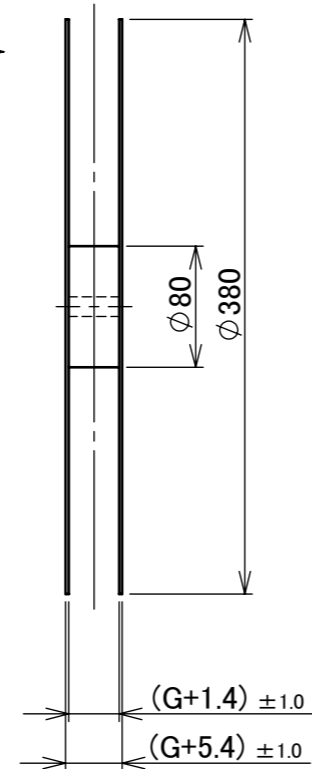
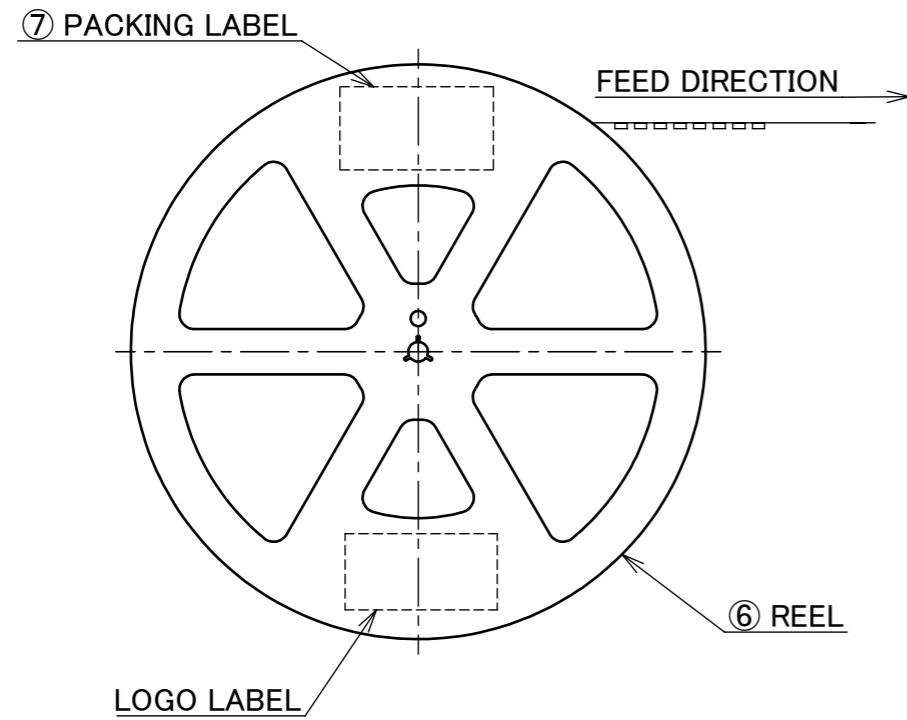

- NOTES.
2. TAPING SPECIFICATION FOLLOWS JIS C 0806 (IEC 60286-3).
3. MAKE EMPTY SECTION OF LEADER AND END ON EACH END OF THE TAPE.
4. TOP TAPE SHALL NOT STICK OUT FROM EMBOSS TAPE.
5. TOP TAPE SHALL NOT COVER FEED HOLE.

NO.	DISCRIPTION	MATERIAL	FINISH , REMARKS
7	PACKING LABEL	-	-
6	REEL	PS	ANTI-STATIC TYPE BLACK
5	TOP TAPE	PET t=0.062 TRANSPARENCY	ANTI-STATIC TYPE
4	EMBOSS TAPE	TRANSPARENCY	ANTI-STATIC TYPE

ANGLE	±2°	6 OVER 30 MAX.	±0.3	PROJECTION	SERIES No.	CUSTOMER COPY			
6 MAX.	±0.2	30 OVER 120 MAX.	±0.5		R2				
GENERAL TOLERANCE.				TITLE	NOVASTACK® 35-P RECEPTACLE ASS'Y		SCALE	1:X	
DWG.	DATE			CHK.	DWG. No. 20709		UNIT	mm	
APP.						SIZE	SHEET	REV.	
							A3	5/6	14

PART NO.	Pos.	J	K	QTY. PER EMBOSS REEL (PIECES / REEL)	QTY. PER PACKING CARTON (REELS / CARTON)
20709-0**E-##-M	10~14P	12	5.5	5,000 / REEL	5,000 × 9 REELS = 45,000
	16~36P	16	7.5		5,000 × 7 REELS = 35,000
	38~70P	24	11.5		5,000 × 5 REELS = 25,000

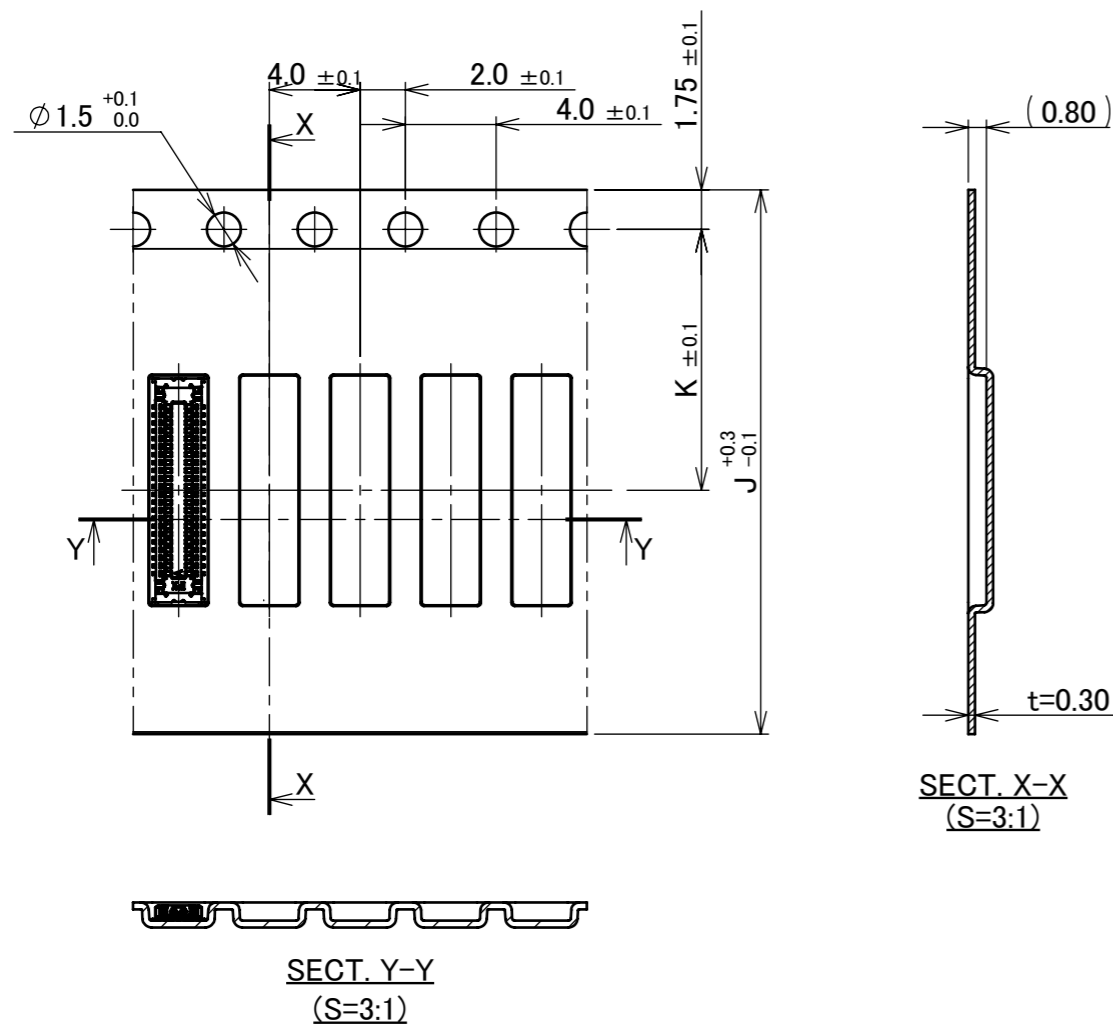
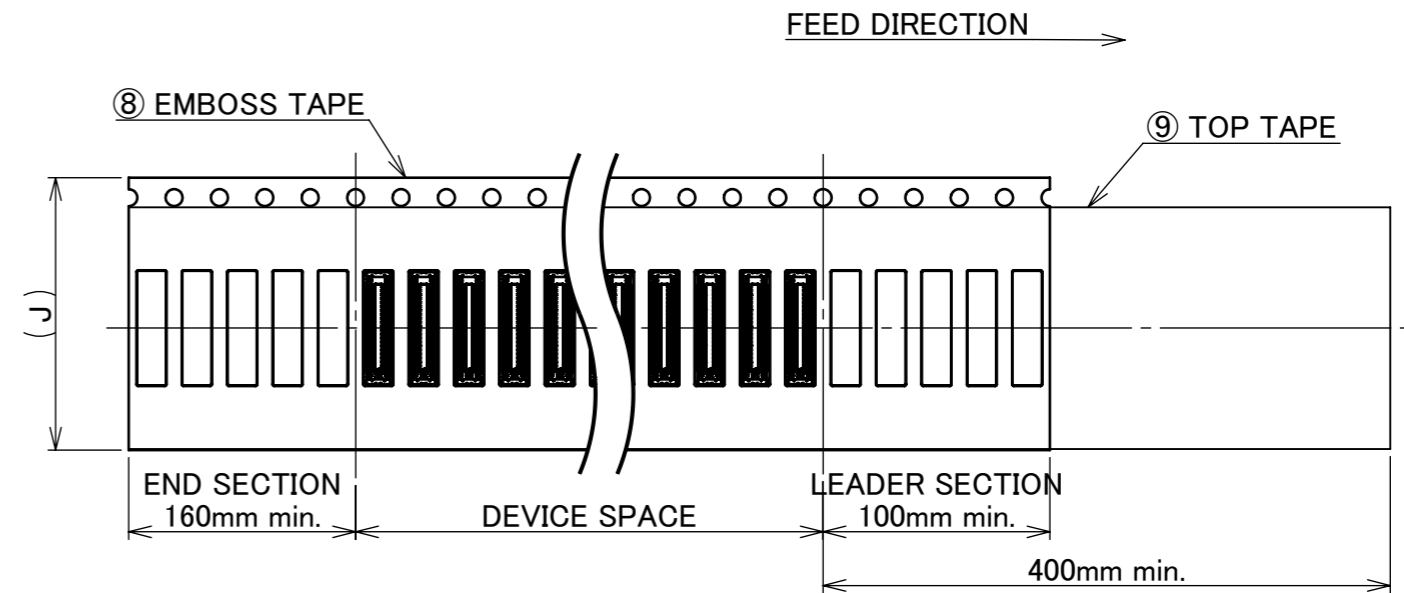
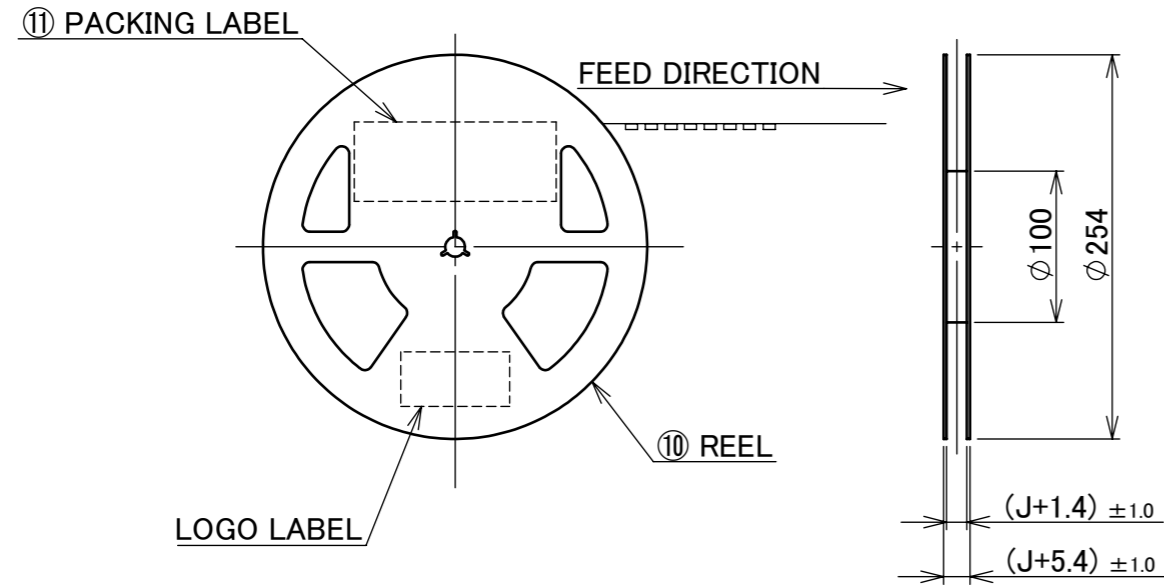

- NOTES.
- TAPING SPECIFICATION FOLLOWS JIS C 0806 (IEC 60286-3).
 - MAKE EMPTY SECTION OF LEADER AND END ON EACH END OF THE TAPE.
 - TOP TAPE SHALL NOT STICK OUT FROM EMBOSS TAPE.
 - TOP TAPE SHALL NOT COVER FEED HOLE.

NO.	DISCRIPTION	MATERIAL	FINISH , REMARKS
11	PACKING LABEL	-	-
10	REEL	PS	ANTI-STATIC TYPE BLACK
9	TOP TAPE	PET t=0.062 TRANSPARENCY	ANTI-STATIC TYPE
8	EMBOSS TAPE	TRANSPARENCY	ANTI-STATIC TYPE

ANGLE	±2°	6 OVER 30 MAX.	±0.3	PROJECTION ①	SERIES No. R2	CUSTOMER COPY			
6 MAX.	±0.2	30 OVER 120 MAX.	±0.5						
GENERAL TOLERANCE.				TITLE		SCALE	I-PEX		
DWG.	DATE			NOVASTACK® 35-P RECEPTACLE ASS'Y		1:X			
CHK.						UNIT			
APP.						mm			
				DWG. No.	20709	SIZE	SHEET	REV.	
						A3	6/6	14	