

\*编号: GH-ZD4132E

版本号: 2



广东风华高新科技股份有限公司  
GUANGDONG FENGHUA ADVANCED TECHNOLOGY HOLDING CO., LTD.

# 承 认 书

## APPROVAL SHEET

客户名称

**CUSTOMER :** \_\_\_\_\_

产品名称

多层片状陶瓷电容器

**PART NAME:** MULTILAYER CERAMIC CAPACITORS

规格

**SPECIFICATION:** 0201~2225TYPE

版本

**VERSION:** \_\_\_\_\_

日期

**DATE OF ISSUE:** \_\_\_\_\_

制 造 MANUFACTURER			客 户 CUSTOMER		
拟制 DESIGN	审核 CHECK	批准 APPROVAL	检验 INSPECTOR	审核 CHECK	批准 APPROVAL



## 一、概述

### ●电容器及介质种类:

※高频类: 此类介质材料的电容器为 I 类电容器, 包括通用型高频 COG、COH 电容器和温度补偿型高频 HG、LG、PH、RH、SH、TH、UJ、SL 电容器。其中 COG、COH 电容器电性能最稳定, 几乎不随温度、电压和时间的变化而变化, 适用于低损耗, 稳定性要求高的高频电路, HG、LG、PH、RH、SH、TH、UJ、SL 电容器容量随温度变化而相应变化, 适用于低损耗、温度补偿型电路中。

※ X7R、X5R、X7S、X6S: 此类介质材料的电容器为 II 类电容器, 具有较高的介电常数, 容量比 I 类电容器高, 具有较稳定的温度特性, 适用于容量范围广, 稳定性要求不高的电路中, 如隔直、耦合、旁路、鉴频等电路中。

※Y5V: 此类介质材料的电容器为 II 类电容器, 是所有电容器中介电常数最大的电容器, 但其容量稳定性较差, 对温度、电压等条件较敏感, 适用于要求大容量, 温度变化不大的电路中。

※Z5U: 此类介质材料的电容器为 II 类电容器, 其温度特性介于 X7R 和 Y5V 之间, 容量稳定性较差, 对温度、电压等条件较敏感, 适用于要求大容量, 使用温度范围接近于室温的旁路, 耦合等, 低直流偏压的电路中。

## SUMMARY

### ●Types of Dielectric Material and Capacitor

※HIGH FREQUENCY TYPE: The capacitor of this kind dielectric material is considered as Class I capacitor, including high frequency COG、COH capacitor and temperature compensating capacitor such as HG, LG, PH, RH,SH, TH, UJ, SL. The electrical properties of COG、COH capacitor are the most stable one and change invariably with temperature, voltage and time. They are suited for applications where low-losses and high-stability are required, HG, LG, PH, RH, SH, TH, UJ, SL capacitor's capacitance changes with temperature. They are suited for applications where low-losses and temperature compensating circuits.

※X7R、X5R、X7S、X6S: X7R、X5R、X7S、X6S material is a kind of material has high dielectric constant. The capacitor made of this kind material is considered as Class II capacitor whose capacitance is higher than that of class I. These capacitors are classified as having a semi-stable temperature characteristic and used over a wide temperature range, such in these kinds of circuits, DC-blocking, decoupling, bypassing, frequency discriminating etc.

※Y5V: The capacitor made of this kind of material is the highest dielectric constant of all ceramic capacitors. They are used over a moderate temperature range in application where high capacitance is required because of its unstable temperature coefficient, but where moderate losses and capacitance changes can be tolerated. Its capacitance and dissipation factors are sensible to measuring conditions, such as temperature and voltage, etc.

※Z5U: The capacitor made of this kind of material is considered as Class II capacitor, whose temperature characteristic is between that of X7R and Y5V. The capacitance of this kind of capacitor is unstable and sensible to temperature and voltage. Ideally suited for bypassing and decoupling application circuits operating with low DC bias in the environment approaches to room temperature.



## 二、尺寸及结构 DIMENSIONS AND STRUCTURE

※ 尺寸 DIMENSIONS



● ≤50V 通用产品

型号 Type		介质种类 Dielectric	尺寸 Dimensions (mm)				特别说明 Special Instructions
英制表示 British expression	公制表示 Metric expression		L	W	T	WB	
1005	0402	所有介质 All Dielectric	$0.4 \pm 0.02$	$0.2 \pm 0.02$	$0.2 \pm 0.02$	$0.1 \pm 0.03$	All
*0201	0603	所有介质 All Dielectric	$0.6 \pm 0.03$	$0.3 \pm 0.03$	$0.3 \pm 0.03$	$0.15 \pm 0.05$	$C < 220\text{nF}$
			$0.6 \pm 0.05$	$0.3 \pm 0.05$	$0.3 \pm 0.05$	$0.15 \pm 0.05$	$C \geq 220\text{nF}$
*0402	1005	Y5V/Z5U	$1.00 \pm 0.05$	$0.50 \pm 0.05$	$0.50 \pm 0.05$	$0.20 \pm 0.05$	$C \leq 0.47\mu\text{F}$
			$1.00 \pm 0.15$	$0.50 \pm 0.10$	$0.50 \pm 0.10$	$0.20 \pm 0.05$	$0.47\mu\text{F} < C \leq 1\mu\text{F}$
		除 Y5V/Z5U 外	$1.00 \pm 0.05$	$0.50 \pm 0.05$	$0.50 \pm 0.05$	$0.20 \pm 0.05$	$C < 1\mu\text{F}$
			$1.00 \pm 0.15$	$0.50 \pm 0.15$	$0.50 \pm 0.15$	$0.20 \pm 0.05$	$1\mu\text{F} \leq C < 10\mu\text{F}$
			$1.00 \pm 0.20$	$0.50 \pm 0.20$	$0.50 \pm 0.20$	$0.20 \pm 0.05$	$C \geq 10\mu\text{F}$
0603	1608	所有材料 All Dielectric	$1.60 \pm 0.10$	$0.80 \pm 0.10$	$0.80 \pm 0.10$	$0.30 \pm 0.10$	$C < 10\mu\text{F}$
			$1.60 \pm 0.20$	$0.80 \pm 0.20$	$0.80 \pm 0.20$	$0.30 \pm 0.10$	$C \geq 10\mu\text{F}$
0805	2012	Y5V/Z5U	$2.00 \pm 0.20$	$1.25 \pm 0.20$	$0.70 \pm 0.10$	$0.50 \pm 0.20$	$C \leq 0.22\mu\text{F}$
			$2.00 \pm 0.20$	$1.25 \pm 0.20$	$0.80 \pm 0.10$	$0.50 \pm 0.20$	$0.22\mu\text{F} < C \leq 2.2\mu\text{F}$
			$2.00 \pm 0.20$	$1.25 \pm 0.20$	$1.25 \pm 0.20$	$0.50 \pm 0.20$	$2.2\mu\text{F} < C \leq 10\mu\text{F}$



● ≤50V 通用产品

型号 Type		介质种类 Dielectric	尺寸 Dimensions (mm)				特别说明 Special Instructions
英制表示 British expression	公制表示 Metric expression		L	W	T	WB	
*0805	2012	除 Y5V/Z5U 外	2.00±0.20	1.25±0.20	0.80±0.20	0.50±0.20	C≤2.2uF
			2.00±0.20	1.25±0.20	1.25±0.20	0.50±0.20	C≥0.47uF
*1206	3216	Y5V/Z5U	3.20±0.30	1.60±0.30	0.80±0.20	0.60±0.30	C≤10uF
			3.20±0.30	1.60±0.30	1.60±0.30	0.60±0.30	C>10uF
		除 Y5V/Z5U 外	3.20±0.30	1.60±0.30	0.80±0.20	0.60±0.30	C≤330nF
			3.20±0.30	1.60±0.30	1.00±0.20	0.60±0.30	330nF<C<470nF
			3.20±0.30	1.60±0.30	1.25±0.20	0.60±0.30	470nF≤C<3.3uF
			3.20±0.30	1.60±0.30	1.60±0.30	0.60±0.30	C≥3.3uF
1210	3225	所有介质 All Dielectric	3.20±0.30	2.50±0.30	≤2.80	0.60±0.30	All
1808	4520	所有介质 All Dielectric	4.50±0.40	2.00±0.20	≤2.20	0.60±0.30	All
1812	4532	所有介质 All Dielectric	4.50±0.40	3.20±0.30	≤3.50	0.60±0.30	All
2220	5750	所有介质 All Dielectric	5.70±0.40	5.00±0.40	≤3.50	0.60±0.30	All
2225	5763	所有介质 All Dielectric	5.70±0.50	6.30±0.50	≤6.20	0.60±0.30	All

备注：1、产品具体厚度“T”查阅本承认书中“容量范围及其电压”。

2、可根据客户的特殊要求设计符合客户需求的产品。

Note: 1、The specific thickness of the product can read "capacity range and voltage" in this approval sheet.

2、We can design according to customer special requirements



● >50V 中高压产品

型号 Type		尺寸 Dimensions (mm)			
英制表示 British expression	公制表示 Metric expression	L	W	T	WB
*0402	1005	1.00±0.05	0.50±0.05	0.50±0.05	0.20±0.05
0603	1608	1.60±0.10	0.80±0.10	0.80±0.10	0.30±0.10
0805	2012	2.00±0.20	1.25±0.20	≤0.55 0.80±0.20 1.00±0.20 1.25±0.20	0.50±0.20
1206	3216	3.20±0.30	1.60±0.30	0.80±0.20 1.00±0.20 1.25±0.20 1.60±0.30	0.60±0.30
1210	3225	3.20±0.30	2.50±0.30	≤2.80	0.60±0.30
1808	4520	4.50±0.40	2.00±0.20	≤2.20	0.60±0.30
1812	4532	4.50±0.40	3.20±0.30	≤3.50	0.60±0.30
2220	5750	5.70±0.40	5.00±0.40	≤3.50	0.60±0.30
2225	5763	5.70±0.50	6.30±0.50	≤6.20	0.60±0.30

备注：1、产品具体厚度“T”查阅本承认书中“容量范围及其电压”。

2、可根据客户的特殊要求设计符合客户需求的产品。

Note: 1、The specific thickness of the product can read "capacity range and voltage" in this approval sheet.

2、We can design according to customer special requirements

※ 结构 STRUCTURE



序号 NO	名称 Name
①	陶瓷介质 Ceramic dielectric
②	内电极 Inner electrode
③	外电极 Substrate electrode
④	镍层 Nickel Layer
⑤	锡层 Tin Layer



### 三、型号规格表示方法 HOW TO ORDER

<u>0805</u>	<u>CG</u>	<u>101</u>	<u>J</u>	<u>500</u>	<u>N</u>	<u>T</u>
①	②	③	④	⑤	⑥	⑦

#### ※说明 NOTES:

#### ①尺寸 DIMENSIONS

尺寸规格 Size Code	1005	0201	0402	0603	0805	1206	1210	1808	1812	2220	2225
长×宽 (L×W) inch	001 × 0005	002 × 001	004 × 002	006 × 003	008 × 005	012 × 006	012 × 010	018 × 008	018 × 012	022 × 020	022 × 025
长×宽 (L×W) mm	040 × 020	060 × 030	100 × 050	160 × 080	200 × 125	320 × 160	320 × 250	450 × 200	450 × 320	570 × 500	570 × 630

#### ② 介质种类 DIELECTRIC STYLE

介质种类 (Dielectric Code)	CG	CH	HG	LG	PH	RH	SH	TH	UJ	SL	X	B	BS	DS	E	F
介质材料 (Dielectric)	CO G	CO H	HG	LG	PH	RH	SH	TH	UJ	SL	X5 R	X7 R	X7 S	X6 S	Z5 U	Y5 V

#### ③ 标称容量 NOMINAL CAPACITANCE

单位(unit): pF

表示方式 (Express Method)	实际值 (Actual Value)	注：头两位数字为有效数字，第三位数字为 0 的个数；R 为小数点。 Note: the first two digits are significant; third digit denotes number of zeros; R=decimal point.
0R5	0.5	
1R0	1.0	
102	$10 \times 10^2$	
224	$22 \times 10^4$	
...	...	

#### ④ 容量误差 CAPACITANCE TOLERANCE

代码 (Code)	A	B	C	D	F	G	J	K	M	S	Z
误差 (Tolerance)	± 0.05pF	± 0.10pF	± 0.25pF	± 0.5pF	± 1.0%	± 2.0%	± 5.0%	±10%	±20%	+50% -20%	+80% -20%

备注：A、B、C、D 级误差适用于容量 ≤ 10pF 的产品。

Note: These capacitance tolerance A, B, C, D are just applicable the capacitance that equals to or less than 10pF.



⑤ 额定电压 RATED VOLTAGE

单位(unit): V

表示方式 (Express Method)	实际值 (Actual Value)	注: 头两位数字为有效数字, 第三位数字为 0 的个数; R 为小数点。 Note: the first two digits are significant; third digit denotes number of zeros; R=decimal point.
6R3	6.3	
500	$50 \times 10^0$	
201	$20 \times 10^1$	
102	$10 \times 10^2$	
...	...	

⑥ 端头材料 TERMINAL MATERIAL STYLES

端头类别 (Termination Styles)	表示方式 (Express Method)
纯银端头 (Silver Solderable Termination)	S
纯铜端头 (Copper Solderable Termination)	C
三层电镀端头 (Nickel Barrier Termination)	N

⑦ 包装方式 PACKAGE STYLES

B	T
散包装 (Bulk Bag)	编带包装 (Taping Package)

四、温度系数/特性 Temperature Coefficient /Characteristics

介质种类 Dielectric	参考温度点 Reference Temperature Point	标称温度系数 Temperature Coefficient	工作温度范围 Operation Temperature Range
COG	20°C	0±30 ppm/°C	-55°C ~ 125°C
COH	20°C	0±60 ppm/°C	-55°C ~ 125°C
HG	20°C	-33±30 ppm/°C	-25°C ~ 85°C
LG	20°C	-75±30 ppm/°C	-25°C ~ 85°C
PH	20°C	-150± 60 ppm/°C	-25°C ~ 85°C
RH	20°C	-220± 60 ppm/°C	-25°C ~ 85°C
SH	20°C	-330± 60 ppm/°C	-25°C ~ 85°C
TH	20°C	-470± 60 ppm/°C	-25°C ~ 85°C
UJ	20°C	-750± 120 ppm/°C	-25°C ~ 85°C
SL	20°C	-1000~+140 ppm/°C	-25°C ~ 85°C
X7R	20°C	±15%	-55°C ~ 125°C
X5R	20°C	±15%	-55°C ~ 85°C
X7S	20°C	±22%	-55°C ~ 125°C
X6S	20°C	±22%	-55°C ~ 105°C
Z5U	20°C	-56%~+22%	10°C ~ 85°C
Y5V	20°C	-80%~+30%	-25°C ~ 85°C

备注: I 类电容器标称温度系数和允许偏差是采用温度在 20°C 和 85°C 之间的电容量变化来确定的, 而 II 类电容器标称温度系数是按照工作范围之间的电容量相对 20°C 的电容量变化来确定的。

Note: Nominal temperature coefficient and allowed tolerance of class I are decided by the changing of the capacitance between 20°C and 85°C. Nominal temperature coefficient of class II are decided by the temperature of 20°C.



## 五、容量范围及其电压 Capacitance Range and Operating Voltage

备注：1、【】对应容量的通用厚度，单位：mm

2、可根据客户的特殊要求设计符合客户需求的产品

Note: 1、【】 General thickness corresponds to the capacity, unit: mm

2、We can design according to the customer requirements.

尺寸规格 Size Code	额定电压 Rated Voltage	容量范围 Capacitance	
		COG(NPO)(PF)	Y5V (Z5U)(PF)
1005	6.3V	—	—
	10V	0.1~220 【0.2】	—
	16V	0.1~100 【0.2】	—
	25V	0.1~100 【0.2】	—
	50V	—	—
0201	6.3V	—	10,000~100,000 【0.3】
	10V	—	—
	16V	—	10,000 【0.3】
	25V	0.1~1,000 【0.3】	—
	50V	0.1~220 【0.3】	—
0402	6.3V	3,300~4,700 【0.5】	1,000~1,000,000 【0.5】
	10V	1,200~2,700 【0.5】	1,000~1,000,000 【0.5】
	16V	1,200~2,700 【0.5】	1,000~220,000 【0.5】
	25V	0.1~1,200 【0.5】	1,000~220,000 【0.5】
	50V	0.1~1,000 【0.5】	1,000~100,000 【0.5】
0603	6.3V	—	2,700,000~10,000,000 【0.8】
	10V	12,000~22,000 【0.8】	2,700,000~10,000,000 【0.8】
	16V	8,200~10,000 【0.8】	1,000~2,200,000 【0.8】
	25V	0.1~6,800 【0.8】	1,000~2,200,000 【0.8】
	50V	0.1~6,800 【0.8】	1,000~1,000,000 【0.8】





尺寸规格 Size Code	额定电压 Rated Voltage	容量范围 Capacitance	
		COG(NPO)(PF)	Y5V (Z5U)(PF)
0805	6.3V	—	2,700,000~22,000,000 【0.8】
	10V	10,000~100,000 【1.25】	2,700,000~22,000,000 【0.8】
	16V	10,000~33,000 【1.25】	2,700,000~10,000,000 【0.8】
	25V	10,000~27,000 【1.25】	2,700,000~4,700,000 【0.8】
	50V	0.1~8,200 【0.8】 10,000~22,000 【1.25】	1,000~2,200,000 【0.8】
1206	6.3V	—	22,000,000~47,000,000 【1.6】
	10V	—	22,000,000 【1.6】
	16V	—	22,000,000 【1.6】
	25V	—	4,700,000~10,000,000 【0.8】
	50V	0.3~8,200 【0.8】 10,000~100,000 【1.6】	1,000~4,700,000 【0.8】
1210	6.3V	—	10,000,000~100,000,000 【2】
	10V	—	10,000,000~47,000,000 【2】
	16V	—	10,000,000~22,000,000 【2】
	25V	—	6,800,000~10,000,000 【1.25】
	50V	10~100,000 【1.25】	4,700~4,700,000 【1.25】
1808	50V	10~100,000 【1.6】	—
1812	6.3V	—	10,000~100,000,000 【1.6】
	10V	—	10,000~100,000,000 【1.6】
	16V	—	10,000~22,000,000 【1.6】
	25V	—	10,000~10,000,000 【1.6】
	50V	10~100,000 【1.25】	10,000~10,000,000 【1.6】



尺寸规格 Size Code	额定电压 Rated Voltage	容量范围 Capacitance			
		X7R (nF)	X7S(uF)	X5R(uF)	X6S(uF)
1005	4V/6.3V	—	—	0.015uF~0.1uF【0.2】	—
	10V/16V	0.1~1【0.2】	—	0.015uF~0.01uF【0.2】	—
*0201	4V	—	0.01~1【0.3】	0.015uF~2.2uF【0.3】	0.015uF~2.2uF【0.3】
	6.3V	—	0.01~0.22【0.3】	0.015uF~2.2uF【0.3】	0.015uF~2.2uF【0.3】
	10V	0.1~22【0.3】	0.01~0.22【0.3】	0.015uF~1uF【0.3】	0.015uF~0.22uF【0.3】
	16V	0.1~22【0.3】	—	0.015uF~0.22uF【0.3】	0.015uF~0.1uF【0.3】
	25V	0.1~10【0.3】	—	0.015uF~0.1uF【0.3】	0.015uF~0.1uF【0.3】
	50V	0.1~1【0.3】	—	0.0047uF~0.01uF【0.3】	—
*0402	4V	—	—	0.1uF~10uF【0.5】	0.1uF~10 uF【0.5】
	6.3V	0.1~470【0.5】	0.1~0.47【0.5】	0.1uF~10uF【0.5】	0.1uF~10 uF【0.5】
	10V	0.1~470【0.5】	0.1~0.47【0.5】	0.1uF~4.7uF【0.5】	0.1uF~2.2 uF【0.5】
	16V	0.1~220【0.5】	0.047~0.22【0.5】	0.1uF~2.2 uF【0.5】	0.1uF~2.2 uF【0.5】
	25V	0.1~220【0.5】	0.022~0.1【0.5】	0.1uF~2.2 uF【0.5】	0.1uF~1 uF【0.5】
	50V	0.1~100【0.5】	0.0047~0.1【0.5】	0.047uF~1uF【0.5】	—
0603	4V	—	—	0.47uF~22uF【0.8】	0.1uF~22 uF【0.8】
	6.3V	0.15~4,700【0.8】	0.47~2.2【0.8】	0.47uF~22uF【0.8】	0.1uF~22 uF【0.8】
	10V	0.15~2,200【0.8】	0.47~2.2【0.8】	0.47uF~22uF【0.8】	0.1uF~10 uF【0.8】
	16V	0.15~2,200【0.8】	0.47~1【0.8】	0.47uF~10uF【0.8】	0.1uF~10 uF【0.8】
	25V	0.15~1,000【0.8】	0.47~1【0.8】	0.47uF~10uF【0.8】	0.1uF~4.7 uF【0.8】
	50V	0.15~1,000【0.8】	—	0.47uF~2.2uF【0.8】	—
**0805	4V	—	—	1~47【1.25】	0.1~0.47【0.8】 0.56~47【1.25】
	6.3V	0.15~470【0.8】 560~10,000【1.25】	1~10【1.25】	1~47【1.25】	0.1~0.47【0.8】 0.56~47【1.25】
	10V	0.15~470【0.8】 560~10,000【1.25】	1~10【1.25】	1~22【1.25】	0.1~0.47【0.8】 0.56~22【1.25】
	16V	0.15~470【0.8】 560~10,000【1.25】	1~4.7【1.25】	1~22【1.25】	0.1~0.47【0.8】 0.56~10【1.25】



尺寸规格 Size Code	额定电压 Rated Voltage	容量范围 Capacitance			
		X7R (nF)	X7S (uF)	X5R(uF)	X6S(uF)
0805	25V	0.15~470 【0.8】 560~4,700 【1.25】	1~4.7 【1.25】	1~22 【1.25】	0.1~0.47 【0.8】 0.56~10 【1.25】
	50V	0.15~470 【0.8】 560~2,200 【1.25】	—	1~4.7 【1.25】	—
*1206	4V	—	2.2~3.3 【1.25】 4.7~150 【1.6】	0.1uF~1.8uF 【0.8】 2.2uF~3.3uF 【1.25】 4.7~100uF 【1.6】	2.2~3.3 【1.25】 4.7~100 【1.6】
	6.3V	0.2~330 【0.8】 470~3,300 【1.25】 4,700~22,000【1.6】	2.2~3.3 【1.25】 4.7~22 【1.6】	2.2~3.3 【1.25】 4.7~47 【1.6】	0.1uF~1.8uF 【0.8】 2.2uF~3.3uF 【1.25】 4.7~100uF 【1.6】
	10V	0.2~330 【0.8】 470~3,300 【1.25】 4,700~22,000【1.6】	2.2~3.3 【1.25】 4.7~22 【1.6】	2.2~3.3 【1.25】 4.7~47 【1.6】	0.1uF~1.8uF 【0.8】 2.2uF~3.3uF 【1.25】 4.7~22uF 【1.6】
	16V	0.2~330 【0.8】 470~3,300 【1.25】 4,700~10,000【1.6】	1~1.8 【0.8】 2.2~3.3 【1.25】 4.7~10 【1.6】	2.2~3.3 【1.25】 4.7~22 【1.6】	0.1uF~1.8uF 【0.8】 2.2uF~3.3uF 【1.25】 4.7~22uF 【1.6】
	25V	0.2~330 【0.8】 470~3,300 【1.25】 4,700~10,000【1.6】	1~1.8 【0.8】 2.2~3.3 【1.25】 4.7~10 【1.6】	2.2~3.3 【1.25】 4.7~22 【1.6】	0.1uF~1.8uF 【0.8】 2.2uF~3.3uF 【1.25】 4.7~10uF 【1.6】
	50V	0.2~330 【0.8】 470~3,300 【1.25】 4,700 【1.6】	1~1.8 【0.8】 2.2~3.3 【1.25】 4.7 【1.6】	2.2~3.3 【1.25】 4.7~10 【1.6】	—



尺寸规格 Size Code	额定电压 Rated Voltage	容量范围 Capacitance			
		X7R (nF)	X7S (uF)	X5R(uF)	X6S(uF)
1210	4V	—	—	4.7uF~10uF【1.6】 12uF~330uF【2.5】	0.1uF~0.47uF【1.25】 0.56uF~10uF【1.6】 12uF~330uF【2.5】
	6.3V	0.22~470【1.25】 560~47,000【1.6】	4.7uF~10uF【1.6】 12uF~100uF【2.5】	4.7uF~10uF【1.6】 12uF~330uF【2.5】	0.1uF~0.47uF【1.25】 0.56uF~10uF【1.6】 12uF~100uF【2.5】
	10V	0.22~470【1.25】 560~47,000【1.6】	—	4.7uF~10uF【1.6】 12uF~100uF【2.5】	0.1uF~0.47uF【1.25】 0.56uF~10uF【1.6】 12uF~100uF【2.5】
	16V	0.22~470【1.25】 560~22,000【1.6】	2,2uF~10uF【1.6】 15uF~22uF【2.5】	4.7uF~10uF【1.6】 12uF~100uF【2.5】	0.1uF~0.47uF【1.25】 0.56uF~10uF【1.6】 12uF~47uF【2.5】
	25V	0.22~470【1.25】 560~22,000【1.6】	2,2uF~10uF【1.6】 15uF~22uF【2.5】	4.7~10【1.6】 12~47【2.5】	0.1~0.47【1.25】 0.56~22【1.6】
	50V	0.22~470【1.25】 560~10,000【1.6】	1~10【1.6】	4.7~10【1.6】	—
1808	6.3V	0.22nF~4,700nF【1.6】	—	4.7uF~100uF【1.6】	—
	10V	0.22nF~4,700nF【1.6】	—	4.7uF~47uF【1.6】	—
	16V	0.22nF~4,700nF【1.6】	—	4.7uF~22uF【1.6】	—
	25V	0.22nF~4,700nF【1.6】	—	4.7uF~10uF【1.6】	—
	50V	0.22nF~4,700nF【1.6】	—	—	—



尺寸规格 Size Code	额定电压 Rated Voltage	容量范围 Capacitance			
		X7R (PF)	X7S (uF)	X5R(uF)	X6S(uF)
1812	6.3V	—	—	10uF~100uF 【2.5】	—
	10V	—	—	10uF~47uF 【2.5】	—
	16V	0.47nF~1,000nF 【1.6】 1,200nF~6,800nF 【2.5】	—	4.7uF~22uF 【2.5】	—
	25V	0.47nF~1,000nF 【1.6】 1,200nF~4,700nF 【2.5】	—	4.7uF~10uF 【2.5】	—
	50V	0.47nF~1,000nF 【1.6】 1,200nF~4,700nF 【2.5】	—	—	—

备注：1、【】对应容量的通用厚度，单位：mm

2、可根据客户的特殊要求设计符合客户需求的产品

Note: 1、【】 General thickness corresponds to the capacity, unit: mm

2、We can design according to the customer requirements.



## 六、中高压电容器 HIGH VOLTAGE MLCC

中高压多层片状陶瓷电容器是在多层片状陶瓷电容器的工艺技术、设备基础上，通过采用特殊工艺制作的一种具有良好高压可靠性的产品，该产品适合于表面贴装，适合于多种直流高压线路，可以有效的改善电子线路的性能。

### ●应用范围

- ※模拟或数字调制解调器。
- ※日光灯启动辉器照明电路。
- ※直流变速器。
- ※局域网/广域网接口界面。
- ※倍压电器。
- ※背光源驱动电路。

**Middle & high voltage MLCC is a kind of special design 、special technology MLCC that bases on the technology of general MLCC. This kind of MLCC has stable high voltage reliability and suitable to SMT. Middle & high MLCC is widely applicable for many direct high voltage circuits in which it can improve the performance of the circuit.**

### ●APPLICATIONS

- ※Analog & Digital Modems
- ※Lighting Ballast Circuits
- ※DC-DC Converters
- ※LAN/WAN Interface
- ※Voltage Multipliers
- ※Back-lighting Inverters

### ●容量范围及其电压

备注：1、【】对应容量的通用厚度，单位：mm

2、可根据客户的特殊要求设计符合客户需求的产品

Note: 1、【】 General thickness corresponds to the capacity, unit: mm

2、We can design according to the customer requirements.

尺寸规格 Size Code	工作电压 Rated Voltage	容量范围 Capacitance		
		NPO(pF)	X7R (nF)	Y5V(uF)
0402	100V	0.1~100 【0.5】	0.15~4.7 【0.5】	——
0603	100V	0.1~1,000 【0.8】	0.150~100 【0.8】	2.2~100 【0.8】
	200V	0.1~470 【0.8】	0.15~10 【0.8】	——
	250V	0.1~470 【0.8】	0.15~10 【0.8】	——
0805	100V	0.1~3,300 【0.8】	0.150~56 【0.8】 68~220 【1.25】	10~100 【0.8】
	200V~250V	0.1~1,000 【0.8】 1,200~1,500 【1.25】	0.15~18 【0.8】 20~22 【1.25】	10~47 【0.8】
	500V~630V	0.1~330 【0.8】 470~560 【1.25】	0.150~5.6 【0.8】 6.8~10 【1.25】	——
	1000V	0.1~100 【1.25】	——	——



容量范围及其电压

单位/unit: pF

尺寸规格 Size Code	工作电压 Rated Voltage	容量范围 Capacitance		
		NPO(pF)	X7R (nF)	Y5V(nF)
1206	100V	0.1~3,300 【0.8】	0.150~56 【0.8】 68~330 【1.25】 470~1,000 【1.6】	15~470 【0.8】
	200V~250V	0.1~1,800 【0.8】 2,000~2,700 【1.25】	0.150~27 【0.8】 33~150 【1.25】 180~220 【1.6】	10~220 【0.8】
	500V~630V	0.1~10 【0.8】 11~470 【1】 560~1,500 【1.25】	0.150~2.7 【0.8】 3.3~33 【1.25】	—
	1000V	0.1~120 【1】 150~1,000 【1.25】	0.150~1 【0.8】 1.1~12 【1.25】	—
	2000V	0.1~39 【1】 47~68 【1.25】 82~270 【1.6】	0.150~2.7 【1.25】	—
1210	100V	1.0~6,800 【1.25】	0.15~220 【1.25】 330~2,200 【1.6】	15~1,000 【1.25】
	200V~250V	1.0~3,300 【1.25】	0.150~150 【1.25】 180~220 【1.25】	15~470 【1.25】
	500V~630V	1.0~1,200 【1.25】 1,500~2,200 【1.6】	0.150~56 【1.25】 68~100 【1.6】	—
	1000V	1.0~680 【1.25】 820~1,200 【1.6】	0.150~3.9 【1.25】 4.7~22 【1.6】	—
	2000V	1.0~270 【1.25】 300~470 【1.6】	0.150~2.7 【1.25】 3.3~10 【1.6】	—
	3000V	—	150~680 【1.25】	—
	4000V	—	150~680 【1.25】	—



容量范围及其电压

单位/unit: pF

尺寸规格 Size Code	工作电压 Rated Voltage	容量范围 Capacitance		
		NPO(pF)	X7R (nF)	Y5V(nF)
1808	100V	2.0~4,700 【1.6】	0.220~2,200 【1.6】	150~1,000 【1.25】
	200V~250V	2.0~3,900 【1.6】	0.22~220 【1.6】	10~390 【1.25】
	500V~630V	2.0~2,700 【1.6】	0.220~68 【1.6】	—
	1000V	2.0~1,000 【1.6】	0.15~22 【1.6】	—
	2000V	2.0~470 【1.6】	0.15~10 【1.6】	—
	3000V	2.0~330 【1.6】	0.15~4.7 【1.6】	—
	4000V	2.0~33 【1.6】	0.15~2.2 【1.6】	—
	5000V	2.0~33 【1.6】	—	—
1812	100V	3.0~10,000 【1.25】	0.27~560 【1.6】 680~1,000 【2】	150~2,200 【1.6】
	200V~250V	3.0~6,800 【1.25】	0.27~220 【1.6】 330~560 【2】	100~470 【1.6】
	500V~630V	3.0~1,000 【1.25】 1,200~4,700 【1.6】	0.27~100 【1.6】 120~220 【2】	—
	1000V	3.0~1,200 【1.6】	0.27~47 【1.6】 56 【2】	—
	2000V	3.0~1,000 【1.6】	0.27~12 【1.6】	—
	3000V	3.0~560 【1.6】	0.27~4.7 【1.6】	—
	4000V	3.0~220 【1.6】	0.27~3.3 【1.6】	—
	5000V	3.0~68 【1.6】	—	—
1825	100V	3.0~22,000 【1.6】	12~2,200 【1.6】	150~2,200 【1.6】
	200V-250	3.0~8,200 【1.6】	12~100 【1.6】 120~1,200 【2.5】	100~470 【1.6】
	500V-630	3.0~5,600 【1.6】	1~470 【1.6】	—
	1000V	3.0~1,800 【1.6】	1~100 【1.6】	—
	2000V	3.0~1,000 【1.6】	1~22 【1.6】	—
	3000V	3.0~680 【1.6】	1~10 【1.6】	—
	4000V	3.0~470 【1.6】	1~6.8 【1.6】	—
	5000V	3.0~82 【1.6】	—	—





尺寸规格 Size Code	工作电压 Rated Voltage	容量范围 Capacitance		
		NPO(pF)	X7R (nF)	Y5V(nF)
2220	100V	5.0~27,000 【1.6】	22~2,200 【1.6】	150~1,500 【1.6】
	200V~250V	5.0~12,000 【1.6】	22~1,200 【1.6】	100~1,000 【1.6】
	500V~630V	5.0~6,800 【1.6】	1.5~470 【1.6】	——
	1000V	5.0~3,900 【1.6】	1.5~33 【1.6】 39~150 【2】	——
	2000V	5.0~1,000 【1.6】	1.5~6.8 【1.6】 22~47 【2】	——
	3000V	5.0~680 【1.6】	1.5~12 【2】	——
	4000V	5.0~560 【1.6】	1.5~8.2 【2】	——
	5000V	5.0~120 【1.6】	——	——
2225	100V	5.0~27,000 【1.6】	2.2~1,500 【1.6】 2,200 【2】	250~3,300 【1.6】
	200V~250V	5.0~12,000 【1.6】	2.2~680 【1.6】 1,000~2,200 【2】	220~2,200 【1.6】
	500V~630V	5.0~6,800 【1.6】	2.2~470 【1.6】	——
	1000V	5.0~3,900 【1.6】	2.2~100 【1.6】	——
	2000V	5.0~1,000 【1.6】	2.2~47 【1.6】	——
	3000V	5.0~680 【1.6】	2.2~15 【1.6】	——
	4000V	5.0~560 【1.6】	2.2~6.8 【1.6】	——
	5000V	5.0~120 【1.6】	——	——

备注：1、【】对应容量的通用厚度，单位：mm

2、可根据客户的特殊要求设计符合客户需求的产品

Note: 1、【】 General thickness corresponds to the capacity, unit: mm

2、We can design according to the customer requirements.



中高压电容器介质耐电强度的测试方法:

Measurement method of dielectric withstanding voltage for high voltage MLCC

额定电压范围 Rated voltage range	耐电性能的测试方法 Measuring Method
$100V \leq V_r < 500V$	施加额定电压的 200%, 5 秒, 最大电流不超过 50mA Force 200% Rated voltage for 5 second. Max. current should not exceed 50 mA.
$500V \leq V_r \leq 1000V$	施加额定电压的 150%, 5 秒, 最大电流不超过 50mA Force 150% Rated voltage for 5 second. Max. current should not exceed 50 mA.
$1000V < V_r \leq 2000V$	施加额定电压的 120%, 5 秒, 最大电流不超过 50mA Force 120% Rated voltage for 5 seconds. Max. current should not exceed 50 mA.
$2000V < V_r \leq 5000V$	施加额定电压的 120%, 5 秒, 最大电流不超过 10mA Force 120% Rated voltage for 5 seconds. Max. current should not exceed 10 mA.

七、可靠性测试 Reliability Test

项目 Item	技术规格 Technical Specification		测试方法 Test Method and Remarks			
			标称容量 Capacitance	测试频率 Measuring Frequency	测试电压 Measuring Voltage	
容量 Capacitance	I类 Class I	应符合指定的误差级别 Should be within the specified tolerance.	$\leq 1000\text{pF}$	$1\text{MHz} \pm 10\%$	$1.0 \pm 0.2\text{Vrms}$	
			$> 1000\text{pF}$	$1\text{KHz} \pm 10\%$		
容量 Capacitance	II类 Class II	应符合指定的误差级别 Should be within the specified tolerance.	测试温度: $25^\circ\text{C} \pm 3^\circ\text{C}$ Test Temperature: $25^\circ\text{C} \pm 3^\circ\text{C}$			
			$C \leq 10\mu\text{F}$ : 测试频率: $1\text{KHz} \pm 10\%$ 测试电压: $1.0 \pm 0.2\text{Vrms}$ Test Frequency: $1\text{KHz} \pm 10\%$ Test Voltage: $1.0 \pm 0.2\text{Vrms}$ $C > 10\mu\text{F}$ X7R、X5R、X7S、X6S、Y5V: 测试频率: $120 \pm 24\text{Hz}$ 测试电压: $0.5 \pm 0.1\text{Vrms}$ Test Frequency: $120 \pm 24\text{Hz}$ Test Voltage: $0.5 \pm 0.1\text{Vrms}$ Z5U: 测试频率: $1 \pm 0.1\text{KHz}$ 测试电压: $0.5 \pm 0.05\text{Vrms}$ Test Frequency: $1 \pm 0.1\text{KHz}$ Test Voltage: $0.5 \pm 0.05\text{Vrms}$			
损耗角正切 (DF, $\tan \delta$ ) Dissipation Factor	I类 Class I	DF	标称容量 Capacitance	测试频率 Measuring Frequency	测试电压 Measuring Voltage	
			$\leq 0.56\%$	$\text{Cr} < 5\text{pF}$	$1\text{MHz} \pm 10\%$	$1.0 \pm 0.2\text{Vrms}$
			$1.5[(150/\text{Cr})+7] \times 10^{-4}$	$5\text{pF} \leq \text{Cr} < 50\text{pF}$	$1\text{MHz} \pm 10\%$	
			$\leq 0.15\%$	$50\text{pF} \leq \text{Cr} \leq 1000\text{pF}$	$1\text{MHz} \pm 10\%$	
$\leq 0.15\%$	$> 1000\text{pF}$	$1\text{KHz} \pm 10\%$				



项目 Item	技术规格 Technical Specification							测试方法 Test Method and Remarks	
*损耗角正切(DF, tan δ) Dissipation Factor	II类 Class II	电压	DF	0201	0402	0603	0805	1206及以上	$C \leq 10\mu F$ 测试频率: 1KHz $\pm$ 10% 测试电压: 1.0 $\pm$ 0.2Vrms Test Frequency: 1KHz $\pm$ 10% Test Voltage: 1.0 $\pm$ 0.2Vrms  $C > 10\mu F$ X7R、X5R、X7S、X6S、Y5V 测试频率: 120 $\pm$ 24 Hz 测试电压: 0.5 $\pm$ 0.1Vrms Test Frequency: 120 $\pm$ 24Hz Test Voltage: 0.5 $\pm$ 0.1Vrms Z5U: 测试频率: 1 $\pm$ 0.1KHz 测试电压: 0.5 $\pm$ 0.05Vrms Test Frequency: 1 $\pm$ 0.1KHz Test Voltage: 0.5 $\pm$ 0.05Vrms
		50V	$\leq 2.5\%$	$\leq 3.3nF$	$\leq 22nF$	$\leq 100nF$	$\leq 1\mu F$	$\leq 1\mu F$	
			$\leq 3.5\%$	$\leq 10nF$	$\leq 100nF$	$\leq 470nF$	---	$\leq 4.7\mu F$	
			$\leq 10\%$	---	$\leq 1\mu F$	$\leq 2.2\mu F$	$\leq 4.7\mu F$	$\leq 10\mu F$	
		25V	$\leq 2.5\%$	$\leq 3.3nF$	$\leq 22nF$	$\leq 330nF$	$\leq 1\mu F$	$\leq 3.3\mu F$	
			$\leq 3.5\%$	$\leq 10nF$	$\leq 100nF$	$\leq 1\mu F$	$\leq 2.2\mu F$	$\leq 4.7\mu F$	
			$\leq 7.5\%$	---	---	---	$\leq 4.7\mu F$	$\leq 10\mu F$	
		16V	$\leq 10\%$	$\leq 100nF$	$\leq 2.2\mu F$	$\leq 10\mu F$	$\leq 22\mu F$	$\leq 22\mu F$	
			$\leq 2.5\%$	$\leq 3.3nF$	$\leq 47nF$	$\leq 330nF$	$\leq 470nF$	$\leq 3.3\mu F$	
			$\leq 3.5\%$	$\leq 15nF$	$\leq 220nF$	$\leq 1\mu F$	$\leq 2.2\mu F$	$\leq 4.7\mu F$	
		10V	$\leq 5\%$	$\leq 47nF$	---	---	$\leq 4.7\mu F$	---	
			$\leq 7.5\%$	---	---	---	$\leq 10\mu F$	---	
			$\leq 10\%$	$\leq 100nF$	$\leq 2.2\mu F$	$\leq 10\mu F$	$\leq 22\mu F$	$\leq 22\mu F$	
			$\leq 10\%$	$\leq 1\mu F$	$\leq 4.7\mu F$	$\leq 22\mu F$	$\leq 22\mu F$	$\leq 47\mu F$	
		$\leq 6.3V$	$\leq 2.5\%$	$\leq 3.3nF$	---	---	---	$\leq 3.3\mu F$	
			$\leq 3.5\%$	$\leq 15nF$	$\leq 220nF$	$\leq 470nF$	---	$\leq 4.7\mu F$	
			$\leq 5\%$	$\leq 47nF$	$\leq 1\mu F$	$\leq 2.2\mu F$	---	---	
			$\leq 7.5\%$	---	---	---	10 $\mu F$ ~22 $\mu F$	$\leq 47\mu F$	
		V	$\leq 10\%$	$\leq 22\mu F$	$\leq 10\mu F$	$\leq 22\mu F$	$\leq 47\mu F$	$\leq 107$	
		绝缘电阻 (IR) Insulation Resistance	I类 Class I	$C \leq 10 nF, Ri \geq 50000M \Omega$ $C > 10 nF, Ri \cdot C_R \geq 500S$					
II类 Class II	X7R/ X5R/ X7S/ X6S		$C \leq 25 nF, Ri \geq 10000M \Omega$ $C > 25 nF, Ri \cdot C_R > 100S$						
	Y5V Z5U		$C \leq 25 nF, Ri \geq 4000M \Omega$ $C > 25 nF, Ri \cdot C_R > 100S$						

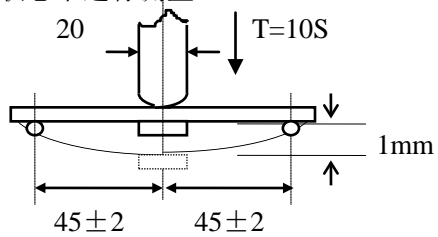

项目 Item	技术规格 Technical Specification				测试方法 Test Method and Remarks
介质耐电强度 (DWV) Dielectric Withstanding Voltage	不应有介质被击穿或损伤 No breakdown or damage.				测量电压: I类: 300%额定电压 II类: 250%额定电压 时间: 1~5秒 充/放电电流: 不应超过 50mA (这部分说明不包括中高压 MLCC) Measuring Voltage: <b>Class I</b> :300% Rated voltage <b>Class II</b> :250% Rated voltage <b>Duration</b> : 1~5s <b>Charge/ Discharge Current</b> : 50mA max. (This method excludes high-voltage MLCC)
可焊性 Solderability	上锡率应大于 95% 外观: 无可见损伤. At least 95% of the terminal electrode is covered by new solder. Visual Appearance: No visible damage.				将电容在 80~120℃的温度下预热 10~30秒. Preheating conditions:80 to 120℃; 10~30s. 有铅焊料: (Sn/Pb: 63/37) 无铅焊料: 浸锡温度: 235±5℃ 浸锡温度: 245±5℃ 浸锡时间: 2±0.5s 浸锡时间: 2±0.5s Solder Temperature: 235±5℃ Solder Temperature: 245±5℃ Duration: 2±0.5s Duration: 2±0.5s
耐焊接热 Resistance to Soldering Heat	项目 Item	NPO 至 SL NPO to SL	X7R/X5R/ X7S/X6S	Y5V、 Z5U	将电容在 100~200℃的温度下预热 10±2 分钟. 浸锡温度: 265±5℃ 浸锡时间: 10±1s 然后取出溶剂清洗干净, 在 10 倍以上的显微镜底下观察. 放置时间: 24±2 小时 放置条件: 室温 Preheating conditions: 100 to 200℃; 10±2min. Solder Temperature: 265±5℃ Duration: 10±1s Clean the capacitor with solvent and examine it with a 10X(min.) microscope. Recovery Time: 24±2h Recovery condition: Room temperature
	ΔCC	≤ ± 0.5% 或 ± 0.5PF, 取较大值 ≤ ± 0.5% or ± 0.5PF, whichever is larger	-5~+10%	-10~+2 0%	
	DF	同初始标准 Same to initial value.			
	IR	同初始标准 Same to initial value.			
	外观: 无可见损伤 上锡率: ≥95% Appearance: No visible damage. At least 95% of the terminal electrode is covered by new solder.				
*抗弯曲强度 Resistance to Flexure of Substrate (Bending Strength)	外观: 无可见损伤. Appearance: No visible damage.				试验基板: Al <sub>2</sub> O <sub>3</sub> 或 PCB 弯曲深度: 1mm 施压速度: 1mm/sec. 单位: mm 应在弯曲状态下进行测量.  Test Board: Al <sub>2</sub> O <sub>3</sub> or PCB Warp: 1mm Speed: 1mm/sec. Unit: mm The measurement should be made with the board in the bending position.
ΔC/C	≤ ± 10%				



项目 Item	技术规格 Technical Specification	测试方法 Test Method and Remarks																														
端头结合强度 Termination Adhesion	外观无可见损伤 No visible damage.	施加的力: 5N      时间: 10±1S Applied Force: 5N      Duration: 10±1S																														
温度循环 Temperature Cycle	<p>Δ C/C: I类: ≤±1%或±1pF, 取两者中最大者 II类: B,X,BS,DS: ≤±10% E,F: ≤±20%</p> <p>Class I: ≤±1% or ±1pF, whichever is larger. Class II: B,X,BS,DS: ≤±10% E,F: ≤±20%</p>	<p>预处理* (2类): 上限类别温度, 1小时 恢复: 24±1h 初始测量 循环次数: 5次, 一个循环分以下4步:</p> <table border="1"> <thead> <tr> <th>阶段</th> <th>温度 (°C)</th> <th>时间 (分钟)</th> </tr> </thead> <tbody> <tr> <td>第1步</td> <td>下限温度 (<math>\begin{smallmatrix} \text{NPO/X7R/X7S/X6S/X5R-55} \\ \text{Y5V-25 Z5U-10} \end{smallmatrix}</math>)</td> <td>30</td> </tr> <tr> <td>第2步</td> <td>常温 (+20)</td> <td>2~3</td> </tr> <tr> <td>第3步</td> <td>上限温度 (<math>\begin{smallmatrix} \text{NPO/X7R/X7S-+125} \\ \text{Y5V/Z5U/X5R-+85 X6S-+105} \end{smallmatrix}</math>)</td> <td>30</td> </tr> <tr> <td>第4步</td> <td>常温 (+20)</td> <td>2~3</td> </tr> </tbody> </table> <p>试验后放置 (恢复) 时间: 24±2h Preheating conditions: up-category temperature, 1h Recovery time: 24±1h Initial Measurement Cycling Times: 5 times, 1 cycle, 4 steps:</p> <table border="1"> <thead> <tr> <th>Step</th> <th>Temperature (°C)</th> <th>Time (min.)</th> </tr> </thead> <tbody> <tr> <td>1</td> <td>Low-category temp. (<math>\begin{smallmatrix} \text{NPO/X7R/X7S/X6S/X5R-55} \\ \text{Y5V-25 Z5U-10} \end{smallmatrix}</math>)</td> <td>30</td> </tr> <tr> <td>2</td> <td>Normal temp. (+20)</td> <td>2~3</td> </tr> <tr> <td>3</td> <td>Up-category temp. (<math>\begin{smallmatrix} \text{NPO/X7R/X7S-+125} \\ \text{Y5V/Z5U/X5R-+85 X6S-+105} \end{smallmatrix}</math>)</td> <td>30</td> </tr> <tr> <td>4</td> <td>Normal temp. (+20)</td> <td>2~3</td> </tr> </tbody> </table> <p>Recovery time after test: 24±2h</p>	阶段	温度 (°C)	时间 (分钟)	第1步	下限温度 ( $\begin{smallmatrix} \text{NPO/X7R/X7S/X6S/X5R-55} \\ \text{Y5V-25 Z5U-10} \end{smallmatrix}$ )	30	第2步	常温 (+20)	2~3	第3步	上限温度 ( $\begin{smallmatrix} \text{NPO/X7R/X7S-+125} \\ \text{Y5V/Z5U/X5R-+85 X6S-+105} \end{smallmatrix}$ )	30	第4步	常温 (+20)	2~3	Step	Temperature (°C)	Time (min.)	1	Low-category temp. ( $\begin{smallmatrix} \text{NPO/X7R/X7S/X6S/X5R-55} \\ \text{Y5V-25 Z5U-10} \end{smallmatrix}$ )	30	2	Normal temp. (+20)	2~3	3	Up-category temp. ( $\begin{smallmatrix} \text{NPO/X7R/X7S-+125} \\ \text{Y5V/Z5U/X5R-+85 X6S-+105} \end{smallmatrix}$ )	30	4	Normal temp. (+20)	2~3
阶段	温度 (°C)	时间 (分钟)																														
第1步	下限温度 ( $\begin{smallmatrix} \text{NPO/X7R/X7S/X6S/X5R-55} \\ \text{Y5V-25 Z5U-10} \end{smallmatrix}$ )	30																														
第2步	常温 (+20)	2~3																														
第3步	上限温度 ( $\begin{smallmatrix} \text{NPO/X7R/X7S-+125} \\ \text{Y5V/Z5U/X5R-+85 X6S-+105} \end{smallmatrix}$ )	30																														
第4步	常温 (+20)	2~3																														
Step	Temperature (°C)	Time (min.)																														
1	Low-category temp. ( $\begin{smallmatrix} \text{NPO/X7R/X7S/X6S/X5R-55} \\ \text{Y5V-25 Z5U-10} \end{smallmatrix}$ )	30																														
2	Normal temp. (+20)	2~3																														
3	Up-category temp. ( $\begin{smallmatrix} \text{NPO/X7R/X7S-+125} \\ \text{Y5V/Z5U/X5R-+85 X6S-+105} \end{smallmatrix}$ )	30																														
4	Normal temp. (+20)	2~3																														
*耐湿负荷 Humidity load	<table border="1"> <tr> <td>Δ C/C</td> <td>I类: ±7.5%或±0.75pF,取两者之中较大者 II类: B,X,BS,DS: ≤±12.5% E,F: ≤±30% Class I: ±7.5% or ±0.75pF, whichever is larger. Class II: B,X,BS,DS: ≤±12.5% E,F: ≤±30%</td> </tr> <tr> <td>DF</td> <td>≤2倍初始标准 Not more than twice of initial value.</td> </tr> <tr> <td rowspan="2">IR</td> <td>Class I Ri ≥ 5000MΩ 或 Ri • Cr ≥ 50S 取两者之中较小者. Ri ≥ 5000MΩ 或 Ri • Cr ≥ 50S whichever is smaller.</td> </tr> <tr> <td>Class II B, X, BS, DS Ri ≥ 1000MΩ 或 Ri • Cr ≥ 10S 取两者之中较小者. Ri ≥ 1000MΩ 或 Ri • Cr ≥ 10S whichever is smaller. E, F Ri ≥ 400MΩ 或 Ri • Cr ≥ 10S 取两者之中较小者. Ri ≥ 400MΩ 或 Ri • Cr ≥ 10S whichever is smaller.</td> </tr> <tr> <td colspan="2">外观: 无损伤 Appearance: No visible damage.</td> </tr> </table>	Δ C/C	I类: ±7.5%或±0.75pF,取两者之中较大者 II类: B,X,BS,DS: ≤±12.5% E,F: ≤±30% Class I: ±7.5% or ±0.75pF, whichever is larger. Class II: B,X,BS,DS: ≤±12.5% E,F: ≤±30%	DF	≤2倍初始标准 Not more than twice of initial value.	IR	Class I Ri ≥ 5000MΩ 或 Ri • Cr ≥ 50S 取两者之中较小者. Ri ≥ 5000MΩ 或 Ri • Cr ≥ 50S whichever is smaller.	Class II B, X, BS, DS Ri ≥ 1000MΩ 或 Ri • Cr ≥ 10S 取两者之中较小者. Ri ≥ 1000MΩ 或 Ri • Cr ≥ 10S whichever is smaller. E, F Ri ≥ 400MΩ 或 Ri • Cr ≥ 10S 取两者之中较小者. Ri ≥ 400MΩ 或 Ri • Cr ≥ 10S whichever is smaller.	外观: 无损伤 Appearance: No visible damage.		<p>温度: 40±2°C 湿度: 90~95%RH 电压: 额定电压 时间: 500小时 放置条件: 室温 放置时间: 24小时(I类); 48小时(II类)</p> <p>Temperature: 40±2°C Humidity: 90~95%RH Voltage: Rated Voltage Duration: 500h Recovery conditions: Room temperature Recovery Time: 24h (Class1) or 48h (Class2)</p>																					
Δ C/C	I类: ±7.5%或±0.75pF,取两者之中较大者 II类: B,X,BS,DS: ≤±12.5% E,F: ≤±30% Class I: ±7.5% or ±0.75pF, whichever is larger. Class II: B,X,BS,DS: ≤±12.5% E,F: ≤±30%																															
DF	≤2倍初始标准 Not more than twice of initial value.																															
IR	Class I Ri ≥ 5000MΩ 或 Ri • Cr ≥ 50S 取两者之中较小者. Ri ≥ 5000MΩ 或 Ri • Cr ≥ 50S whichever is smaller.																															
	Class II B, X, BS, DS Ri ≥ 1000MΩ 或 Ri • Cr ≥ 10S 取两者之中较小者. Ri ≥ 1000MΩ 或 Ri • Cr ≥ 10S whichever is smaller. E, F Ri ≥ 400MΩ 或 Ri • Cr ≥ 10S 取两者之中较小者. Ri ≥ 400MΩ 或 Ri • Cr ≥ 10S whichever is smaller.																															
外观: 无损伤 Appearance: No visible damage.																																



项目 Item	技术规格 Technical Specification		测试方法 Test Method and Remarks
*寿命试验 Life Test	Δ C/C	I 类: $\leq \pm 2\%$ 或 $\pm 1\text{pF}$ 取两者之中较大者 II 类: B,X,BS,DS: $\leq \pm 20\%$ E,F: $\leq \pm 30\%$ Class I : $\leq \pm 2\%$ or $\pm 1\text{pF}$ , whichever is larger. Class II : B,X,BS,DS: $\leq \pm 20\%$ E,F: $\leq \pm 30\%$	低压产品 ( $< 100\text{V}$ ) 电压: 2 倍额定工作电压 时间: 1000 小时 温度: $125^\circ\text{C}$ (NPO、X7R、X7S) $85^\circ\text{C}$ (X5R、Y5V) $105^\circ\text{C}$ (X6S) 充电电流: 不应超过 50mA 放置条件: 室温 放置时间: 24 小时 (I类), 或 48 小时 (II类), Low-Voltage ( $< 100\text{V}$ ) Applied Voltage: $2 \times \text{Rated Voltage}$ Duration: 1000h Temperature: $125^\circ\text{C}$ (NPO、X7R、X7S) $85^\circ\text{C}$ (X5R、Y5V) $105^\circ\text{C}$ (X6S) Charge/ Discharge Current: 50mA max. Recovery Conditions: Room Temperature Recovery Time: 24h (Class 1), or 48h (Class2)
		DF	
	IR	I 类: $R_i \geq 4000\text{M}\Omega$ 或 $R_i \cdot C_R \geq 40\text{S}$ 取两者之中较小者. Class I : $R_i \geq 4000\text{M}\Omega$ 或 $R_i \cdot C_R \geq 40\text{S}$ whichever is smaller.	
		II 类: $R_i \geq 2000\text{M}\Omega$ 或 $R_i \cdot C_R \geq 50\text{S}$ 取两者之中较小者. Class II : $R_i \geq 2000\text{M}\Omega$ 或 $R_i \cdot C_R \geq 50\text{S}$ whichever is smaller.	
外观: 无损伤 Visual Appearance: No visible damage.			
*中高压产品 寿命试验 Middle & high voltage Life Test	Δ C/C	I 类: $\leq \pm 2\%$ 或 $\pm 1\text{pF}$ 取两者之中较大者 II 类: B,X,BS,DS: $\leq \pm 20\%$ E,F: $\leq \pm 30\%$ Class I : $\leq \pm 2\%$ or $\pm 1\text{pF}$ , whichever is larger. Class II : B,X,BS,DS: $\leq \pm 20\%$ E,F: $\leq \pm 30\%$	中高压产品: $100\text{V} \leq \text{额定电压} \leq 200\text{V}$ : 1.5 倍工作电压 $200\text{V} < \text{额定电压} \leq 500\text{V}$ : 1.3 倍工作电压 $500\text{V} < \text{额定电压}$ : 1.2 倍工作电压 时间: 1000 小时 充电电流: 不应超过 50mA 温度: $125^\circ\text{C}$ (NPO X7R、X7S); $85^\circ\text{C}$ (X5R、Y5V) $105^\circ\text{C}$ (X6S) 放置条件: 室温 放置时间: 24 小时 (I类), 或 48 小时 (II类), Applied Voltage: $100\text{V} \leq \text{Rated Voltage} \leq 200\text{V}$ : 1.5 Multiple $200\text{V} < \text{Rated Voltage} \leq 500\text{V}$ : 1.3 Multiple $500\text{V} < \text{Rated Voltage}$ : 1.2 Multiple Duration: 1000h Charge/ Discharge Current: 50mA max. Temperature: $125^\circ\text{C}$ (NPO X7R、X7S); $85^\circ\text{C}$ (X5R、Y5V) $105^\circ\text{C}$ (X6S) Recovery Conditions: Room Temperature Recovery Time: 24h (Class 1), or 48h (Class2)
		DF	
	IR	I 类: $R_i \geq 4000\text{M}\Omega$ 或 $R_i \cdot C_R \geq 40\text{S}$ 取两者之中较小者. Class I : $R_i \geq 4000\text{M}\Omega$ 或 $R_i \cdot C_R \geq 40\text{S}$ whichever is smaller.	
		II 类: $R_i \geq 2000\text{M}\Omega$ 或 $R_i \cdot C_R \geq 50\text{S}$ 取两者之中较小者. Class II : $R_i \geq 2000\text{M}\Omega$ 或 $R_i \cdot C_R \geq 50\text{S}$ whichever is smaller.	
外观: 无损伤 Visual Appearance: No visible damage.			

注解:

专门预处理\* (仅对 2 类电容器):

将电容器放在上限类别温度或按详细规范中可能规定的更高温度下经 1h 后, 接着在试验的标准大气条件下恢复  $24 \pm 1\text{h}$ 。

Note: Pretreatment (only for class2 capacitor)

Pretreatment (only for class2 capacitor) is a method to treat the capacitor before measurement. First, place the capacitor in the up-category temperature or other specified higher temperature environment for 1hour. Then recovery the capacitor at standard pressure conditions for  $24 \pm 1\text{hours}$ 。



## 八、包装 PACKAGE

### ●塑料压纹带卷盘结构 EMBOSSED PLASTIC TAPING



※仅适用于 1005 规格，压纹带尺寸如下：

The emboss plastic applies only to 1005 type, the dimensions as follows:



Unit: mm

W	P0	P1	E	F	D0	A0	B0	K0
4±0.05	2±0.04	1±0.02	0.9±0.05	1.8±0.02	0.8±0.04	0.24±0.02	0.45±0.02	0.24±0.02



● 纸带卷盘结构 PAPER TAPING

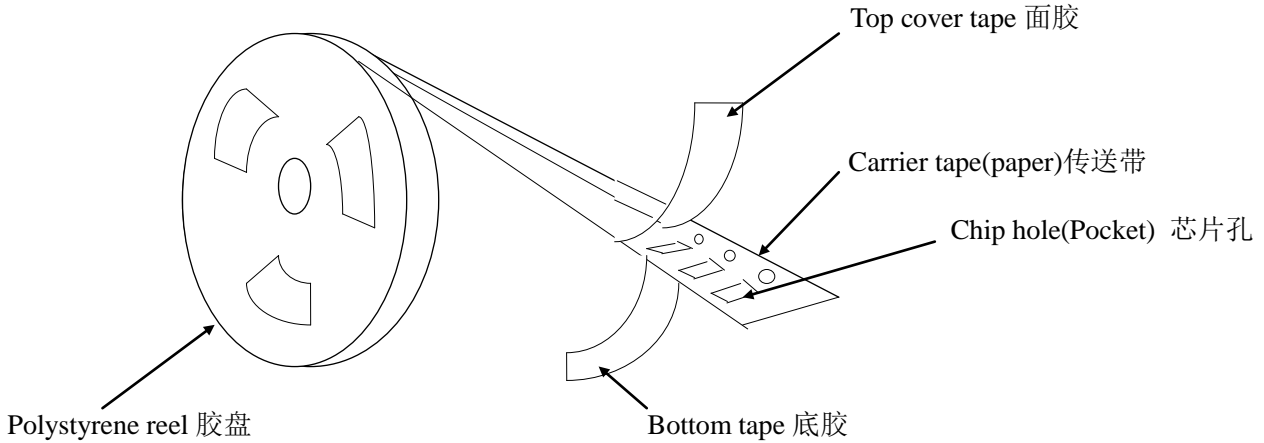

※ 1005、0201、0402 纸带编带尺寸大小

Dimensions of paper taping for 1005、0201、0402 type

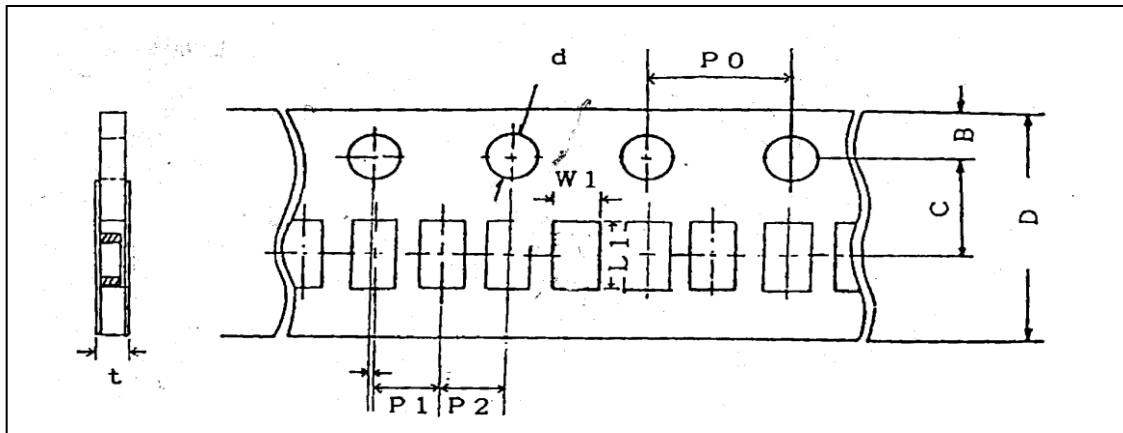

代号 Code	W1	L1	D	C	B	P1	P2	P0	d	t
1005	0.24± 0.02	0.45± 0.02	8.00± 0.10	3.50± 0.05	1.75± 0.10	2.00± 0.05	2.00± 0.05	4.00± 0.10	1.50 -0/+0.10	0.30 Below
0201	0.37± 0.10	0.67± 0.10	8.00± 0.10	3.50± 0.05	1.75± 0.10	2.00± 0.05	2.00± 0.05	4.00± 0.10	1.50 -0/+0.10	0.80 Below
0402	0.65± 0.10	1.15± 0.10	8.00± 0.10	3.50± 0.05	1.75± 0.10	2.00± 0.05	2.00± 0.05	4.00± 0.10	1.50 -0/+0.10	0.80 Below





※适合‘0603, 0805, 1206’常规尺寸产品的纸带尺寸  
Dimensions of paper taping for 0603, 0805, 1206 types.



Unit: mm

代号 Code 纸带规格 paper size	A	B	C	D*	E	F	G*	H	J	T
0603	1.10 ±0.10	1.90 ±0.10	800 ±0.10	350 ±0.05	1.75 ±0.10	400 ±0.10	200 ±0.10	400 ±0.10	150 -0/+0.10	1.10 Max
0805	1.45 ±0.15	2.30 ±0.15	800 ±0.15	350 ±0.05	1.75 ±0.10	400 ±0.10	200 ±0.10	400 ±0.10	150 -0/+0.10	1.10 Max
1206	1.80 ±0.20	3.40 ±0.20	800 ±0.20	350 ±0.05	1.75 ±0.10	400 ±0.10	200 ±0.10	400 ±0.10	150 -0/+0.10	1.10 Max

注意：\*表示此处对尺寸的要求非常精确。

Note: The place with “\*” means where needs exactly dimensions.

● 塑胶卷盘结构 EMBOSED TAPING





※ 塑胶带尺寸结构(适合‘0805~1812’型产品)

Dimensions of embossed taping for 0805~1812 type

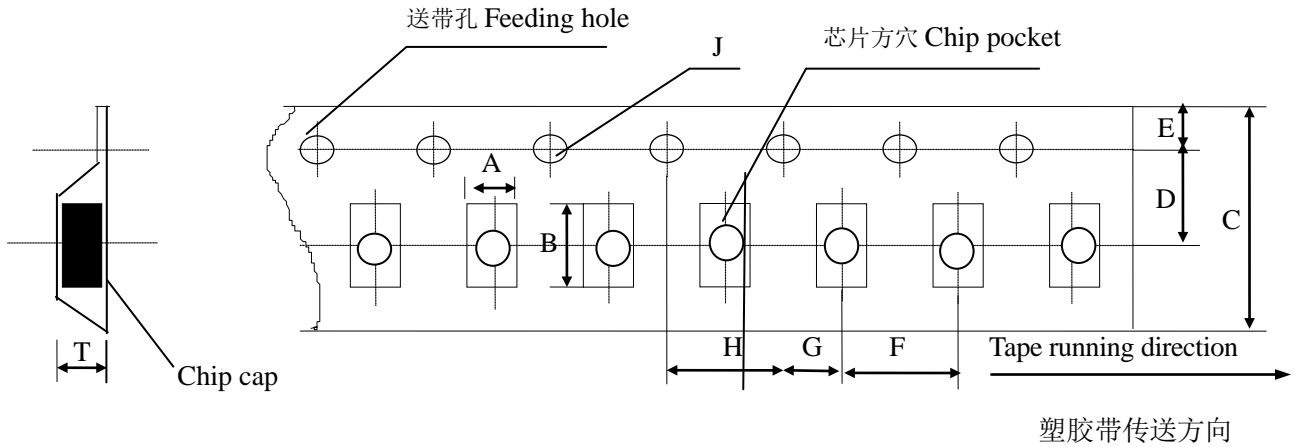

塑胶带传送方向

代号 Code 规格 Tape size	A	B	C	D*	E	F	G*	H	J	T
0805	1.55 ± 0.20	2.35 ± 0.20	8.00 ± 0.20	3.50 ± 0.05	1.75 ± 0.10	4.00 ± 0.10	2.00 ± 0.10	4.00 ± 0.10	1.50 -0/+0.10	1.50 Max
1206	1.95 ± 0.20	3.60 ± 0.20	8.00 ± 0.20	3.50 ± 0.05	1.75 ± 0.10	4.00 ± 0.10	2.00 ± 0.10	4.00 ± 0.1	1.50 -0/+0.10	1.85 Max
1210	2.70 ± 0.10	3.42 ± 0.10	8.00 ± 0.10	3.50 ± 0.05	1.75 ± 0.10	4.00 ± 0.10	2.00 ± 0.05	4.00 ± 0.10	1.55 -0/+0.10	3.2 Max
1808	2.20 ± 0.10	4.95 ± 0.10	12.00 ± 0.10	5.50 ± 0.05	1.75 ± 0.10	4.00 ± 0.10	2.00 ± 0.05	4.00 ± 0.10	1.50 -0/+0.10	3.0 Max
1812	3.66 ± 0.10	4.95 ± 0.10	12.00 ± 0.10	5.50 ± 0.05	1.75 ± 0.10	8.00 ± 0.10	2.00 ± 0.05	4.00 ± 0.10	1.55 -0/+0.10	4.0 Max

备注：\*表示此处对尺寸的要求非常精确。

Note: The place with “\*” means where needs exactly dimensions.

● 传送带的前后结构 Structure of leader part and end part of the carrier paper

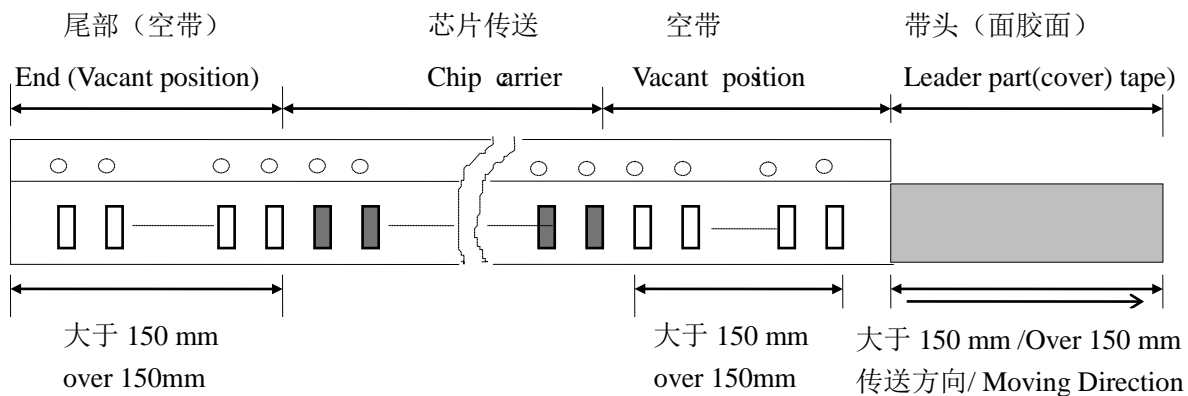



※ 卷盘尺寸 Reel Dimensions (unit: mm)

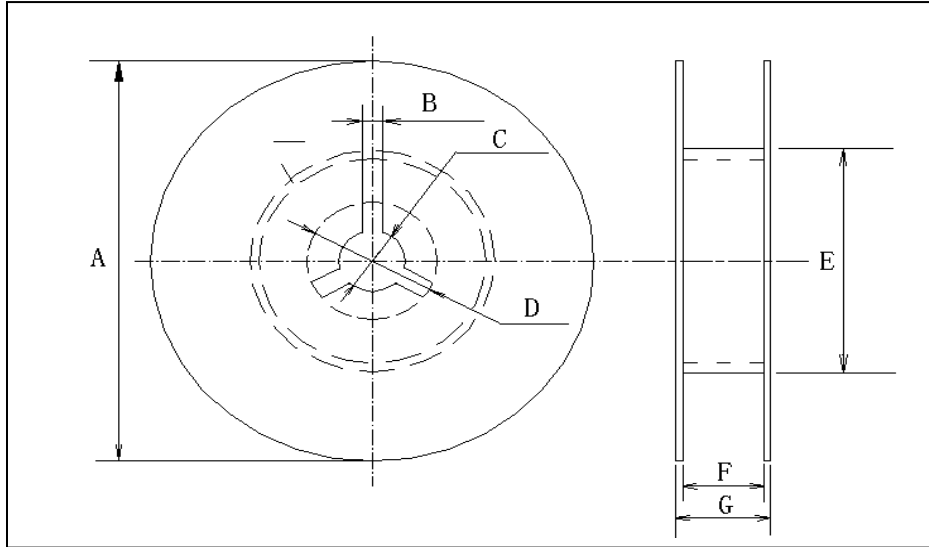

※ 尺寸代码 (CODE)

卷盘型号	A	B	C	D	E	F	G
7 REEL	$\phi 178 \pm 20$	3.0	$\phi 13 \pm 0.5$	$\phi 21 \pm 0.8$	$\phi 50$ 或更大 $\phi 50$ or more	$100 \pm 15$	12max
13' REEL	$\phi 330 \pm 20$	3.0	$\phi 13 \pm 0.5$	$\phi 21 \pm 0.8$	$\phi 50$ 或更大 $\phi 50$ or more	$100 \pm 15$	12max

● 关于卷带的说明 Taping specification

※ 面胶剥离强度 Top tape peeling strength

(a) 纸带 Paper Taping



(b) 塑料胶盘 Embossed Taping



标准:  $0.1N < \text{剥离强度} < 0.7N$

Standard:  $0.1N < \text{peeling strength} < 0.7N$

在剥离时, 纸带不能有纸碎, 也不能粘在底、面胶上。

No paper dirty remains on the scotch when peeling, and sticks to top and bottom tape.



※塑料盒散包装 Bulk Case Package

单位 (unit) :mm

Symbol	A	B	T	C	D	E
Dimension	6.80±0.10	8.80±1.00	12.00±0.10	15.00+0.10/-0	2.00+0/-0.10	4.70±0.10
Symbol	F	W	G	H	L	I
Dimension	31.50+0.20/-0	36.00+0/-0.20	19.00±0.35	7.00±0.35	110.00±0.70	5.00±0.35

※ 包装数量 Packing Quantity

尺寸 (SIZE)	包装形式和数量 (PACKAGE STYLE & QUANTITY) unit: pcs				
	塑料压纹带卷盘 (EPT)	纸带卷盘 (PT)	胶带卷盘 (ET)	塑料盒散装 (BC)	一般散装 (BP)
1005	40000	20000	-----	-----	-----
0201	-----	15000	-----	20000	5000
0402	-----	10000	-----	20000	5000
0603	-----	4000	-----	15000	5000
0805	-----	4000	3000	10000	5000
1206	-----	4000	T≤1.35mm 3000 T>1.35mm 2000	5000	5000
1210	-----	-----	T≤1.80mm 2000 T>1.80mm 1000	-----	2000
1808	-----	-----	2000	-----	2000
1812	-----	-----	T≤1.85mm 1000 T>1.85mm 500	-----	2000
1825、2220、 2025、2225	-----	-----	500	-----	500

注意：包装的形式和数量可根据客户的要求来定。

Note: We can choose packing style and quantity can be according to the customer's requirement.



### ●外包装 Outer packing

小包装 The first package

Quantity: 10 reels

数量: 10 卷

大包装 The second package

Quantity: 6 cases

数量: 6 盒

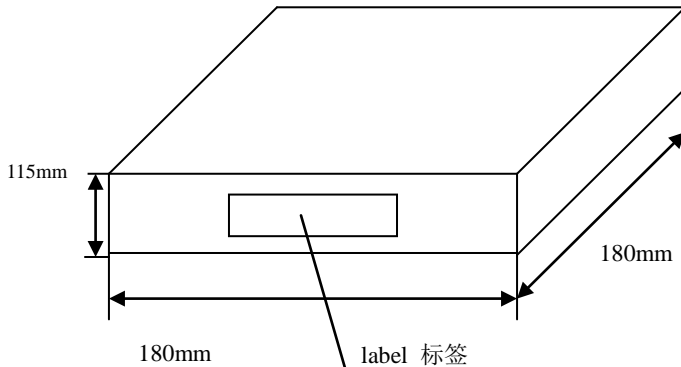

PART No 型号规格  
QUANTITY 数量  
DATE 日期

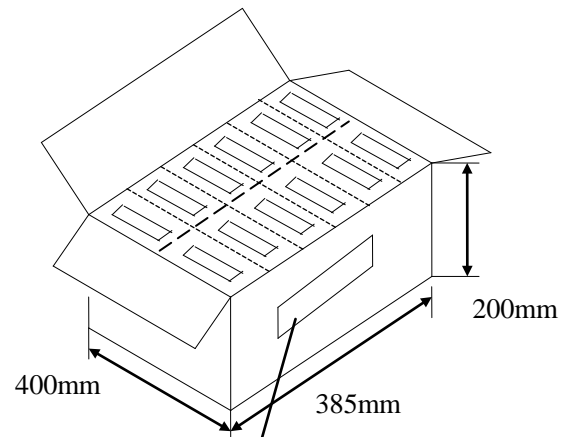

Production name 产品名称  
Quantity 数量  
Weight 重量

### \*九、储存方法 Storage Methods

确保芯片可焊性良好的贮存期限为 12 个月(在包装好已交付的情况下)。

The guaranteed period for solderability is 12 months (Under deliver package condition).

储存条件/Storage conditions:

储存温度/Temperature 5~40°C

储存相对湿度/Relative Humidity 20~70%

### 十、使用前的注意事项 Precautions For Use

多层片式瓷介电容器(MLCC)在短路或开路的电路中都有可能失效,在超出本承认书或相关说明书中所述使用频率的恶劣工作环境,或外界机械力超压作用下,电容芯片都有可能着火、燃烧甚至爆炸,所以在使用的時候,首先应考虑按本承认书的有关说明来进行,如有不明之处,请联系我们技术部、品管部或生产部。

The Multi-layer Ceramic Capacitors (MLCC) may fail in a short circuit modern in an open circuit mode when subjected to severe conditions of electrical environment and / or mechanical stress beyond the specified "rating" and specified "conditions" in the specification, which will result in burn out, flaming or glowing in the worst case. Following "precautions for "safety" and Application Notes shall be taken in your major consideration. If you have a question about the precautions for handling, please contact our engineering section or factory.

#### 1. 焊接的条件与相关图表 Soldering Profile

为避免因温度的突然变化而引起的芯片开裂或局部爆炸的现象发生,请按有关温度曲线图表来进行。(请参考附页中的图表)

To avoid the crack problem by sudden temperature change, follow the temperature profile in the adjacent graph (refer to the graph in the enclosure page).



## 2. 手工焊接 Manual Soldering

手工焊接很容易因为芯片局部受热不均而引起瓷体微裂或局部爆炸的现象,在焊接时,如果操作者不小心,会使烙铁头直接同电容芯片的瓷体部分接触,这样很容易使电容芯片因热冲击而受损或出现其他意外.因此,使用电烙铁手工焊接时应仔细操作,并对电烙铁的尖端的选择和尖端温度控制应多加小心.

Manual soldering can pose a great risk of creating thermal cracks in capacitors. The hot soldering iron tip comes into direct contact with the end terminations, and operator's careless may cause the tip of the soldering iron to come into direct contact with the ceramic body of the capacitor. Therefore the soldering iron must be handled carefully, and pay much attention to the selection of the soldering iron tip and temperature contact of the tip.

## 3. 适量的焊料 Optimum Solder Amount for Reflow Soldering

焊料过多  
Too much solder



这样会因端头压力过大而可能引起芯片受损  
Cracks tend to occur due to large stress.

焊料太少  
Not enough solder



固定力量不足,可能会引起电容芯片与线路接触不良  
Weak holding force may cause bad connection between the capacitor and PCB.

## 4. 推荐焊料用量 Recommended Soldering amounts

### 4.1 回流焊接的最佳焊料用量

The optimal solder fillet amounts for re-flow soldering



### 4.2 波峰焊接的最佳焊料用量

The optimal solder fillet amounts for wave soldering



### 4.3 使用烙铁返修时的最佳焊料量

The optimal solder fillet amounts for reworking by using soldering iron





十一、推荐焊接方式 Recommended Soldering Method

规格尺寸 Size	温度特性 Temperature Characteristics	额定电压 Rated Voltage	容量范围 Capacitance	焊接方式 Soldering Method
1005	NPO	/	/	R
	X7R/X5R/X7S/X6S	/	/	R
0201	NPO	/	/	R
	X7R/X5R/X7S/X6S	/	/	R
	Y5V	/	/	R
0402	NPO	/	/	R
	X7R/X5R/X7S/X6S	/	/	R
	Y5V	/	/	R
0603	NPO	/	/	R/W
	X7R/X5R/X7S/X6S	/	$C \geq 1\mu\text{f}$	R
			$C < 1\mu\text{f}$	R/W
	Y5V	/	$C \geq 1\mu\text{f}$	R
			$C < 1\mu\text{f}$	R/W
0805	NPO	/	/	R/W
	X7R/X5R/X7S/X6S	/	$C \geq 4.7\mu\text{f}$	R
			$C < 4.7\mu\text{f}$	R/W
	Y5V	/	$C \geq 1\mu\text{f}$	R
			$C < 1\mu\text{f}$	R/W
1206	NPO	/	/	R/W
	X7R/X5R/X7S/X6S	/	$C \geq 10\mu\text{f}$	R
			$C < 10\mu\text{f}$	R/W
	Y5V	/	$C \geq 10\mu\text{f}$	R
			$C < 10\mu\text{f}$	R/W
$\geq 1210$	NPO	/	/	R
	X7R/X5R/X7S/X6S	/	/	R
	Y5V	/	/	R

焊接方式 Soldering method: R—回流焊 Reflow Solering

W—波峰焊 Wave Soldering



## 十二、推荐焊接温度曲线图 The temperature profile for soldering

### 回流焊接 (Re-flow soldering)

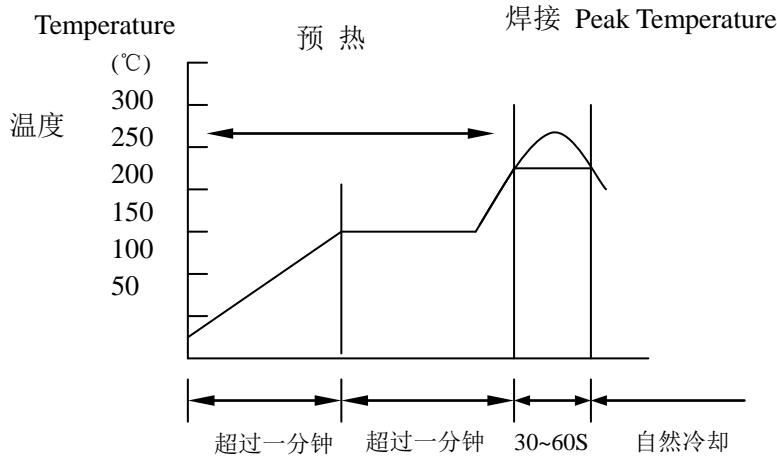

	Pb-Sn 焊接 Pb-Sn soldering	无铅焊接 Lead-free soldering
尖峰温度 Peak temperature	230°C~250°C	240°C~260°C

在预热时, 请将焊接温度与芯片表面温度之间的温差维持在  $T \leq 150^\circ\text{C}$ 。

While in preheating, please keep the temperature difference between soldering temperature and surface temperature of chips as:  $T \leq 150^\circ\text{C}$ .

### 波峰焊接 (Wave soldering)

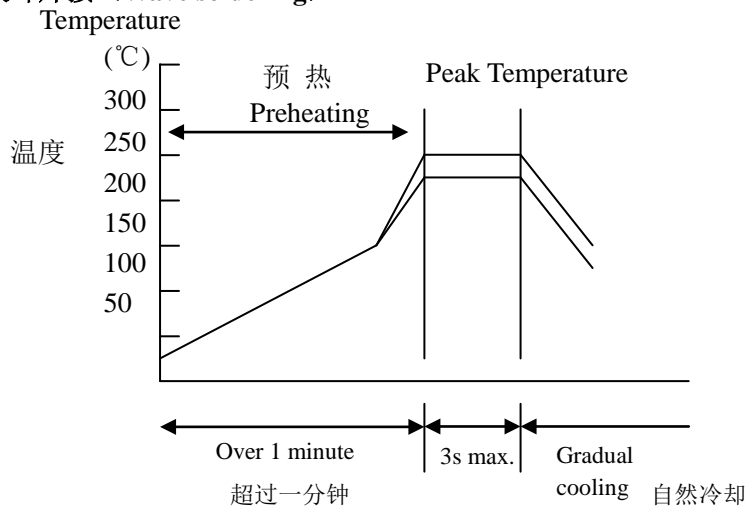

	Pb-Sn 焊接 Pb-Sn soldering	无铅焊接 Lead-free soldering
尖峰温度 Peak temperature	230°C~260°C	240°C~270°C

在预热时, 请将焊接温度与芯片表面温度之间的温差维持在  $T \leq 150^\circ\text{C}$ 。

While in preheating, please keep the temperature difference between soldering temperature and surface temperature of chips as:  $T \leq 150^\circ\text{C}$ .





手工焊接 (Hand soldering)

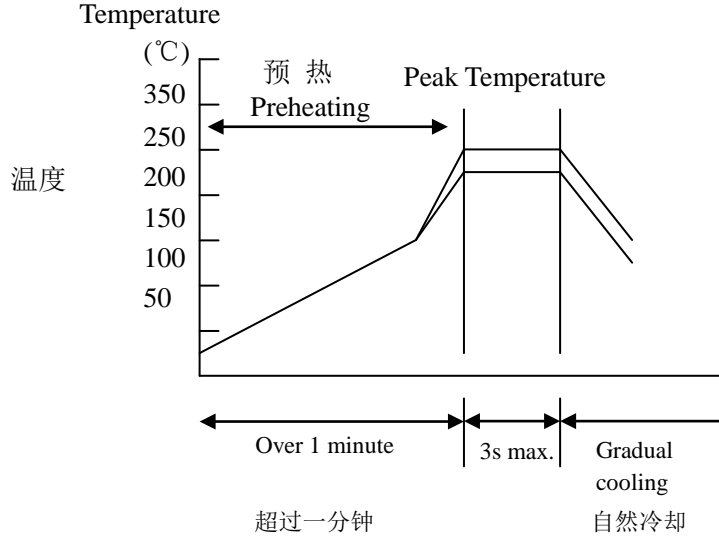

条件 Conditions:

预热 Preheating	烙铁头温度 Temperature of soldering iron head	烙铁功率 Power of soldering iron	烙铁头直径 Diameter of soldering iron head	焊接时间 Soldering time	锡膏量 Solder paste amount	限制条件 Restricted conditions
$\Delta \leq 130^{\circ}\text{C}$	最高350°C Highest temperature:350°C	最大20W 20W at the highest	建议1mm 1mm recommended	最长3s 3s at the longest	$\leq 1/2$ 芯片厚度 $\leq 1/2$ chip thickness	请勿使用烙铁头直接接触陶瓷元件 Please avoid the direct contact between soldering iron head and ceramic components

※以最新版本的内容为准

