

## Current Transducer LT 508-S6

For the electronic measurement of currents: DC, AC, pulsed..., with galvanic separation between the primary circuit and the secondary circuit.

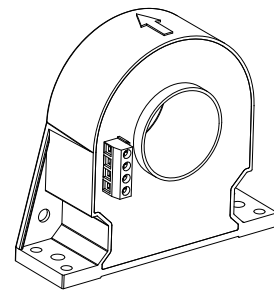

$$I_{PN} = 500 \text{ A}$$



### Electrical data

$I_{PN}$	Primary nominal rms current	500	A
$I_{PM}$	Primary current, measuring range	0 ... ±800	A
$R_M$	Measuring resistance with ±15 V	@ ±500 A <sub>max</sub>	$R_{M \min}$ 0 $R_{M \max}$ 40    Ω
		@ ±800 A <sub>max</sub>	0    5    Ω
	with ±18 V	@ ±500 A <sub>max</sub>	0    60    Ω
		@ ±800 A <sub>max</sub>	0    15    Ω
$I_{SN}$	Secondary nominal rms current	100	mA
$K_N$	Conversion ratio	1 : 5000	
$U_C$	Supply voltage (±5 %)	±15 ... 18	V
$I_C$	Current consumption	20 (@±15V) + $I_S$	mA

### Accuracy - Dynamic performance data

$X_G$	Overall accuracy @ $I_{PN}$ , $T_A = 25 \text{ °C}$	±0.4	%
$\epsilon_L$	Linearity error	< 0.1	%
$I_{OE}$	Electrical offset current @ $I_P = 0$ , $T_A = 25 \text{ °C}$	Typ	±0.13
		Max	±0.13
$I_{OM}$	Magnetic offset current <sup>1)</sup> @ $I_P = 0$ and specified $R_M$ , after an overload of $1 \times I_{PN}$	±0.14	mA
$I_{OT}$	Temperature variation of $I_O$ -10 °C ... +70 °C	±0.15	±0.64
$t_{ra}$	Reaction time	< 500	ns
$t_r$	Step of response time <sup>2)</sup> to 90 % of $I_{PN}$	< 1	µs
$di/dt$	$di/dt$ accurately followed	> 100	A/µs
$BW$	Frequency bandwidth (-3 dB)	DC ... 100	kHz

### General data

$T_A$	Ambient operating temperature	-10 ... +70	°C
$T_S$	Ambient storage temperature	-25 ... +80	°C
$R_S$	Resistance of secondary winding @ $T_A = 70 \text{ °C}$	60	Ω
$m$	Mass	320	g
	Standards	EN 50178: 1997 UL 508: 2010	

### Features

- Closed loop (compensated) current transducer using the Hall effect
- Insulating plastic case recognized according to UL 94-V0.

### Advantages

- Excellent accuracy
- Very good linearity
- Low temperature drift
- Optimized response time
- Wide frequency bandwidth
- No insertion losses
- High immunity to external interference
- Current overload capability.

### Applications

- AC variable speed drives and servo motor drives
- Static converters for DC motor drives
- Battery supplied applications
- Uninterruptible Power Supplies (UPS)
- Switched Mode Power Supplies (SMPS)
- Power supplies for welding applications.

### Application domain

- Industrial.

Notes:<sup>1)</sup> Result of the coercive field of the magnetic circuit

<sup>2)</sup> With a  $di/dt$  of 100 A/µs.

## Current Transducer LT 508-S6

### Insulation coordination

$U_d$	Rms voltage for AC insulation test, 50 Hz, 1 min	4.95 <sup>1)</sup>	kV
$\hat{U}_W$	Impulse withstand voltage 1.2/50 $\mu$ s	9.1	kV
		Min	
$d_{Cp}$	Creepage distance <sup>2)</sup>	25.8	mm
$d_{Cl}$	Clearance <sup>2)</sup>	11.5	mm
CTI	Comparative tracking index (group IIIa)	275	

Notes: <sup>1)</sup> Between primary and secondary

<sup>2)</sup> On housing.

### Applications examples

According to EN 50178 and IEC 61010-1 standards and following conditions:

- Over voltage category OV 3
- Pollution degree PD2
- Non-uniform field

	EN 50178	IEC 61010-1
$d_{Cp}, d_{Cl}, \hat{U}_W$	Rated insulation voltage	Nominal voltage
Basic insulation	600 V	600 V
Reinforced insulation	300 V	300 V

### Safety

This transducer must be used in limited-energy secondary circuits according to IEC 61010-1.



This transducer must be used in electric/electronic equipment with respect to applicable standards and safety requirements in accordance with the manufacturer's operating instructions.



Caution, risk of electrical shock

When operating the transducer, certain parts of the module can carry hazardous voltage (eg. primary busbar, power supply).

Ignoring this warning can lead to injury and/or cause serious damage.

This transducer is a build-in device, whose conducting parts must be inaccessible after installation.

A protective housing or additional shield could be used.

Main supply must be able to be disconnected.

## Dimensions LT 508-S6 (in mm)

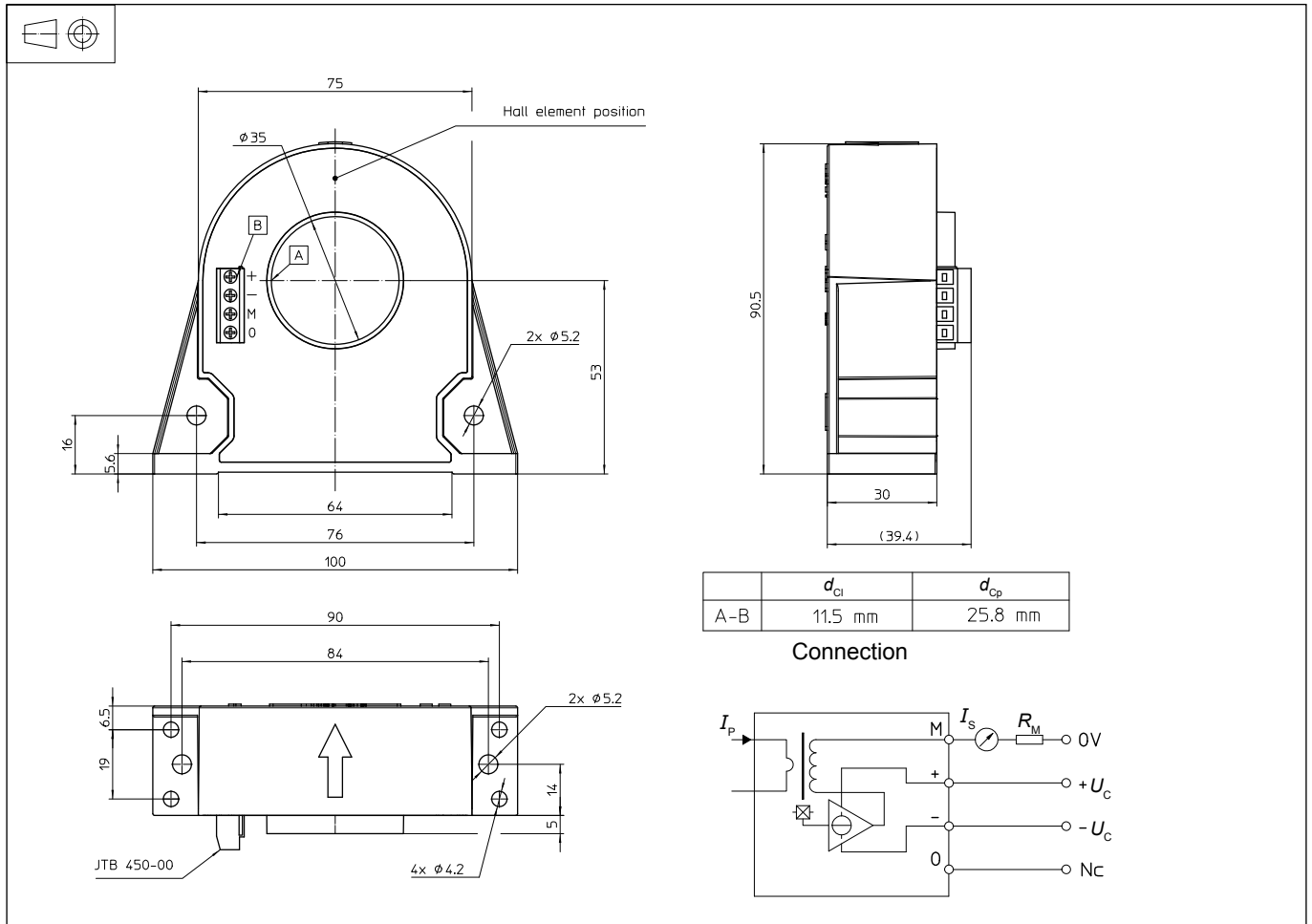

### Mechanical characteristics

- General tolerance  $\pm 0.6$  mm
- Transducer fastening
  - Horizontal position
    - 2 holes  $\phi 5.2$  mm
    - 2 M5 steel screws
  - Recommended fastening torque or
    - 1.5 N·m
    - 4 holes  $\phi 4.2$  mm
    - 4 M4 steel screws
  - Recommended fastening torque
    - 0.75 N·m
- Vertical position
  - 2 holes  $\phi 5.2$  mm
  - 2 M5 steel screws
  - Recommended fastening torque
    - 1.5 N·m
- Primary through-hole  $\phi 35$  mm
- Connection of secondary Socket JTB 450-00 (Jite, Shenzhen)

### Remarks

- $I_s$  is positive when  $I_p$  flows in the direction of the arrow.
- Temperature of the primary conductor should not exceed 100 °C.
- Installation of the transducer must be done unless otherwise specified on the datasheet, according to LEM Transducer Generic Mounting Rules. Please refer to LEM document N°ANE120504 available on our Web site: [Products/Product Documentation](#).
- Dynamic performances ( $di/dt$  and response time) are best with a single bar completely filling the primary hole.
- This is a standard model. For different versions (supply voltages, turns ratios, unidirectional measurements...), please contact us.