

TER	ANG.	0° (▨=NO)			
		(20°)	(15°)	(15°)	(20°)
①		▨			
②				▨	
③		▨	▨	▨	▨

CCW ← → CW

CODE TABLE

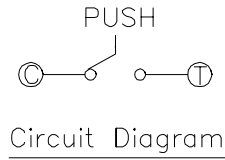

NOTE:

Operating Force:
 lever portion 100 ± 30 gf
 Push portion 205 ± 50 gf

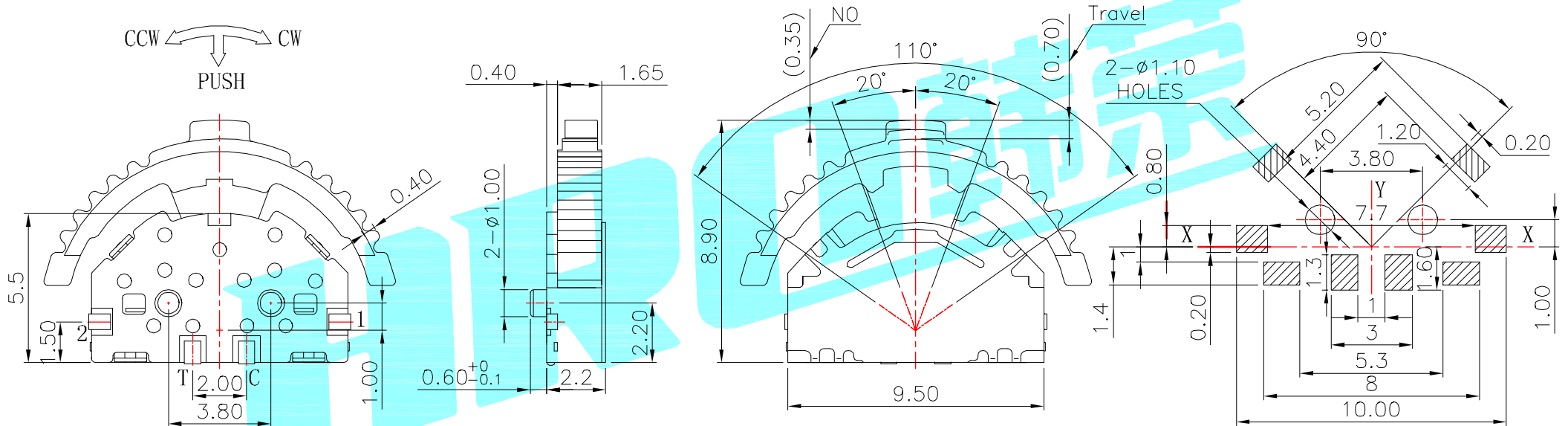

P.C.B Mounting
 Pattern Dimension

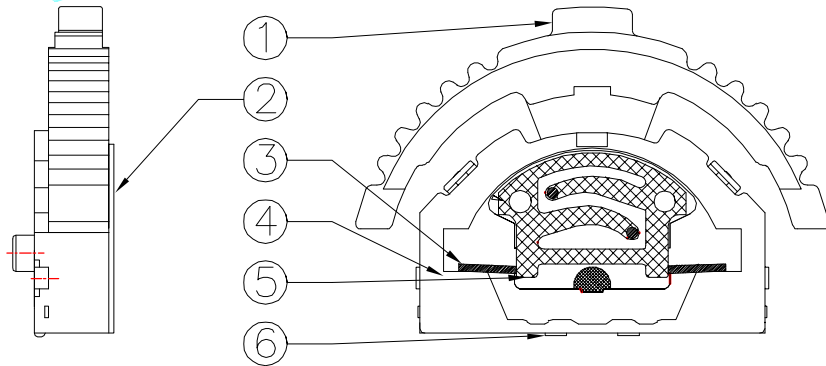

ITEM	PART NAME	TER'NO.	QTY.	MATERIAL	FINISHING	REMARK
⑥	Contact	—	1	F.Ag/Brass	—	—
⑤	Terminal	—	4	Brass(0.15t)	Plating silver	—
④	Base	—	1	Nylon	Black	—
③	Spring	—	1	SUS	—	—
②	Cover	—	1	SUS	White	—
①	Keystoke	—	1	Nylon	Black	—

APPROVALS		DATE		HRO 弘毅 ELECTRONICS CO.,LTD		
DRAWN	J.X.Zhang	2013/8/6		TITLE:	MULTIFUNCTIONAL SWITCHES	
CHECKED				PART NO.	K1-1519SA-01	
APPROVALS				UNIT: mm	SCALE: 1:1	PROJ:
TOLERANCES ARE		30~以上	±0.30	ANGLE	DRAWING NO.	SHEET 1 OF 1
		10~30	±0.20			
		5~10	±0.15			
		~ 5	±0.10			

ECN NO.	REV.	DATE.	DESCRIPTION.	CHANGE.	CHECK.	APPRO.
	A		NEW			