

**ROHS**

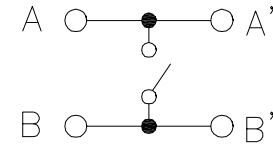

Circuit Diagram

NO.1	
PART NO	vigor
3	180±30
4	250±30

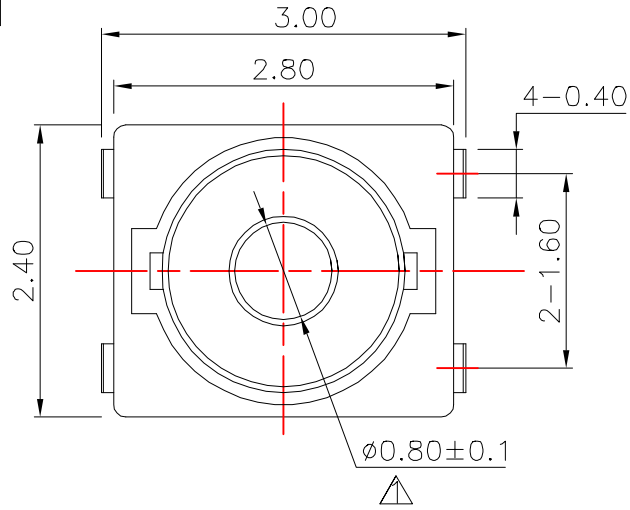
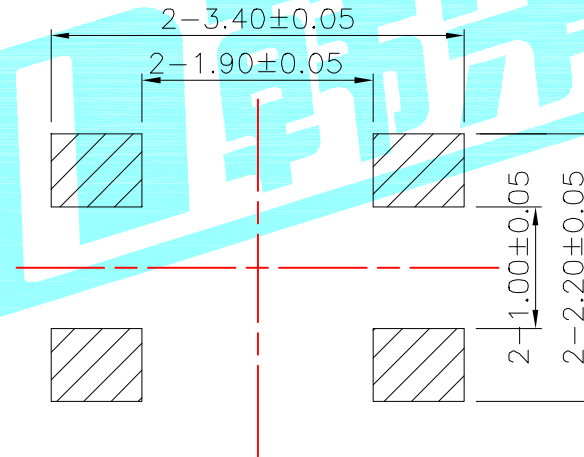
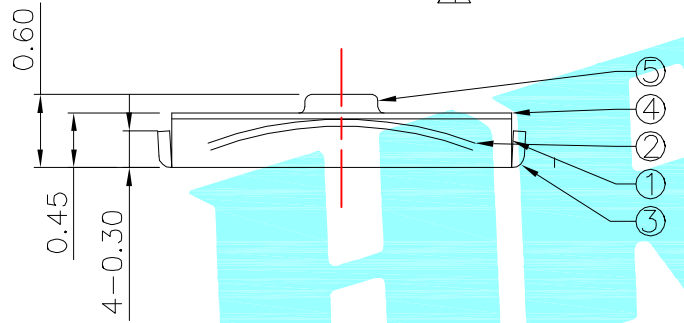

PCB Layout (Pattern Side)

NO.2	
PART NO	MATERIAL/QTY
S	SUS/1PC
D	SUS/2PCS

NO.3-NO.4	
PART NO	NOTE
01~99	SERIAL NUMBER

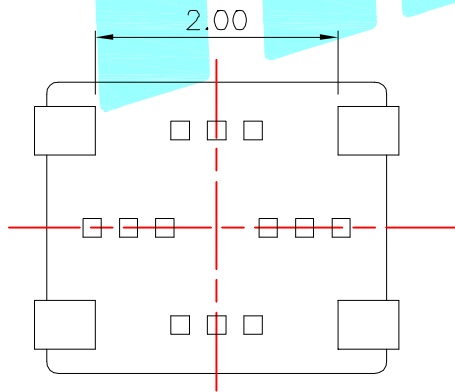

Note:  
Travel:0.15±0.05mm

⑤	Knob	—	1	PET	Black	—
④	Dust cover	—	1	KAPTON FILM	Yellow	—
③	Terminal	—	4	Phosphor Bronze	Plating silver	—
②	Contact	—	2	F.Ag/SUS	Plating silver	—
①	Base	—	1	Nylon	Black	—
ITEM	PART NAME	TER'NO.	QTY.	MATERIAL	FINISHING	REMARK

APPROVALS		DATE		 ELECTRONICS CO.,LTD		
DRAWN	JIANKUN.LU	2015.03.30				
CHECKED				TITLE: TACT SWITCHS		
APPROVALS				PART NO. K2-1836UQ-C□□W-□□		
TOLERANCES ARE		30~以上	±0.30	ANGLE	UNIT: mm	SCALE: 1:1
		10~30	±0.20			
		5~10	±0.15			
		~ 5	±0.10			
				±2'	DRAWING NO.	PROJ:
				SHEET 1 OF 1		

—	B	—	 NEW	—	—	—
—	A	—		—	—	—
ECN NO.	REV.	DATE.	DESCRIPTION.	CHANGE.	CHECK.	APPRO.