

Description

The DC1LIN is an asymmetrical line protection transient voltage suppressor array, designed for local interconnect network(LIN) bus protection. This device is available in a bidirectional configuration and is rated at 200W for an 8/20 μ s waveshape.

The DC1LIN meets IEC61000-4-2(ESD) and IEC 61000-4-4(EFT) requirements.

Mechanical Characteristics

- ◆ Package: SOD-323
- ◆ Approximate Weight: 5 milligrams
- ◆ Lead-Free Pure-Tin Plating (Annealed)
- ◆ Solder Reflow Temperature:
Pure-Tin -Sn, 100: 260-270°C
- ◆ UL Flammability Classification Rating 94V-0
- ◆ Terminal Connections: See Diagram Below
- ◆ Marking Information: See Below

Features

- ◆ AEC-Q101 Qualified
- ◆ Complies with following standards:
 - IEC 61000-4-2 (ESD) immunity test
Air discharge: ± 30 kV
Contact discharge: ± 30 kV
 - IEC61000-4-4 (EFT) 40A (5/50ns)
 - IEC61000-4-5 (Surge) : 24A(8/20 μ s) – Level 2 (Line-Gnd) & Level 3 (Line-Line)
- ◆ 200W Peak Pulse Power per Line (tp=8/20 μ s)
- ◆ Replacement for MLV (0805)
- ◆ Bidirectional Configuration
- ◆ Protects One Power or I/O Port
- ◆ Low Clamping Voltage
- ◆ Asymmetrical Line Protection: Pin1 to 2 -15V, Pin2 to 1 -24V
- ◆ RoHS Compliant
- ◆ REACH Compliant

Applications

- ◆ Automotive Applications
- ◆ Local Interconnect Network (LIN) Bus Protection
- ◆ Bus Protection

Dimensions and Pin Configuration

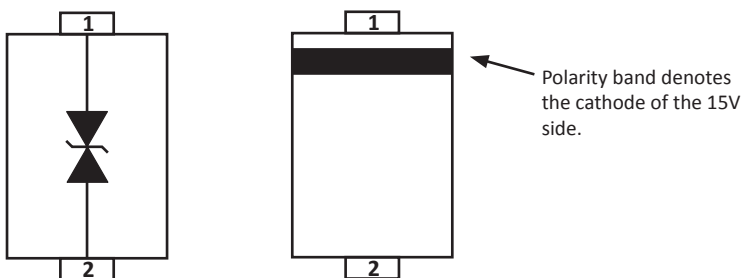

Marking Information



54 = Device Marking Code

Ordering Information

Part Number	Marking	Packaging	Reel Size
DC1LIN	54	3000/Tape & Reel	7 inch

Absolute Maximum Ratings ($T_A=25^{\circ}\text{C}$ unless otherwise specified)

Parameter	Symbol	Value	Unit
Peak Pulse Power ($t_p=8/20\mu\text{s}$)	PPP	200	W
ESD per IEC 61000-4-2 (Air)	VESD	± 30	kV
ESD per IEC 61000-4-2 (Contact)		± 30	
Operating Temperature Range	TJ	-55 to +125	$^{\circ}\text{C}$
Storage Temperature Range	Tstg	-55 to +150	$^{\circ}\text{C}$

Electrical Characteristics ($T_A=25^{\circ}\text{C}$ unless otherwise specified)

	Rated Stand-off Voltage V_{RWM} (V)	Breakdown Voltage @5mA V_{BR} (V)			Clamping Voltage @ $I_P=1\text{A}$ V_C (V)		Clamping Voltage @8/20 μs $V_C@I_{PP}$ (V)		Maximum Leakage Current ($T_J=25^{\circ}\text{C}$) @ V_{RWM} I_D μA		Maximum Differential Resistance @ $I_R=1\text{mA}$ OHMS	Off-state Capacitance @0Vdc, 1MHz C (pF)	
		Min	Typ	Max	Typ	Max	Typ	Max	Typ	Max		Typ	Max
		Pin 1 to 2	15.0	17.2	19	22	20.5	25	30	44@5A		0.001	0.045
Pin 2 to 1	24.0	25.5	31	36	37	40	55	70@3A	0.001	0.045	300	14	17

Typical Performance Characteristics (TA=25°C unless otherwise Specified)

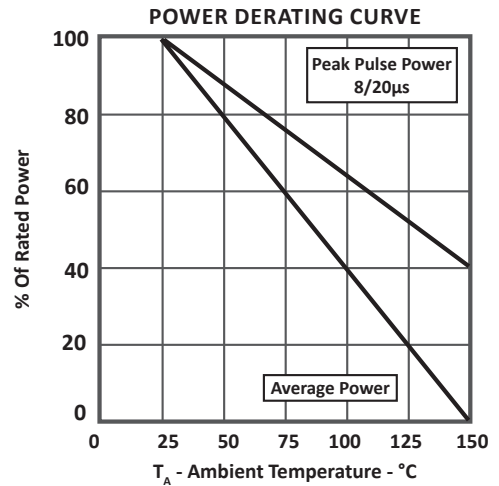
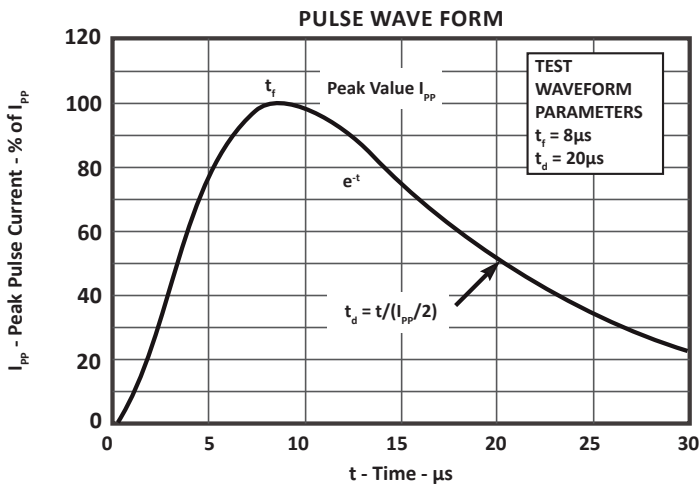
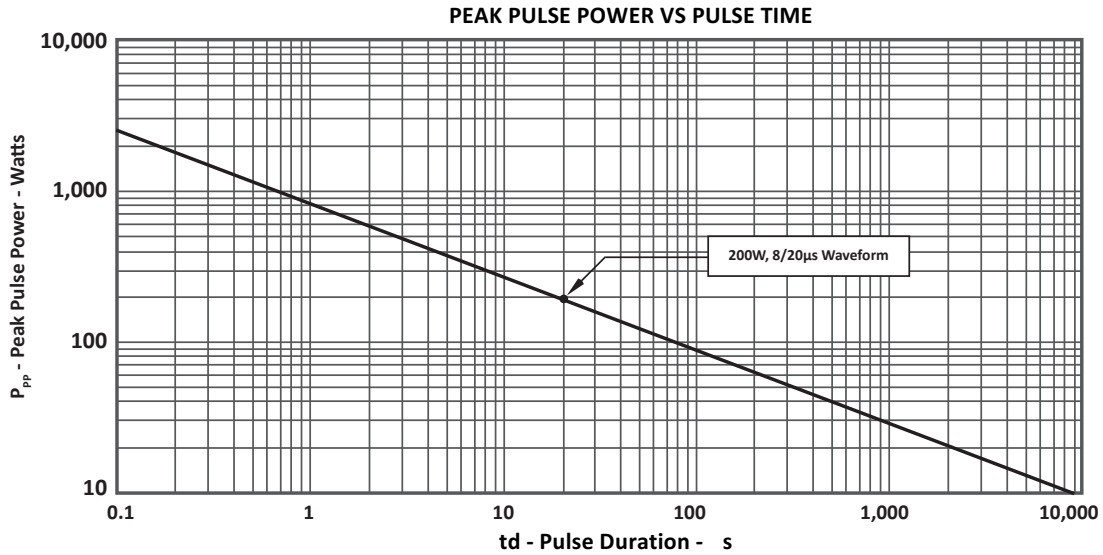

Typical Performance Characteristics (TA=25°C unless otherwise Specified)

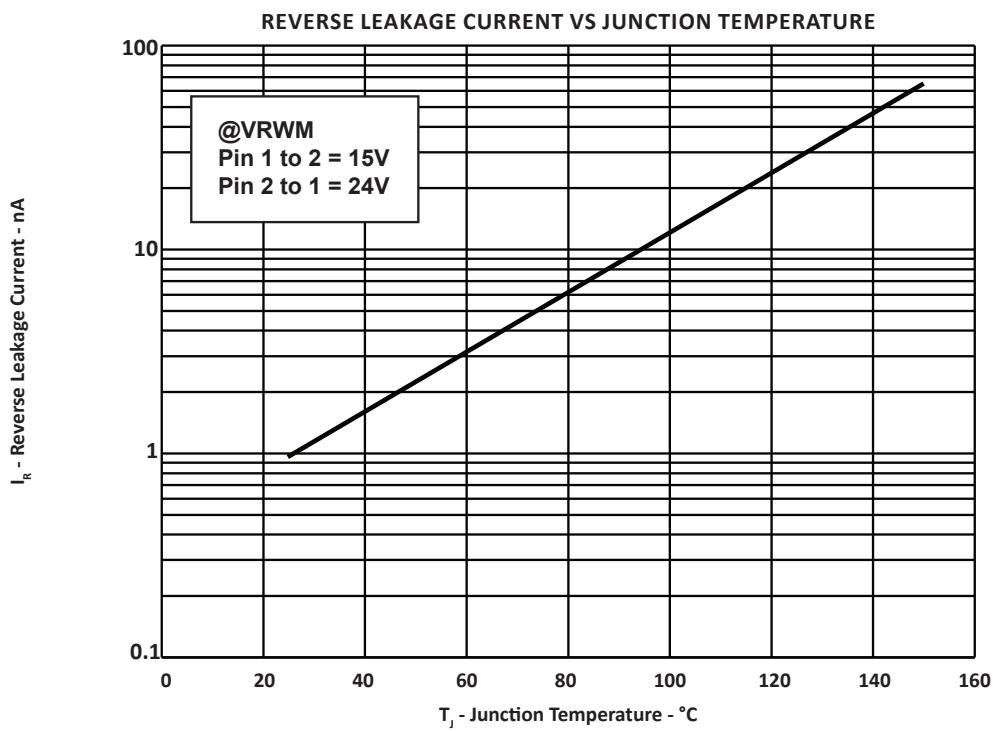
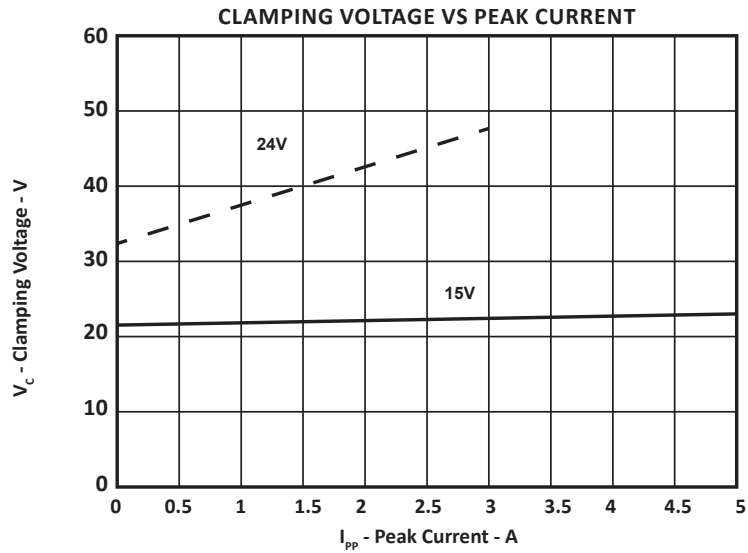

SOD-323 Package Outline Drawing

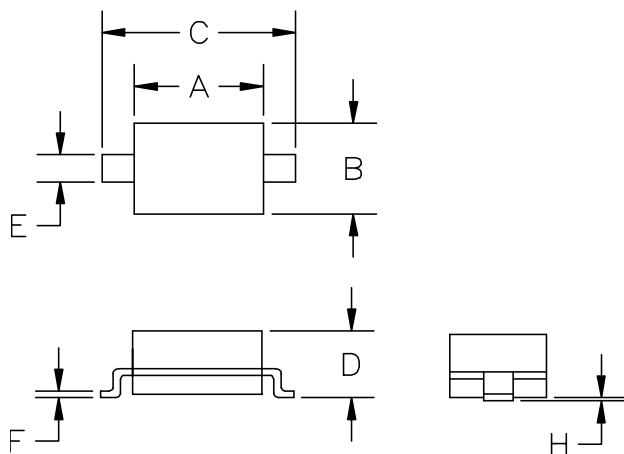

SYM	DIMENSIONS			
	MILLIMETERS		INCHES	
	MIN	MAX	MIN	MAX
A	1.50	1.80	0.060	0.071
B	1.20	1.40	0.045	0.054
C	2.30	2.70	0.090	0.107
D	-	1.10	-	0.043
E	0.30	0.40	0.012	0.016
F	0.10	0.25	0.004	0.010
H	-	0.10	-	0.004

Suggested Land Pattern

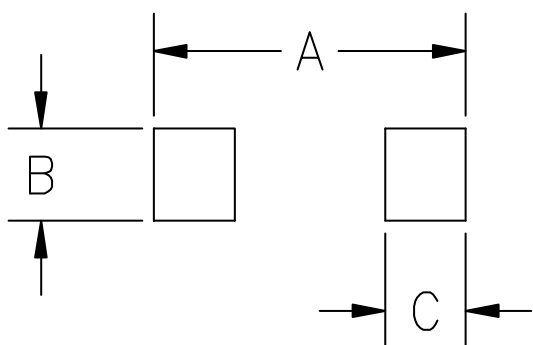

SYM	DIMENSIONS	
	MILLIMETERS	INCHES
A	3.15	0.120
B	0.80	0.031
C	0.80	0.031

Contact Information

Changzhou D-first Electronics CO.,Ltd.

www.first-electronic.com

Email: yf@first-electronic.cn

Phone: +86 (0519) 8817 1671