

### PACKING DIMENSIONS (mm)

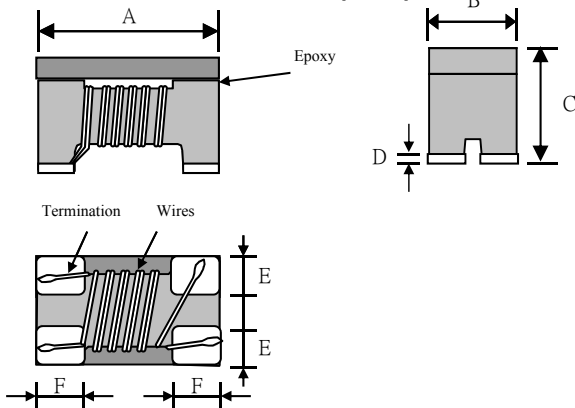

3225	Dimensions
A	3.2 ± 0.2
B	2.5 ± 0.2
C	2.2 ± 0.2
D	0.2 ± 0.1
E	0.80 Typ
F	0.65 Typ

### EXPLANATION OF PART NUMBERS

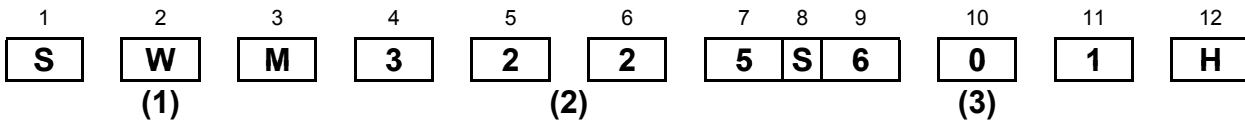

- (1) Product name
- (2) Shapes and dimensions
- (3) Impedance 【 at 100MHz 】  
601:600Ω

### ELECTRICAL CHARACTERISTICS

P/N	Z(Ω)	DCR (Ω)	Rated current	Rated Voltage	Insulation Resistance
	Common Mode				
	Impedance	[ Max ]	Idc(A)	Vdc	IR
	at 100MHz	[ Max ]	[ Max ]	(V)Typical	(MΩ)Min.
SMW3225S601HTE	600	0.25	1	50	10

Operating temperature : -25 to +85°C

Storage temp. and humidity : -40 to +85°C ,70%RH max

Typical Heat Rating DC Current would cause an approximately ΔT of 40°C

### Recommended Footprint(mm)

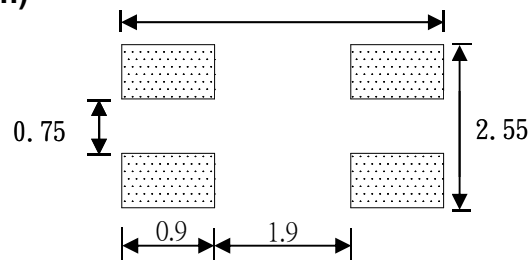

## PERFORMANCE CURVES

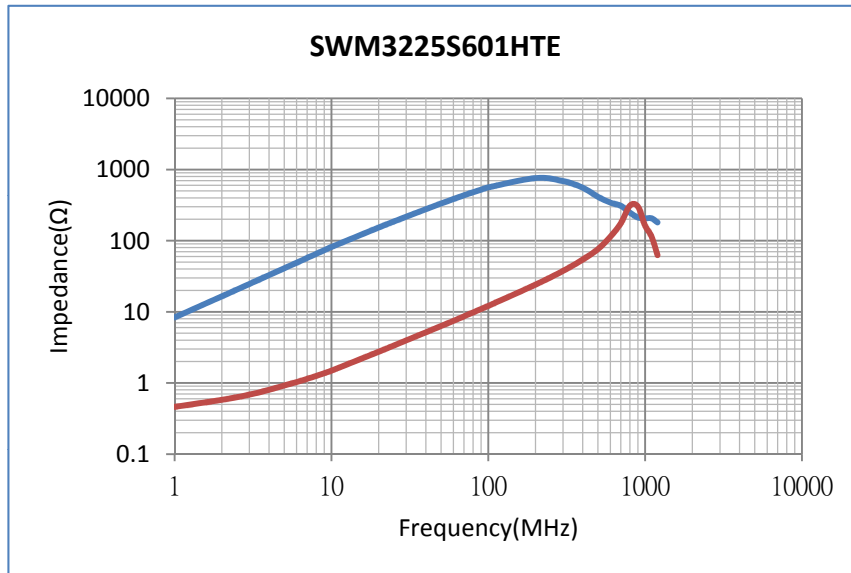

**Test Equipment**

**Impedance**

Measured by using Agilent 4291A RF Impedance Analyzer.

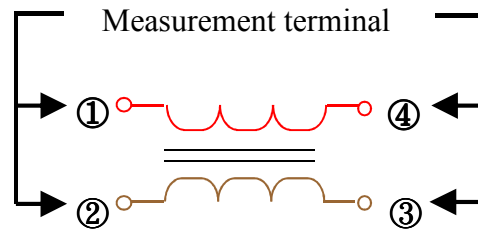

**DC Resistance**

Measurement terminal

Measured by using Chroma 16502 mill ohm meter.

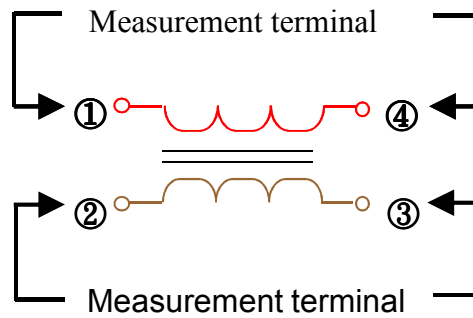

**Insulation Resistance**

Measured by using Chroma 19073

Measurement voltage : 50v ,Measurement time : 60 sec.

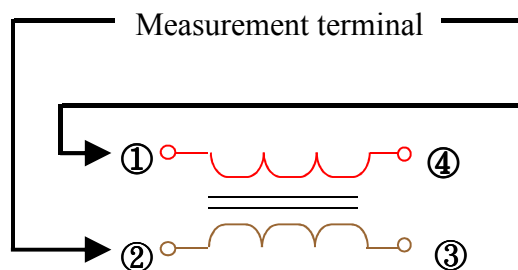

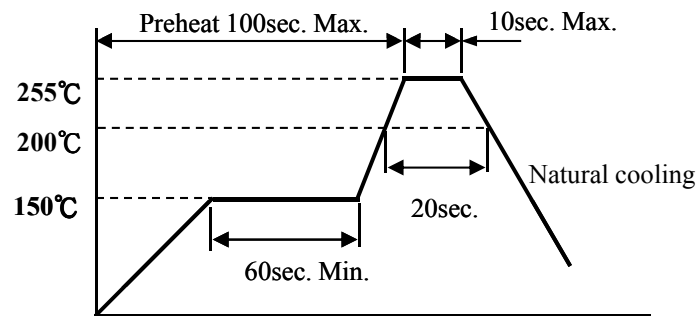
**RECOMMENDED SOLDERING TEMP. GRAPH**

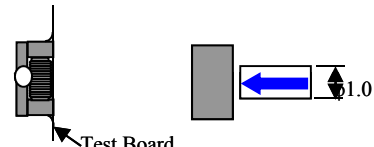
**MECHANICAL RELIABILITY**

TEST	Specification & Requirement	Method Used
Solderability	The surface of terminal/pin tested shall be covered with new solder by 90%	Solder heat proof: Preheating: 150 ±10°C 60 seconds Soldering: 245 ±5°C for 4 ±1 sec
Solder Heat Resistance	Components should have not evidence of electrical and mechanical damage Impedance: within ±15% of initial value	Preheating: 150°C 60secs Solder temperature: 260±5°C Flux: rosin Dip time: 10±0.5 secs
Terminal strength	Series No.	F (Kg)
	1608	0.5
	2012	0.5
	3216	1.0
	3225	1.0
		 <p>Solder a chip to test substrate and then laterally apply a force in the arrow direction</p>

**ENDURANCE RELIABILITY**

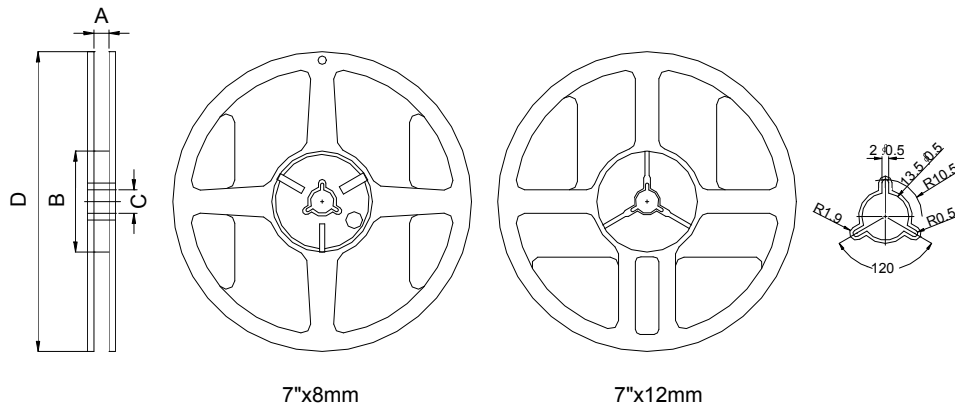
TEST	Specification & Requirement	Method Used
Thermal Shock	Impedance change within ± 15% Without mechanical damage	-65°C, (30 mins) -> room temp. (2 mins) -> 125°C, (30 mins) -> room temp. (2 mins) 50 cycles
Humidity Resistance	Impedance change within ± 15% Without mechanical damage	Apply IDC current @ 60°C ambient Humidity: 90% Duration: 168 hrs
Low Temp. Storing	Impedance change within ± 15% Without mechanical damage	Storing Temp. -40 ±2 °C for total 168 +5/-0 hours
High Temp. Storing	Impedance change within ± 15% Without mechanical damage	Storing Temp. 125 ±2 °C for total 168 +5/-0 hours

**Reel Dimension & Tape Dimension**

Type	A(mm)	B(mm)	C(mm)	D(mm)
7''x8mm	9.0±0.5	60±2	13.5±0.5	178±2
7''x12mm	13.5±0.5	60±2	13.5±0.5	178±2

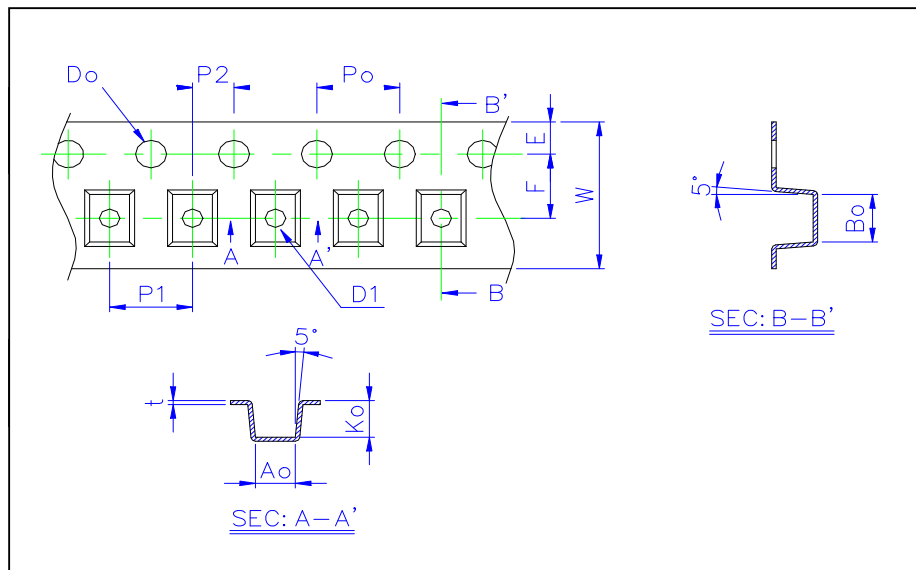

Size	Ao(mm)	Bo(mm)	Ko(mm)	W(mm)	E(mm)	F(mm)	Po(mm)	P1(mm)	Do(mm)
1608	1.65±0.10	1.00±0.10	1.18±0.10	8.00±0.20	1.75±0.10	3.50±0.05	4.0±0.05	4.0±0.10	none
2012	2.35±0.10	1.50±0.10	1.45±0.10	8.00±0.20	1.75±0.10	3.50±0.05	4.0±0.05	4.0±0.10	1.0±0.1
3216	3.50±0.10	1.88±0.10	2.10±0.10	8.00±0.20	1.75±0.10	3.50±0.05	4.0±0.05	4.0±0.10	1.0±0.1
3225	3.60±0.10	2.80±0.10	2.20±0.10	8.00±0.20	1.75±0.10	3.50±0.05	4.0±0.05	4.0±0.10	1.0±0.1

**Packaging Quantity**

Chip Size	3225
8mm/ Reel	1000