

Electrostatic Discharged Protection Devices (ESD) Data Sheet

Description

Brightking's SDT23C712L02 component is designed for asymmetrical (12V to -7V) protection in multi-point data transmission standard RS-485 applications. It may be used to protect devices from transient voltages resulting from electrostatic discharge (ESD), electrical fast transients (EFT), and lightning. It features 400W (tp=8/20µs) of power handling capability to accommodate the higher transient voltage levels which may be expected in extended common mode applications.



Contact : ±30kV
Air : ±30kV



Features

- IEC61000-4-2 ESD 30KV Air, 30KV contact compliance
- SOT-23 surface mount package
- Protects two +12V to -7V lines
- Peak power dissipation of 400W under 8/20µs waveform
- Low leakage current
- Low clamping voltage
- Solid-state silicon avalanche technology
- Lead Free/RoHS compliant
- Solder reflow temperature: Pure Tin-Sn, 260~270°C
- Flammability rating UL 94V-0
- Meets MSL level 1, per J-STD-020
- Marking: B 712

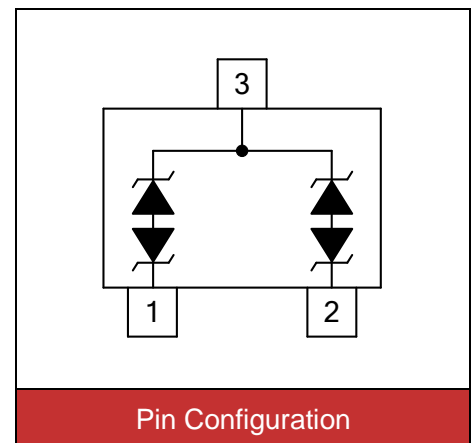

Applications

- Protection of RS-485 transceiver with extended Common-mode range
- Security Systems
- Automatic Teller Machines
- HFC Systems
- Networks

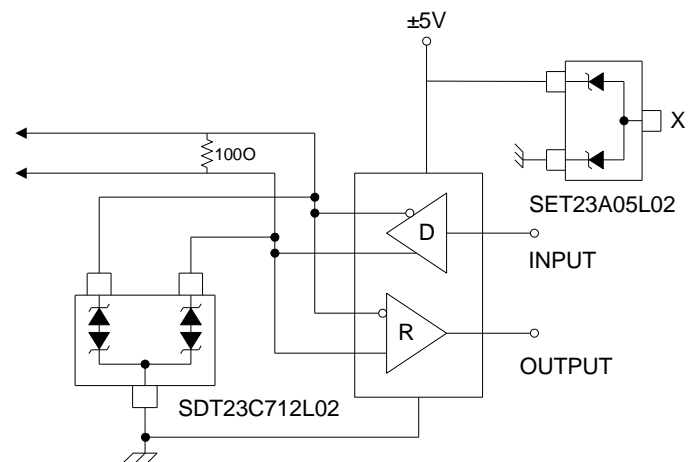

Maximum Ratings

Rating	Symbol	Value	Unit
Peak pulse power (tp=8/20μs waveform)	P _{PP}	400	W
ESD voltage (Contact discharge)	V _{ESD}	±30	kV
ESD voltage (Air discharge)		±30	
Storage & operating temperature range	T _{STG} , T _J	-55~+150	°C

Electrical Characteristics (T_J=25°C)

Pin 1 to Pin3 and Pin2 to Pin3

Parameter	Symbol	Condition	Min.	Typ.	Max.	Unit
Reverse stand-off voltage	V _{RWM}				12	V
Reverse breakdown voltage	V _{BR}	I _{BR} =1mA	13.3			V
Reverse leakage current	I _R	V _R =12V			1	μA
Clamping voltage (tp=8/20μs)	V _C	I _{PP} =5A			20	V
Peak Pulse Current(tp=8/20μs)	I _{PP}				15	A
Off state junction capacitance	C _J	0Vdc, f=1MHz Between I/O pins and GND			75	pF

Pin 3 to Pin1 and Pin3 to Pin2

Parameter	Symbol	Condition	Min.	Typ.	Max.	Unit
Reverse stand-off voltage	V _{RWM}				7	V
Reverse breakdown voltage	V _{BR}	I _{BR} =1mA	7.5			V
Reverse leakage current	I _R	V _R =7V			20	μA
Clamping voltage (tp=8/20μs)	V _C	I _{PP} =5A			10	V
Peak Pulse Current(tp=8/20μs)	I _{PP}				15	A
Off state junction capacitance	C _J	0Vdc, f=1MHz Between I/O pins and GND			75	pF

Typical Characteristics Curves

Figure 1. Power Derating Curve

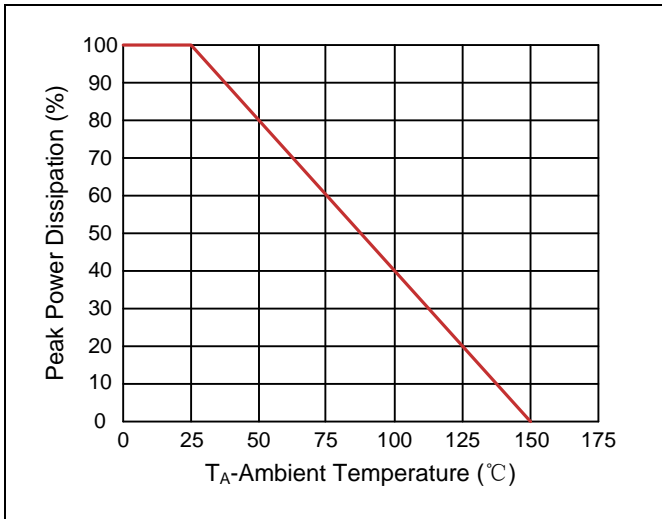

Figure 2. Pulse Waveforms

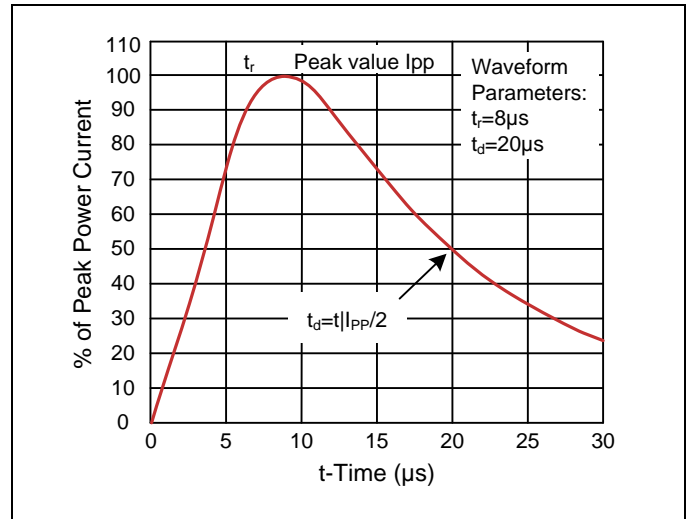

Figure 3. Non-Repetitive Peak Pulse vs. Pulse Time

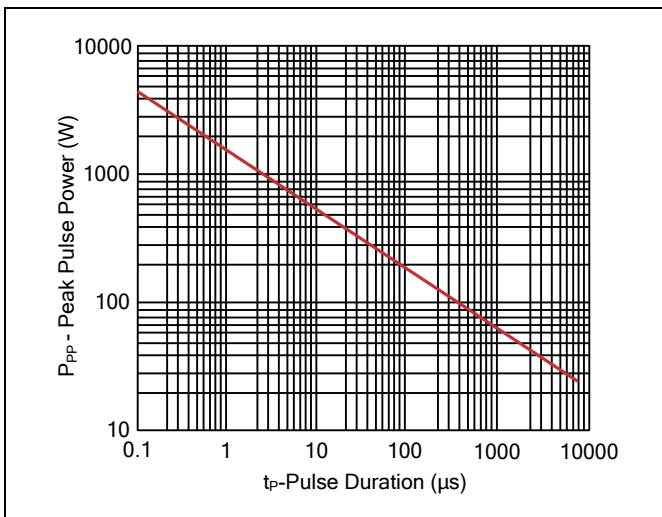
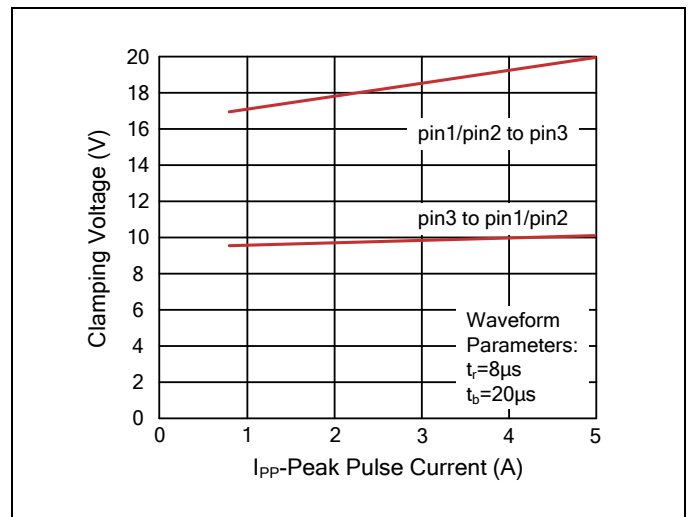
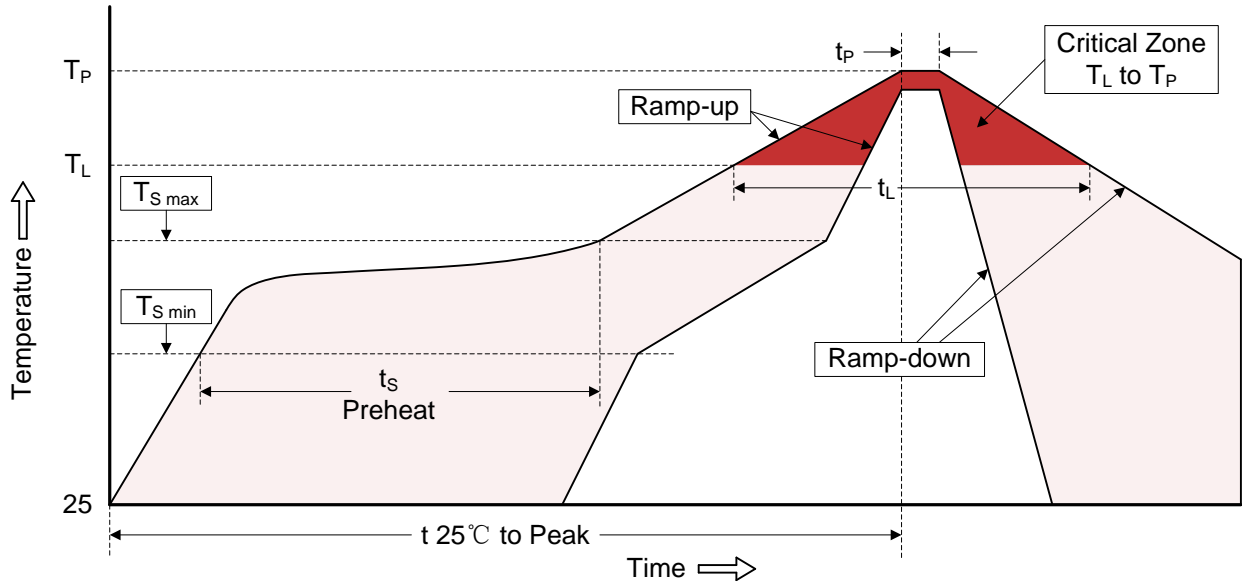

Figure 4. Clamping Voltage vs. Peak Pulse Current



Recommended Soldering Conditions

Reflow Soldering



Recommended Conditions

Profile Feature	Pb-Free Assembly
Average ramp-up rate (T_L to T_P)	3°C/second max.
Preheat -Temperature Min ($T_{S\ min}$) -Temperature Max ($T_{S\ max}$) -Time (min to max) (t_s)	150°C 200°C 60-180 seconds
$T_{S\ max}$ to T_L -Ramp-up Rate	3°C/second max.
Time maintained above: -Temperature (T_L) -Time (t_L)	217°C 60-150 seconds
Peak Temperature (T_P)	260°C
Time within 5°C of actual Peak Temperature (t_P)	20-40 seconds
Ramp-down Rate	6°C/second max.
Time 25°C to Peak Temperature	8 minutes max.

Dimensions (SOT-23)

Symbol	Dimension			
	Millimeters		Inches	
	Min.	Max.	Min.	Max.
A	0.08	0.18	0.003	0.007
B	0.15	-	0.006	-
C	-	0.13	-	0.005
D	0.89	1.09	0.035	0.043
E	2.80	3.05	0.110	0.120
F	1.90		0.075	
G	0.95		0.037	
H	1.19	1.40	0.047	0.055
I	2.10	2.49	0.083	0.098
J	0.35	0.50	0.014	0.020

Recommended Soldering Pad Layout

Packaging

Tape	Symbol	Dimension (mm)
	W	8.00±0.30
P0	4.00±0.10	
P1	4.00±0.10	
P2	2.00±0.10	
D0	Φ1.55±0.10	
D1	Φ1.00±0.05	
E	1.75±0.10	
F	3.50±0.10	
A	3.10±0.10	
A0	2.10±0.10	
B	2.75±0.10	
B0	0.65±0.10	
K	1.10±0.10	
t	0.20±0.05	

Reel	Symbol	Dimension (mm)
	D	Φ178.0±2.0
	D2	Φ13.0
	W1	9.5
		Quantity: 3000PCS