

PCB 继电器 JQC-22F系列产品规格书

- 16A switching capability
- SPST-NO configuration
- Small footprint
- Sealed version available
- Class B/F available
- Size 20.3mmX16.6mmX20.2mm (长*宽*高)



ORDERING CODE 订购代码

声明:本产品规格书仅供客户使用时参考,如有更改,恕不另行通知。

$\frac{\text{JQC-22F}}{1} - \frac{12\text{VDC}}{2} - \frac{\text{S}}{3} - \frac{\text{H}}{4}$	
1. Relay Model 继电器型号	3.S: Sealed 密封
2. Coil Nominal Voltage 线圈额定电压 5,6,9,12,18,24VDC	4. 触点转换形式 H: Form A Z: Form C D: Form B

COIL DATA 线圈参数 (at 20°C)

Nominal Voltage 额定电压 (VDC)	3	5	6	9	12	24	48	0.36W
Coil Resistance 线圈阻值 ($\Omega \pm 10\%$)	25	69	100	225	400	1600	6400	
Rated Current 额定电流 (mA)	120	71.4	60	40	30	15	7.5	
Max Operate Voltage 最大吸合电压 (VDC)	2.25	3.75	4.5	6.75	9	18	36	
Min Release Voltage 最小释放电压 (VDC)	0.15	0.25	0.3	0.45	0.6	1.2	2.4	0.45W
Coil Resistance 线圈阻值 ($\Omega \pm 10\%$)	20	56	80	180	320	1280	5120	
Rated Current 额定电流 (mA)	150	90	75	50	37.5	18.7	9	
Max Operate Voltage 最大吸合电压 (VDC)	2.25	3.75	4.5	6.75	9	18	36	
Min Release Voltage 最小释放电压 (VDC)	0.15	0.25	0.3	0.45	0.6	1.2	2.4	
Max Applicable Voltage 最大过载电压	70°C时额定电压的 130%, 23°C时额定电压的 170%							

CONTACT DATA 触点参数

Contact Form 触点形式	1H/1Z	
Contact Material 触点材料	Silver Alloy	
Load 负载	Resistive load (COS Φ =1)	
Contact Ratings 触点负载	1H:16A 250VAC 16A 30VDC	1Z:16A 250VAC 16A 30VDC
Minimum load 最小负载	10mA 5VDC	
Max Switching Voltage 最大转换电压	250VAC/30VDC	
Max Switching Current 最大转换电流	16A	
Max Switching Power 最大转换功率	4000VA/480W	
Contact Resistance 接触电阻	100m Ω Max at 6VDC 1A	
Life Expectancy 寿命	Electrical 电气寿命: 100,000 Operations (at 30 Operations/minute)	
	Mechanical 机械寿命: 10,000,000 Operations (at 300 Operations/minute)	

CHARACTERISTICS DATA 性能参数

Insulation Resistance 绝缘阻值	100MΩMin at 500VDC
Dielectric Strength Between Open Contacts 触点间耐压	750VAC(for one minute)
Between Contacts and coil 触点与线圈间耐压	1500VAC(for one minute)
Operate Time 吸合时间	10ms
Release Time 释放时间	5ms
Temperature Range 环境温度	-40°C to+85°C
Shock Resistance 冲击	Operating Extremes 动作极限 : 10G
	Damage Limits 破坏极限 : 100G
Vibration Resistance 振动	10-55Hz, 1.5mm
Max. switching frequency 最大转换频率	Mechanical:18,000operations/hr
	Electrical:1,800operations/hr
Humidity 湿度	40-85%
Weight 重量	Approx 13g

ENGINEERING DATA 设计参数

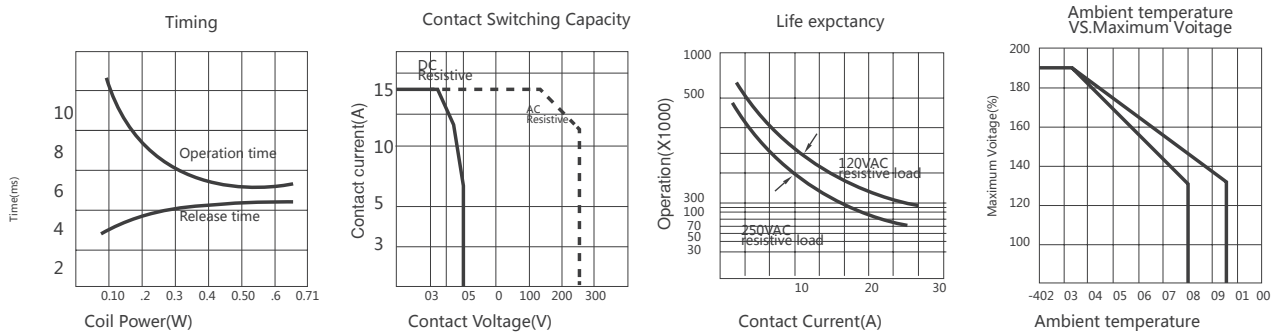

OVERALL AND MOUNTING DIMENSIONS 安装图

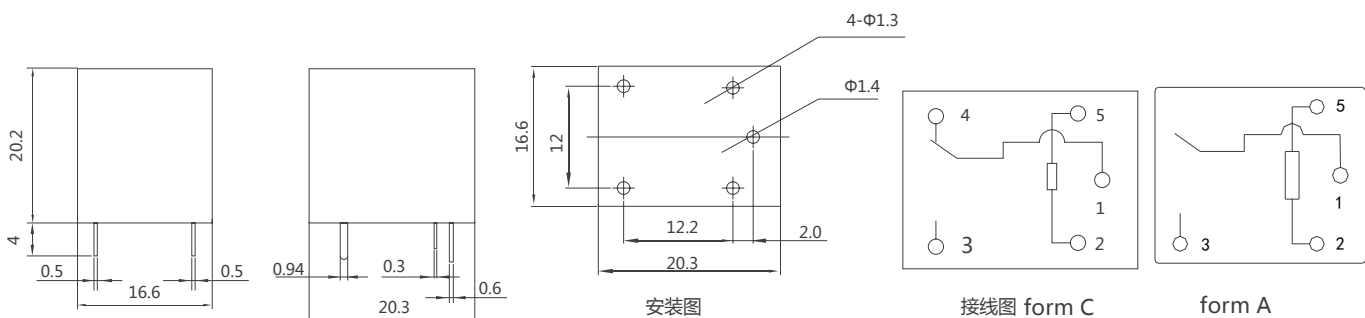

备注: 1) 产品部分外形尺寸中未注尺寸公差: 当外形尺寸≤ 1mm 时, 公差为 ±0.2mm;
当外形尺寸在 1~5mm 时, 公差为 ±0.3mm;
当外形尺寸 > 5mm 时, 公差为 ±0.4mm。
2) 安装孔尺寸中未注尺寸公差均为 ±0.1mm。

其他 Others

1、规格书内的各项性能参数是基于标准测试条件下测得的初始值。

All the performance data listed in the datasheet are the initial values tested under standard testing condition.

2、非塑封继电器需要防止助焊剂或污染物进入继电器。

Unsealed relays should be hand soldered to avoid flux contamination of the relay.

3、避免在强磁场条件下使用继电器，外界强磁场会造成继电器动作和释放等参数发生变化。

To avoid using relays under strong magnetic field because it will change the parameters of relay such as pull-in and drop-out voltage.

4、为了保持继电器的性能，请注意不要使继电器掉落或受到强冲击。掉落后的继电器建议不再使用。

To maintain the performances of relays, please do not make the relay drop or be shocked strongly. Suggest that the relays dropped not be used.