

PCB Layout (Pattern side)

Circuit Diagram

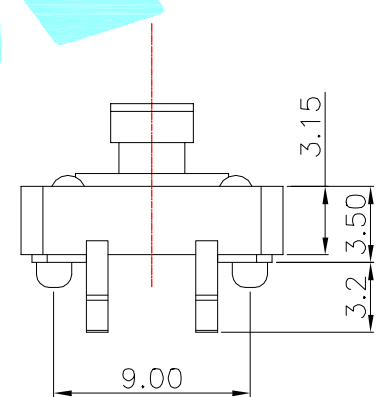
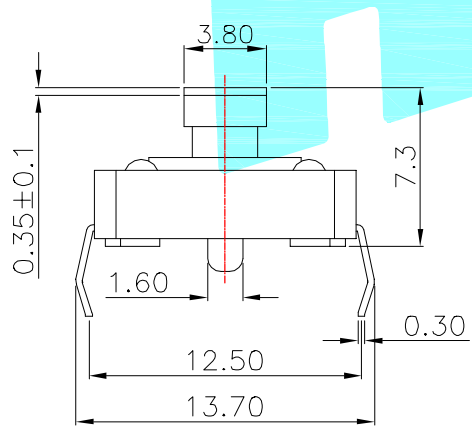

NO.1	
PART NO	vigor
1	90±30
2	130±30
3	180±30
4	250±30
5	350±50

NO.2	
PART NO	MATERIAL/QTY
S	SUS/1PC
C	C5210/1PC
D	SUS/2PCS
F	C5210/2PCS

NO.3-NO.4	
PART NO	NOTE
01~99	SERIAL NUMBER

⑤	Terminal	—	4	Brass(0.3t)	Plating silver	—
④	Contact	—	1	F.Ag/C5210	—	—
③	Base	—	1	Nylon	Black	UL94V-0
②	Cover	—	1	SPCC/Brass	Plating Sn	—
①	Keystoke	—	1	Nylon	Black	UL94V-0
ITEM	PART NAME	TER'NO.	QTY.	MATERIAL	FINISHING	REMARK

APPROVALS		DATE	HROELECTRONICS CO.,LTD			
DRAWN	J.X.Zhang	2014/2/18	TACT SWITCHS			
CHECKED			PART NO. K2-1103DT-A□□W-□□			
APPROVALS			UNIT: mm SCALE: 1:1 PROJ:			
TOLERANCES ARE		30~以上 ±0.30	ANGLE	DRAWING NO.		
		10~30 ±0.20		SHEET 1 OF 1		
		5~10 ±0.15				
		~ 5 ±0.10				

ECN NO.	REV.	DATE.	DESCRIPTION.	CHANGE.	CHECK.	APPRO.
	A		NEW			