

# SMF5.0A-LLC

Surface Mount Transient Voltage Suppressor Rectifiers  
Reverse Voltage 5.0 V  
200 Watt Peak Pulse Power

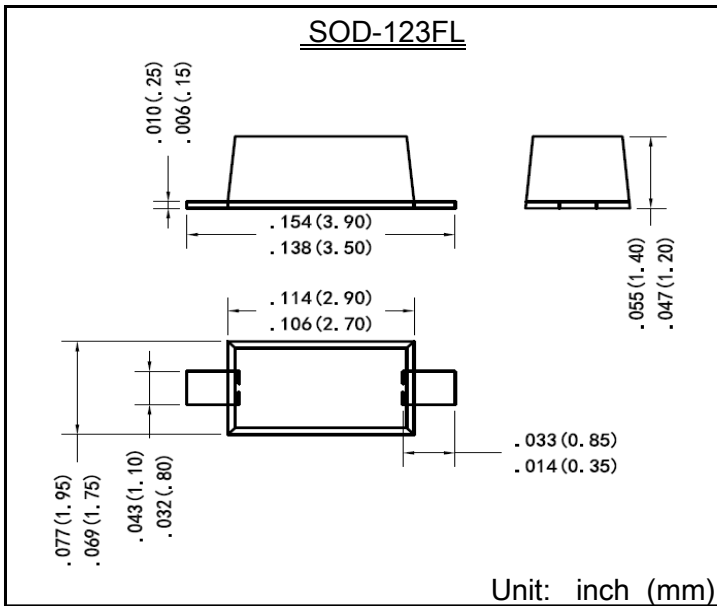

## Features

- Glass passivated chip
- 200 W peak pulse power capability with a 10/1000 us waveform, repetitive rate (duty cycle):0.01 %
- Excellent clamping capability
- Low reverse leakage
- Very fast response time
- Lead and body according with RoHS standard

## Mechanical Data

- Case: SOD-123FL Molded plastic
- Lead: Solderable per MIL-STD-750, method 2026
- Epoxy: UL 94V-0 rate flame retardant
- Polarity: Color band denotes cathode end except Bipolar
- Mounting position: Any

Maximum Ratings & Characteristics Ratings at 25°C ambient temperature unless otherwise specified.

Parameter	Symbols	Value	Unit
Peak power dissipation with a 10/1000 us waveform <sup>(1)</sup>	$P_{PP}$	200	W
Peak pulse current with a 10/1000 us waveform <sup>(1)</sup>	$I_{PP}$	21.74	A
Power dissipation on infinite heatsink at $T_L = 75^\circ\text{C}$	$P_D$	1.0	W
Peak forward surge current, 8.3 ms single half sine wave unidirectional only <sup>(2)</sup>	$I_{FSM}$	30	A
Maximum instantaneous forward voltage at 10 A for unidirectional only <sup>(3)</sup>	$V_F$	3.5	V
Operating junction and storage temperature range	$T_J, T_{STG}$	-55 to +150	°C

Note:

1) Non-repetitive current pulse per Fig.5 and derated above  $T_A = 25^\circ\text{C}$  per Fig.1 ;

2) Measured on 8.3 ms single half sine-wave or equivalent square wave, duty cycle = 4 pulses per minute maximum ;

3)  $V_F < 3.5\text{V}$  for devices of  $V_{BR} < 200\text{V}$  ;

Electrical Characteristics ( $T_A = 25^\circ\text{C}$  unless otherwise noted)

Part Number	Device Marking Code	Reverse Stand-off Voltage	Breakdown Voltage $V_{BR} @ I_T$		Test Current	Max. Clamping Voltage @ $I_{PP}$	Max. Peak Pulse Current	Max. Reverse Leakage @ $V_{RWM}$
			Min.(V)	Max.(V)				
UNI-POLAR	UNI	$V_{RWM}(V)$	Min.(V)	Max.(V)	$I_T(mA)$	$V_{C MAX}(V)$	$I_{PP}(A)$	$I_R(\mu A)$
SMF5.0A-LLC	FE	5.0	6.40	7.00	10	9.2	21.74	10

# SMF5.0A-LLC

## Ratings and Characteristics Curves (TA=25°C unless otherwise noted)

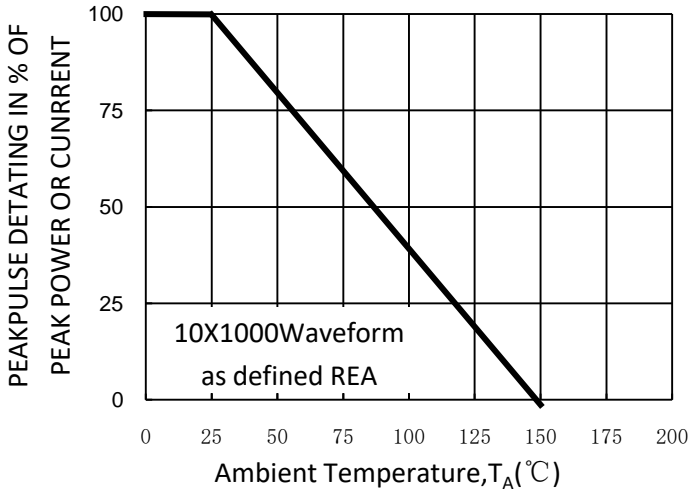

Fig. 1-Pulse Derating Curve

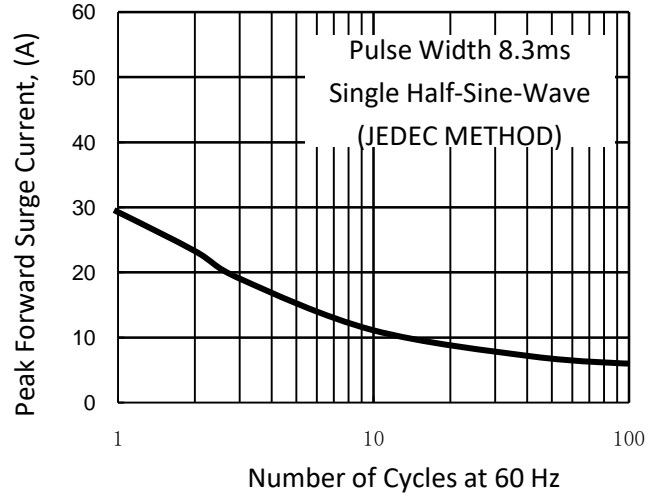

Fig. 2-Maximum Non-Repetitive Surge Current

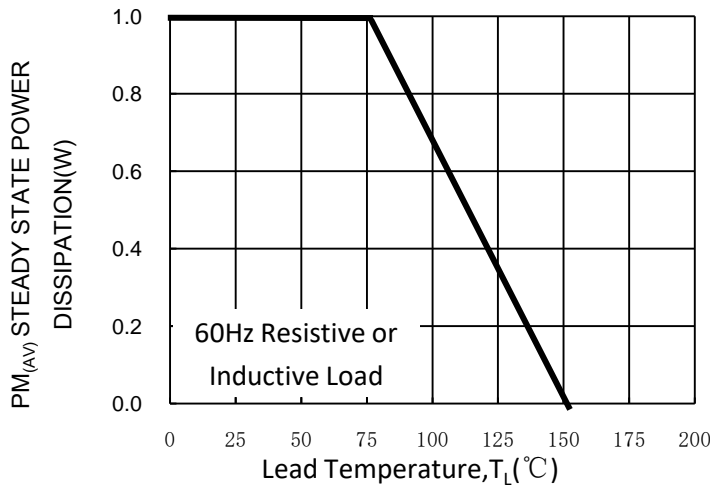

Fig. 3-Steady State Power Derating Curve

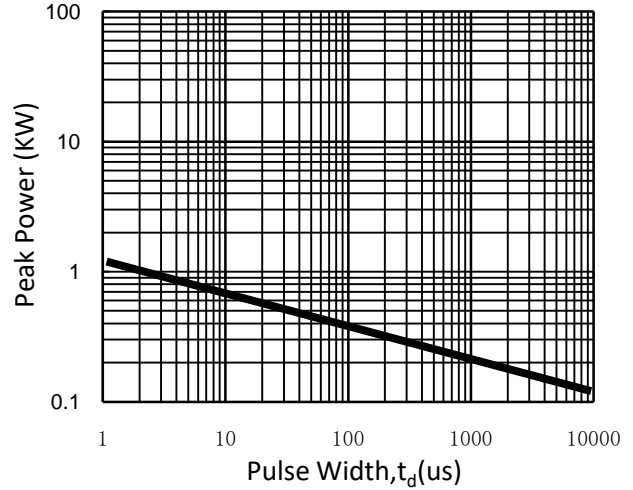

Fig. 4-Peak Pulse Power Rating Curve

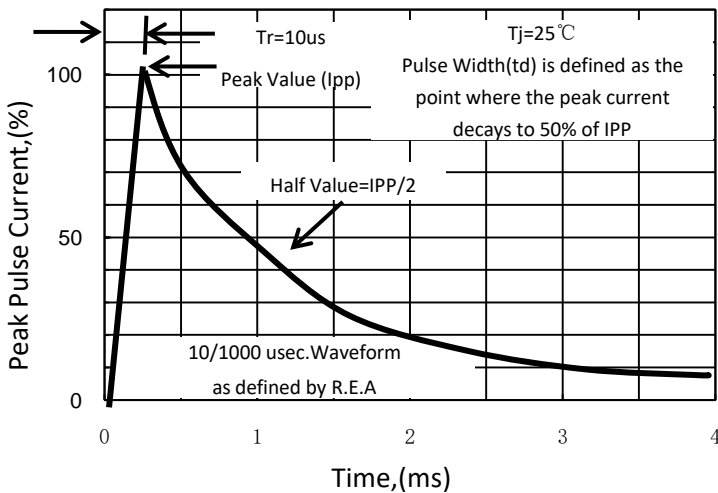

Fig. 5-Pulse Waveform

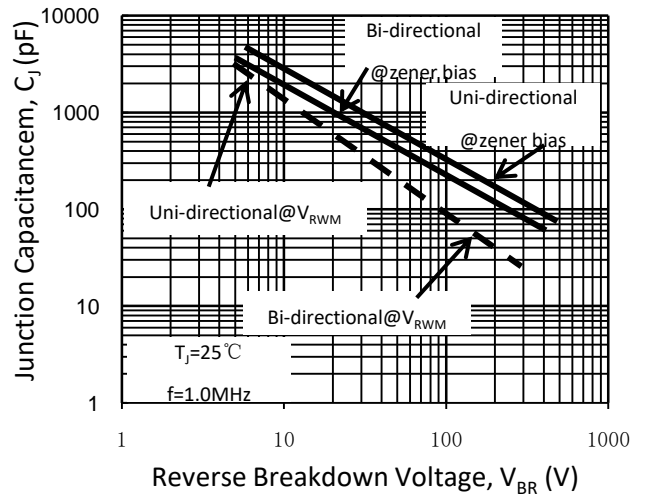

Fig. 6-Typical Junction Capacitance