

**Description**

The PDC3301D5 is an uni-directional TVS diode, utilizing leading monolithic silicon technology to provide fast response time and ultra low ESD clamping voltage, making this device an ideal solution for protecting voltage sensitive data and power line. The PDC3301D5 complies with the IEC 61000-4-2(ESD) with  $\pm 30\text{kV}$  air and  $\pm 30\text{kV}$  contact discharge. It is assembled into an ultra-small SOD-523 lead-free package. The small size and high ESD surge protection make PDC3301D5 an ideal choice to protect cell phone, digital cameras, audio players and many other portable applications.

**Features**

- Protects one data line
- Ultra low leakage: nA level
- Operating voltage: 3.3V
- Ultra low clamping voltage
- Complies with following standards:
  - IEC 61000-4-2 (ESD) immunity test Air discharge:  $\pm 30\text{kV}$
  - IEC61000-4-4 (EFT) 40A (5/50ns)
- ROHS Compliant

**Mechanical Characteristics**

- Package: SOD-523
- Lead Finish: Matte Tin
- Case Material: "Green" Molding Compound.
- Moisture Sensitivity: Level 3 per J-STD-020
- Terminal Connections: See Diagram Below
- Marking Information: See Below

**Applications**

- Cellular Handsets and Accessories
- Personal Digital Assistants
- Notebooks and Handhelds
- Portable Instrumentation
- Digital Cameras
- Peripherals
- Audio Players
- Keypads, Side Keys, LCD Displays

**Dimensions and Pin Configuration**

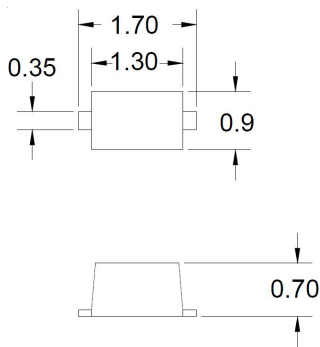

Package Dimensions

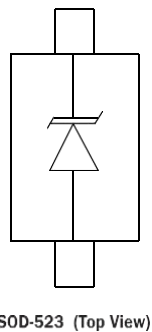

SOD-523 (Top View)

Circuit and Pin Schematic

**Marking Information**

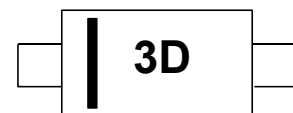

3D = Device Marking Code  
Bar denotes Pin1

**Ordering Information**

Part Number	Marking	Packaging	Reel Size
PDC3301D5	3D	3000/Tape & Reel	7 inch

**Absolute Maximum Ratings (TA=25°C unless otherwise specified)**

Parameter	Symbol	Value	Unit
Peak Pulse Power (8/20µs)	Ppk	150	W
Peak Pulse Current (8/20µs)	Ipp	15	A
ESD per IEC 61000-4-2 (Air)	VESD	±30	kV
ESD per IEC 61000-4-2 (Contact)		±30	
Operating Temperature Range	TJ	-55 to +125	°C
Storage Temperature Range	Tstg	-55 to +150	°C

**Electrical Characteristics (TA=25°C unless otherwise specified)**

Parameter	Symbol	Min	Typ	Max	Unit	Test Condition
Reverse Working Voltage	VRWM			3.3	V	
Breakdown Voltage	VBR	3.5			V	IT = 1mA
Reverse Leakage Current	IR			0.2	µA	VRWM = 3.3V
Clamping Voltage	VC			7	V	I <sub>PP</sub> = 1A (8 x 20µs pulse)
Clamping Voltage	VC			10	V	I <sub>PP</sub> = 15A (8 x 20µs pulse)
Junction Capacitance	CJ		20		pF	VR = 0V, f = 1MHz

**Typical Performance Characteristics (TA=25°C unless otherwise Specified)**

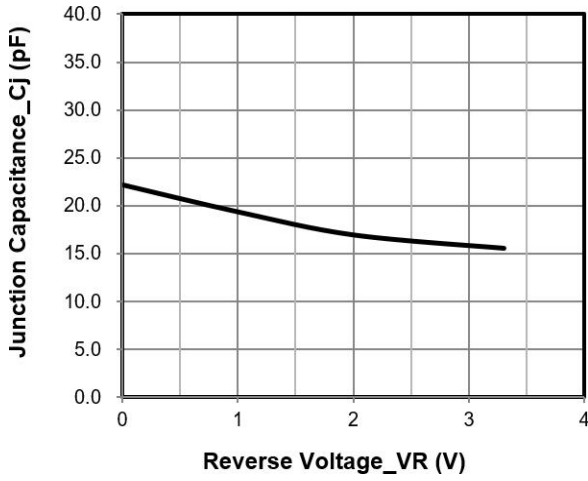

**Junction Capacitance vs. Reverse Voltage**

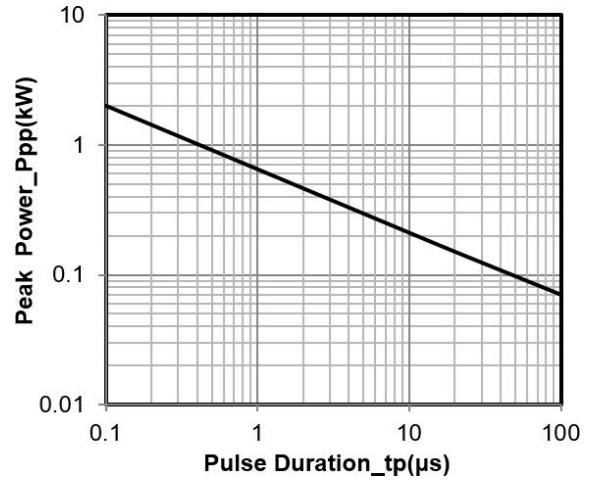

**Peak Pulse Power vs. Pulse Time**

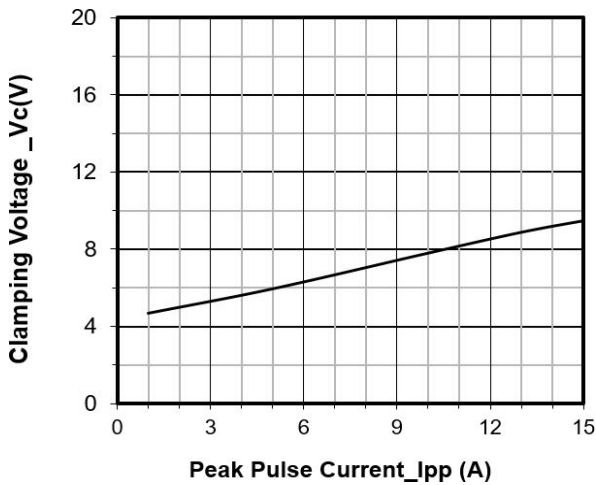

**Clamping Voltage vs. Peak Pulse Current**

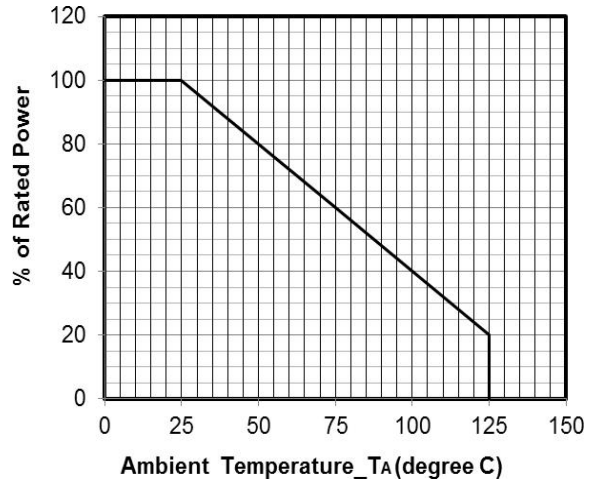

**Power Derating Curve**

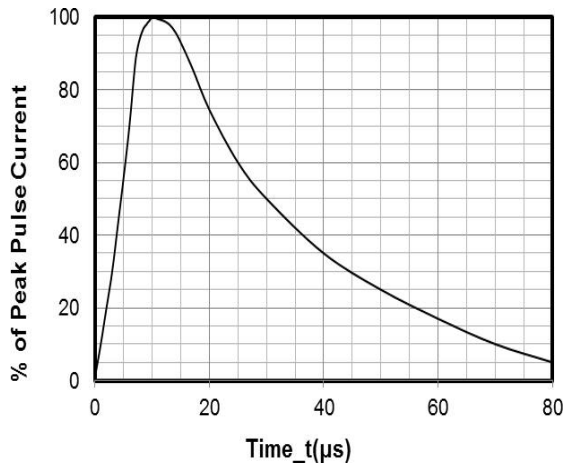

**8 X 20μs Pulse Waveform**

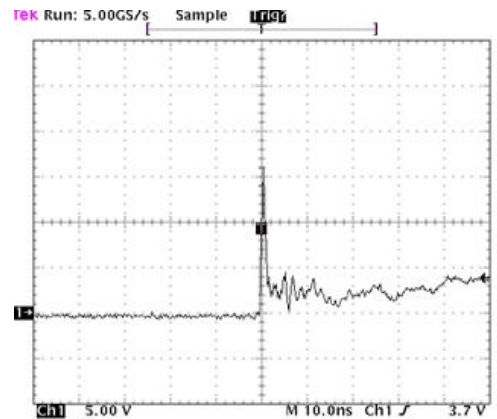

**Note: Data is taken with a 10x attenuator**

**ESD Clamping Voltage**

**8 kV Contact per IEC61000-4-2**

**SOD-523 Package Outline Drawing**

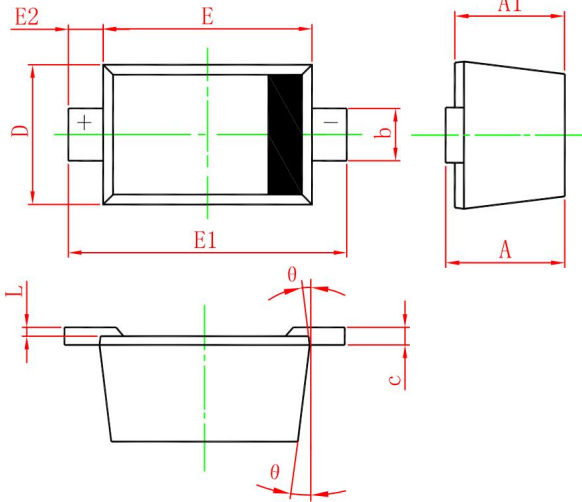

SYM	DIMENSIONS					
	MILLIMETERS			INCHES		
	MIN	NOM	MAX	MIN	NOM	MAX
A	0.51	--	0.77	0.020	--	0.031
A1	0.50	--	0.70	0.020	--	0.028
b	0.25	--	0.35	0.010	--	0.014
c	0.08	--	0.15	0.003	--	0.006
D	0.75	--	0.85	0.030	--	0.033
E	1.10	--	1.30	0.043	--	0.051
E1	1.50	--	1.70	0.059		0.067
E2	0.20REF			0.008REF		
L	0.01	--	0.07	0.001	--	0.003
Θ	7°REF			7°REF		

**Suggested Land Pattern**

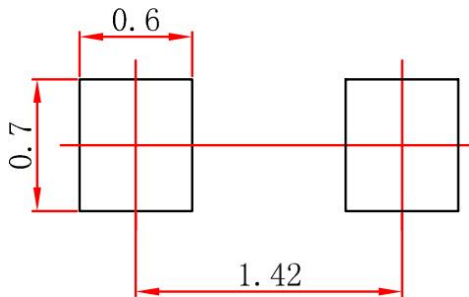

单位 (mm)