

Description

The Rclamp0504P is a low capacitance TVS array, utilizing leading monolithic silicon technology to provide fast response time and low ESD clamping voltage, making this device an ideal solution for protecting voltage sensitive high-speed data lines. The Rclamp0504P complies with the IEC61000-4-2 (ESD) standard with $\pm 30\text{kV}$ air and $\pm 25\text{kV}$ contact discharge. It is assembled into a 6-pin DFN1616-6 lead-free package. Each device will protect up to four high-speed lines. The combination of small size, low capacitance and high surge capability makes them ideal for use in applications such as cellular phones, LCD displays, USB, and multimedia card interfaces.

Mechanical Characteristics

- ◆ Package: DFN1616-6
- ◆ Case Material: "Green" Molding Compound.
- ◆ Moisture Sensitivity: Level 3 per J-STD-020
- ◆ Terminal Connections: See Diagram Below
- ◆ Marking Information: See Below

Dimensions and Pin Configuration

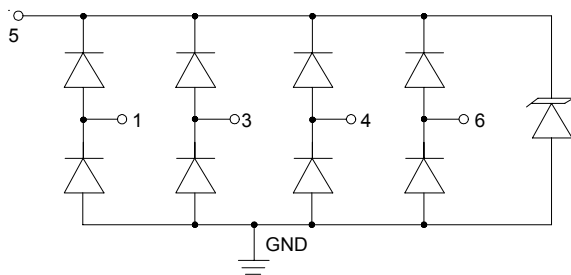

Circuit Diagram

Features

- ◆ Low capacitance: 0.4pF typical(I/O to I/O)
- ◆ Ultra low leakage: nA level
- ◆ Low operating voltage: 5V
- ◆ Low clamping voltage
- ◆ Up to 4 lines and one power line protects
- ◆ Complies with following standards:
 - IEC 61000-4-2 (ESD) immunity test
 - Air discharge: $\pm 30\text{kV}$
 - Contact discharge: $\pm 25\text{kV}$
 - IEC61000-4-5 (Lightning) 5A (8/20 μs)
- ◆ RoHS Compliant

Applications

- ◆ USB 2.0 and USB OTG
- ◆ Multi Media Card Interfaces
- ◆ SD Card Interfaces
- ◆ MDDI Ports
- ◆ SIM Ports
- ◆ Key Pads
- ◆ Gigabit Ethernet

Marking Information

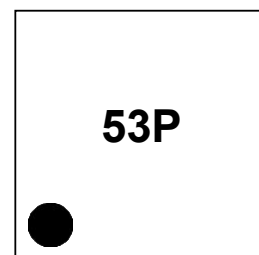

53P = Device Marking Code

Dot denotes Pin1

Ordering Information

Part Number	Marking	Packaging	Reel Size
Rclamp0504P	53P	3000/Tape & Reel	7 inch

Absolute Maximum Ratings ($T_A=25^\circ\text{C}$ unless otherwise specified)

Parameter	Symbol	Value	Unit
Peak Pulse Power (8/20 μs)	Ppk	75	W
Peak Pulse Current (8/20 μs)	I _{PP}	5	A
ESD per IEC 61000-4-2 (Air)	V _{ESD}	± 30	kV
ESD per IEC 61000-4-2 (Contact)		± 25	
Operating Temperature Range	T _J	-55 to +125	$^\circ\text{C}$
Storage Temperature Range	T _{stg}	-55 to +150	$^\circ\text{C}$

Electrical Characteristics ($T_A=25^\circ\text{C}$ unless otherwise specified)

Parameter	Symbol	Min	Typ	Max	Unit	Test Condition
Reverse Working Voltage	V _{RWM}			5	V	Pin 5 to ground
Breakdown Voltage	V _{BR}	6			V	I _T = 1mA, pin 5 to ground
Reverse Leakage Current	I _R			0.5	μA	V _{RWM} = 5V, pin 5 to ground
Clamping Voltage	V _C			10	V	I _{PP} = 1A (8 x 20 μs pulse), any I/O pin to ground
Clamping Voltage	V _C			15	V	I _{PP} = 5A (8 x 20 μs pulse), any I/O pin to ground
Junction Capacitance	C _J			0.4	pF	V _R = 0V, f = 1MHz, between I/O pins
Junction Capacitance	C _J			0.8	pF	V _R = 0V, f = 1MHz, any I/O pin to ground

Typical Performance Characteristics (TA=25°C unless otherwise Specified)

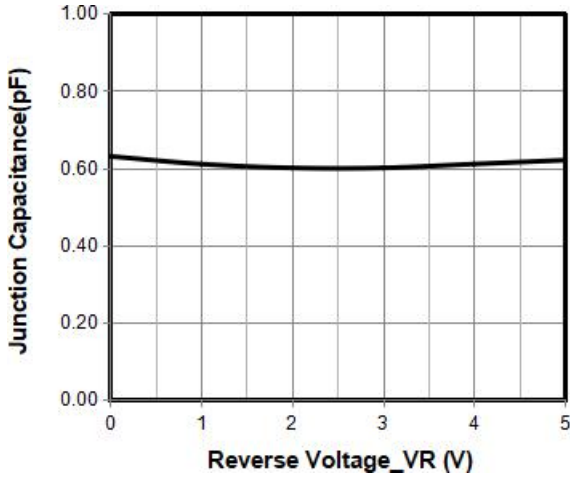

Junction Capacitance vs. Reverse Voltage

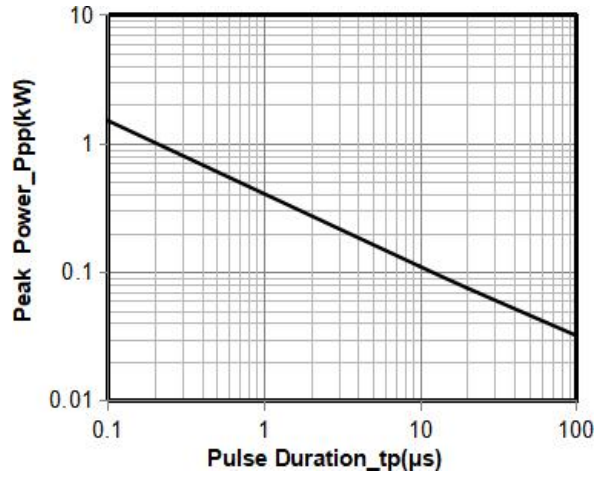

Peak Pulse Power vs. Pulse Time

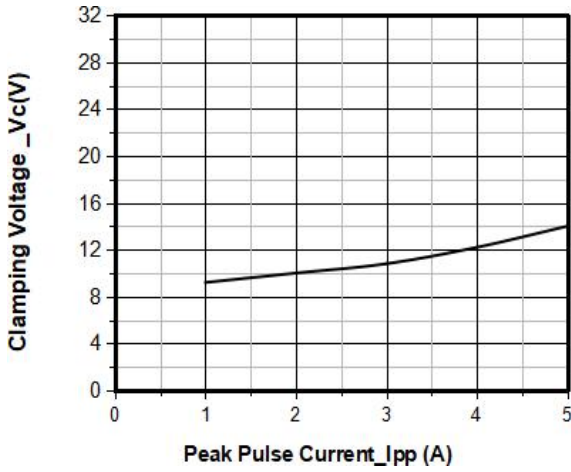

Clamping Voltage vs. Peak Pulse Current

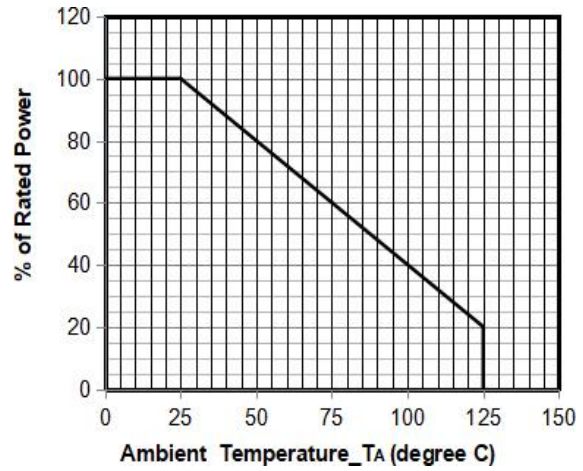

Power Derating Curve

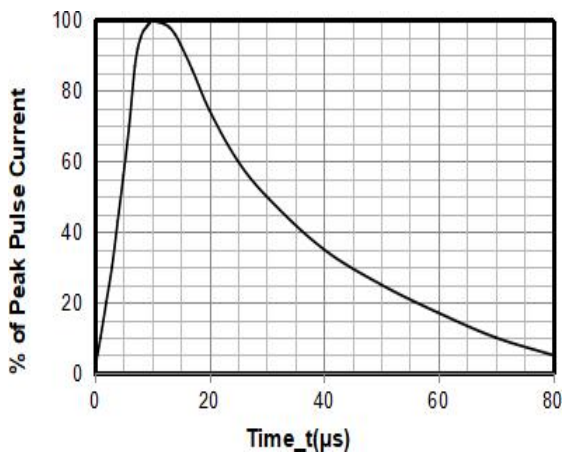

8 X 20μs Pulse Waveform

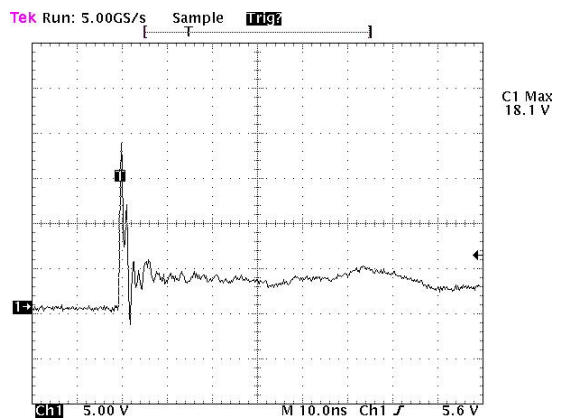

Note: Data is taken with a 10x attenuator

ESD Clamping Voltage

8 kV Contact per IEC61000-4-2

Rclamp0504P on SIM Port Application

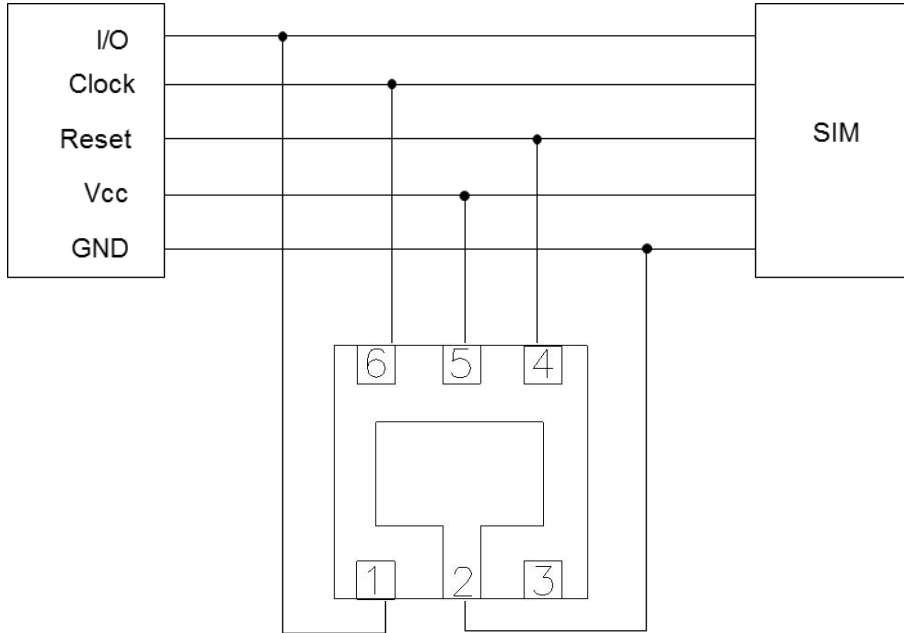

Rclamp0504P on USB OTG Application

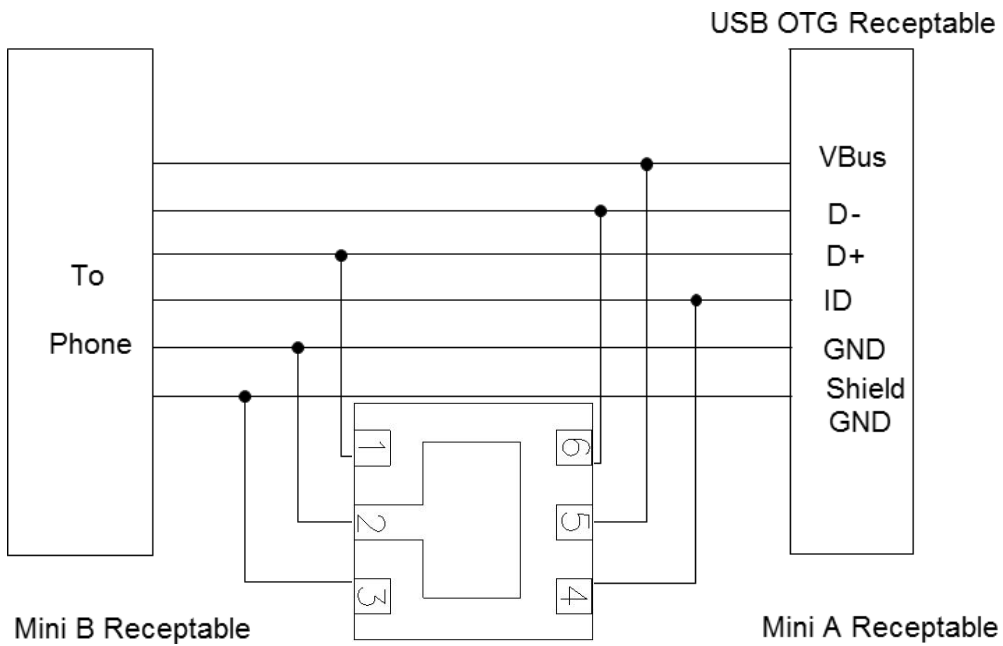

DFN1616-6 Package Outline Drawing

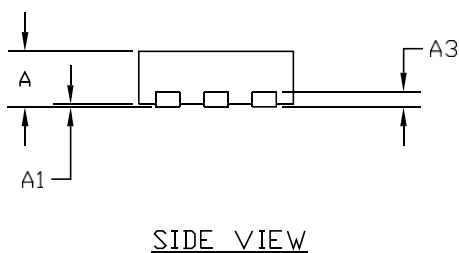
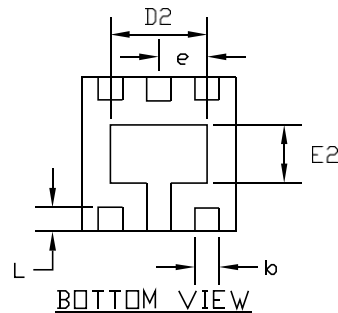
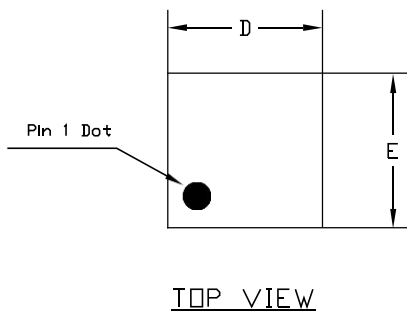

SYM	DIMENSIONS(MM)		
	MIN	NOM	MAX
A	0.50	0.55	0.60
A1	0.00	—	0.05
A3	0.15 REF		
D	1.55	1.60	0.0121.65
E	1.55	1.60	1.65
D2	0.85	1.00	1.10
E2	0.45	0.60	0.70
L	0.20	0.25	0.30
b	0.20	0.25	0.30
e	0.50 BSC		

Suggested Land Pattern

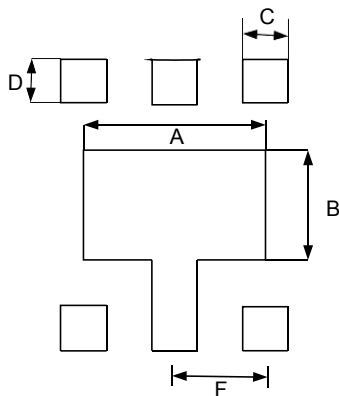

SYM	DIMENSIONS	
	MILLIMETERS	INCHES
A	1.20	0.04
B	0.72	0.028
C	0.30	0.012
D	0.30	0.012
F	0.50	0.020

Contact Information

Changzhou D-first Electronics CO.,Ltd.
 www.first-electronic.com
 Email: yf@first-electronic.cn
 Phone: +86 (0519) 8817 1671