

雅晶鑫電子

Shenzhen Yajingxin Electron Co.,Ltd

Customer	
Production Name	CRYSTAL SEAM 49S
Customer P/N	N/A
P/N	TAXD26.2982M2GLDBET2S
Revision	A
Print Date 合同专用章	2019-5-30

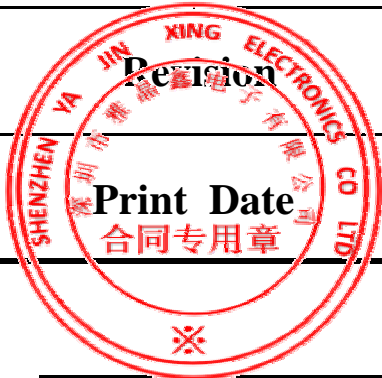

Drawn	Checked	Approved

RoHS Compliant

联络方式：电邮：taesz@163.com 移动：138-0255-9153 联络人：李先生

雅晶鑫電子

Shenzhen Yajingxin Electron Co.,Ltd

ELECTRICAL PARAMETERS

谐振器产品技术指标		Min	Max	Units
1.Holder Type(型号规格)		SEAM 49S		
2.Mode of Oscillation (振动模式)		Fundamental		
3.Frequency (标称频率)		26.298200		MHz
4.Load Capacitance (CL) (负载电容)		20		pF
5.Drive Level (激励功率)		100		uw
6.Equivalent Resistance (谐振电阻)			40	Ω
7.Shunt Capacitance (Co) (静态电容)		0	7	pF
8.Motional Capacitance (C1) (动态电容)		N/A		fF
9.Frequency Tolerance at 25 (调整频差)		-20	20	ppm
10.Stability over operation temperance (温度频差)		± 30		ppm
11.Insulation Resistance (at DC 100V) (绝缘电阻)		500		M Ω
12.Operating Temperature Range (工作温度范围)		-20	70	
13.Storage Temperature Range (储存温度范围)		-40	85	
14.Aging (老化率)		± 5		ppm/year
15.DLD2	N/A		N/A	
16.FLD2			N/A	ppm
17.RLD2			N/A	
18.SPDB	N/A		N/A	db
19.0ther(其它)		N/A		

OUTLINE DIMENSIONS(UNIT:mm) 外形尺寸 (单位: mm)

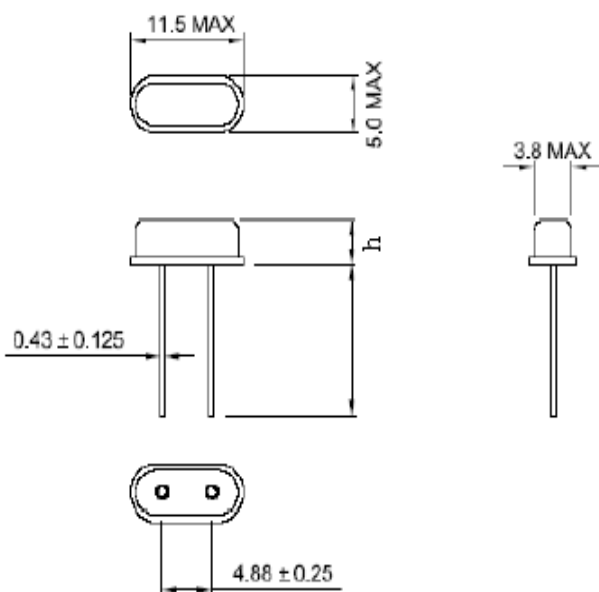

Units:mm

h:	3.3 ± 0.30
H:	13.2 ± 0.5

SUGGESTED REFLOW PROFILE (回流焊曲线图)

Total time:200sec.Max. (总时间:200秒 最大)

Solder melting point:220 (熔点220)

Profiles Feature (特性)		Pb-Free Assembly
Average Ramp-up Rate(Ts max to Tp)平均升温速度		3 /second Max
Preheat	预热	
Temperature Min (Ts min)	最低温度	125
Temperature Max (Ts max)	最高温度	200
Time (ts min to ts max)	从最低到最高时间	(60 ~ 180) seconds
Time maintained above	维持上述时间	
Temperature(T1)	温度	217
Time(tp)	时间	(60 ~ 150) seconds
Peak/Classification Temperature(Tp) 最高点温度		260
Time within 5 of actual Peak Temperature(tp)	高温维持时间	(20 ~ 40) seconds
Ramp-down rate		6 /second max
Time 25 to Peak Temperature		8 minutes max
Suggest reflow times		3 Times max

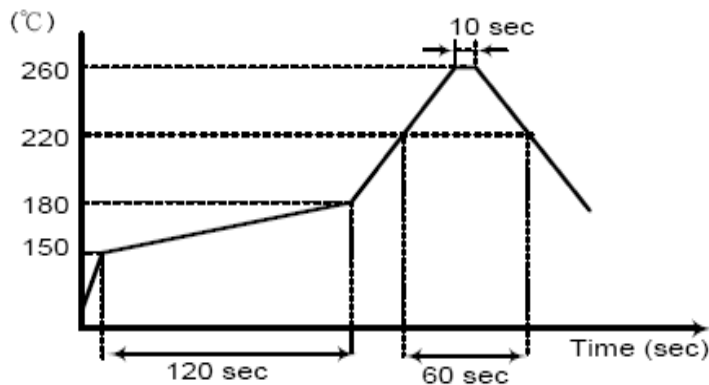

PACKING (包裝)

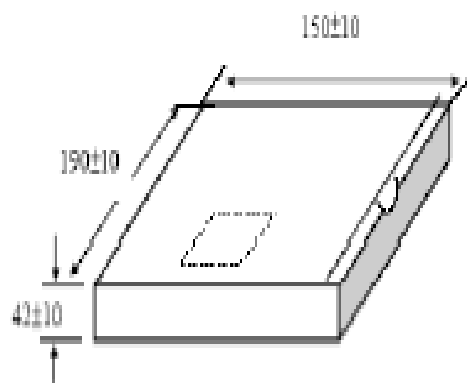
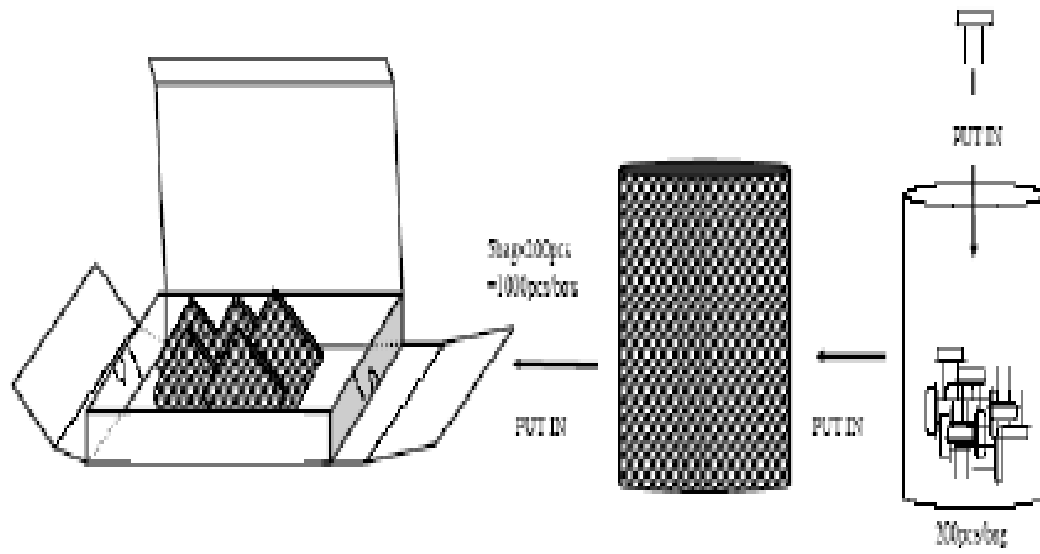

RELIABILITY SPECIFICATIONS (信赖度试验)

No	Test Item (测试项目)	Test Conditions (测试条件)	Reference (参考)
1	High Temperature High Humidity Storage (高温、高湿、储存)	Temperature: 85 ±3 温度: 85 ±3 Relative Humidity:85%RH 相对湿度: 85%RH Time: 96 Hours 时间: 96小时	JIS C5023
2	High Temperature Storage (高温储存)	Temperature: 125 ±3 温度:125 ±3 Time: 96 Hours 时间:96 小时	MIL-STD-883E Method 1005.8
3	Low Temperature Storage (低温储存)	Temperature: -40 ±3 温度 : -40 ±3 Time: 96Hours 时间 : 96小时	MIL-STD-883E Method 1013
4	Thermal Shock (温度冲击)	Temperature1:-55 ±5 温度1:-55 ±5 Temperature2:85 ±5 温度2: 85 ±5 Temperature change between T1 and T2 5 min T1和T2温度在5分钟内改变 10cycles maintain T1 and T2 for 30 minutes each mon 每次循环30分钟共10次	MIL-STD-202F Method 107 Condition A
5	RESISTANCE TO SOLDER HEAT (耐焊接热)	Solder Temperature: 260 ±5 焊槽温度:260 ±5 Time: 10±1 Seconds 时间: 10±1秒	MIL-STD-202F Method 210E
6	Solderability(可焊性)	The solder pot temperature is 245±5 , dwell time 5±0.5s 245 ±5 焊锡槽浸润5 ±0.5秒	J-STD-002B
7	Drop Test (落下试验)	3 Times Free Fall from 75cm height table to 3cm thickness hard wood board 从75cm高度3次跌落到3cm厚硬质木板上	JIS C6701
8	MECHANICAL SHOCK (机械冲击)	Half sine wave,1000 G 半正弦波,加速度1000G 3 Times for all 3 directions X、Y、Z 三个相互垂直方向各三次	MIL-STD-202F Method 213B
9	Vibration (机械振动)	Frequency Range: 10Hz ~ 55Hz 频率范围: 10Hz ~ 55Hz Amplitude: 0.75mm 振幅 : 0.75mm 2 Hours in each direction, total 6 Hours X、Y、Z 三个相互垂直方向各振动2小时	MIL-STD-883E Method 2007.3
10	Leakage Test (气密性)	Take measurements with a helium Leakage detector 氦质检漏 Leakage Rate 1 × 10 ⁻³ Pa cm ³ /s 漏率 1 × 10 ⁻³ Pa cm ³ /s	MIL-STD-883E