

# 具有同步降压控制器、2A LDO 和缓冲基准的 TPS51716 完整 DDR2、DDR3、DDR3L、LPDDR3 和 DDR4 内存电源解决方案

## 1 特性

- 同步降压控制器 (VDDQ)
  - 转换电压范围: 3V 至 28V
  - 输出电压范围: 0.7V 至 1.8V
  - 0.8%  $V_{REF}$  精度
  - D-CAP2™ 针对陶瓷输出电容器的模式
  - 可选 500kHz/670kHz 开关频率
  - 自动跳频功能优化了轻负载和重负载时的效率
  - 支持 S4/S5 状态中的软启动
  - 过流 (OCL) / 过压 (OVP) / 欠压 (UVP) / 欠压闭锁 (UVLO) 保护
  - 电源正常输出
- 2A LDO (VTT)、缓冲基准 (VTTREF)
  - 2A (峰值) 灌电流和拉电流
  - 只需 10 $\mu$ F 陶瓷输出电容器
  - 经缓冲的, 低噪声, 10mA VTTREF 输出
  - 0.8% VTTREF, 20mV VTT 精度
  - 在 S3 中支持高阻抗 (High-Z) 而在 S4/S5 中支持软关闭
- 热关断
- 20 引脚 3mm x 3mm WQFN 封装

## 2 应用

- DDR2、DDR3、DDR3L、LPDDR3 和 DDR4 内存电源
- SSTL\_18、SSTL\_15、SSTL\_135 和 HSTL 终端

## 3 说明

TPS51716 用最少总体成本和最小空间提供一个用于 DDR2、DDR3、DDR3L、LPDDR3 和 DDR4 内存系统的完整电源。它将同步降压稳压器控制器 (VDDQ) 与 2A 灌电流/拉电流跟踪 LDO (VTT) 和缓冲低噪声基准 (VTTREF) 相集成。TPS51716 采用融合了 500kHz 或 670kHz 工作频率的 D-CAP2 模式, 此模式可在无需外部补偿电路的情况下支持陶瓷输出电容器。VTTREF 跟踪 VDDQ/2 的精度高达 0.8%。能够提供 2A 灌电流/拉电流峰值电流功能的 VTT, 而且只需 10 $\mu$ F 的陶瓷电容。此外, 该器件还具有专用 LDO 电源输入。

TPS51716 提供丰富、实用的功能以及出色的电源性能。它支持灵活功率级控制, 将 VTT 置于 S3 中的高阻抗状态并在 S4/S5 状态中将 VDDQ, VTT 和 VTTREF 放电 (软关闭)。它包括具有低侧 MOSFET  $R_{DS}$  (接通) 感测的可编程 OCL, OVP/UVP/UVLO 和热关断保护。

TI 的 TPS51716 采用 20 引脚 3mm x 3mm WQFN 封装, 且其额定环境温度范围介于 -40°C 至 85°C 之间。

### 器件信息(1)

器件型号	封装	封装尺寸 (标称值)
TPS51716	WQFN (20)	3.00mm x 3.00mm

(1) 如需了解所有可用封装, 请参阅数据表末尾的可订购产品附录。

### 框图

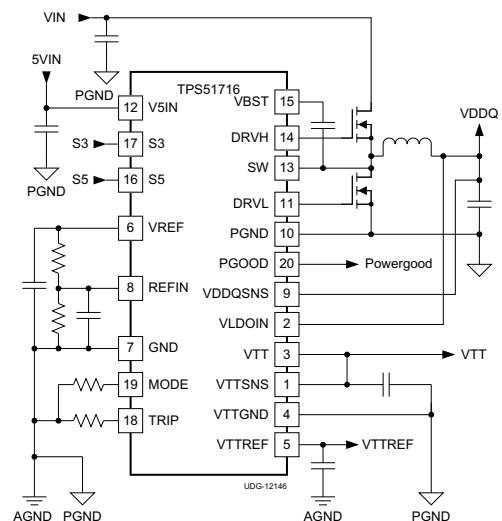

Copyright © 2016, Texas Instruments Incorporated



## 目录

<b>1</b>	特性 .....	<b>1</b>	7.4	Device Functional Modes .....	<b>16</b>
<b>2</b>	应用 .....	<b>1</b>	<b>8</b>	<b>Application and Implementation</b> .....	<b>18</b>
<b>3</b>	说明 .....	<b>1</b>	8.1	Application Information .....	<b>18</b>
<b>4</b>	修订历史记录 .....	<b>2</b>	8.2	Typical Application .....	<b>18</b>
<b>5</b>	<b>Pin Configuration and Functions</b> .....	<b>3</b>	<b>9</b>	<b>Power Supply Recommendations</b> .....	<b>22</b>
<b>6</b>	<b>Specifications</b> .....	<b>4</b>	<b>10</b>	<b>Layout</b> .....	<b>23</b>
6.1	Absolute Maximum Ratings .....	<b>4</b>	10.1	Layout Guidelines .....	<b>23</b>
6.2	ESD Ratings .....	<b>4</b>	10.2	Layout Example .....	<b>24</b>
6.3	Recommended Operating Conditions .....	<b>5</b>	<b>11</b>	器件和文档支持 .....	<b>25</b>
6.4	Thermal Information .....	<b>5</b>	11.1	器件支持 .....	<b>25</b>
6.5	Electrical Characteristics .....	<b>6</b>	11.2	文档支持 .....	<b>25</b>
6.6	Typical Characteristics .....	<b>8</b>	11.3	商标 .....	<b>25</b>
<b>7</b>	<b>Detailed Description</b> .....	<b>12</b>	11.4	静电放电警告 .....	<b>25</b>
7.1	Overview .....	<b>12</b>	11.5	Glossary .....	<b>25</b>
7.2	Functional Block Diagram .....	<b>12</b>	<b>12</b>	机械、封装和可订购信息 .....	<b>25</b>
7.3	Feature Description .....	<b>13</b>			

## 4 修订历史记录

注：之前版本的页码可能与当前版本有所不同。

<b>Changes from Original (October 2012) to Revision A</b>	<b>Page</b>
• 添加了 ESD 额定值表、详细 说明部分，应用和实施部分，电源相关建议部分，布局部分，器件和文档支持部分以及机械、封装和可订购信息部分 .....	<b>1</b>
• 将标题从“完整 DDR2、DDR3、DDR3L 和 LPDDR3 内存电源解决方案”更新为“完整 DDR2、DDR3、DDR3L、LPDDR3 和 DDR4 内存电源解决方案” .....	<b>1</b>
• 在应用 列表中将“DDR2/DDR3/DDR3L/LPDDR3 内存电源”更改为“DDR2、DDR3、DDR3L、LPDDR3 和 DDR4 内存电源” .....	<b>1</b>

## 5 Pin Configuration and Functions

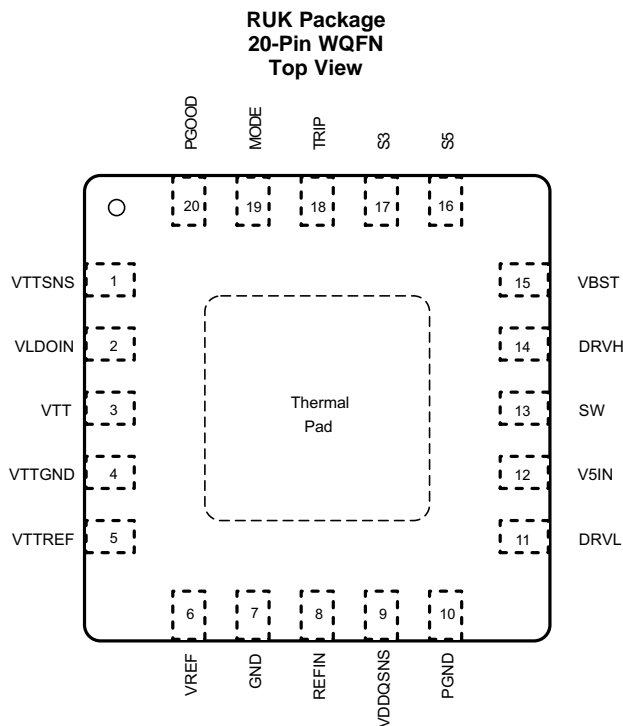

### Pin Functions

PIN		I/O	DESCRIPTION
NAME	NO.		
DRVH	14	O	High-side MOSFET gate driver output.
DRVL	11	O	Low-side MOSFET gate driver output.
GND	7	—	Signal ground.
MODE	19	I	Connect resistor to GND to configure switching frequency, control mode and discharge mode. (See <a href="#">Table 2</a> )
PGND	10	—	Gate driver power ground. $R_{DS(on)}$ current sensing input(+).
PGOOD	20	O	Powergood signal open drain output. PGOOD goes high when VDDQ output voltage is within the target range.
REFIN	8	I	Reference input for VDDQ. Connect to the midpoint of a resistor divider from VREF to GND. Add a capacitor for stable operation.
SW	13	I/O	High-side MOSFET gate driver return. $R_{DS(on)}$ current sensing input(-).
S3	17	I	S3 signal input. (See <a href="#">Table 1</a> )
S5	16	I	S5 signal input. (See <a href="#">Table 1</a> )
TRIP	18	I	Connect resistor to GND to set OCL at $V_{TRIP}/8$ . Output 10- $\mu$ A current at room temperature, $T_C = 4700$ ppm/ $^{\circ}$ C.
VBST	15	I	High-side MOSFET gate driver bootstrap voltage input. Connect a capacitor from the VBST pin to the SW pin.
VDDQSNS	9	I	VDDQ output voltage feedback. Reference input for VTTREF. Also serves as power supply for VTTREF.
VLDOIN	2	I	Power supply input for VTT LDO. Connect VDDQ in typical application.
VREF	6	O	1.8-V reference output
VTT	3	O	VTT 2-A LDO output. Need to connect 10 $\mu$ F or larger capacitance for stability.
VTTGND	4	—	Power ground for VTT LDO
VTTREF	5	O	Buffered VTT reference output. Need to connect 0.22 $\mu$ F or larger capacitance for stability.
VTTSENS	1	I	VTT output voltage feedback.
V5IN	12	I	5-V power supply input for internal circuits and MOSFET gate drivers.
Thermal pad	—	—	Thermal pad. Connect directly to system GND plane with multiple vias.

## 6 Specifications

### 6.1 Absolute Maximum Ratings

 over operating free-air temperature range (unless otherwise noted)<sup>(1)</sup>

		MIN	MAX	UNIT
Input voltage <sup>(2)</sup>	VBST	-0.3	36	V
	VBST <sup>(3)</sup>	-0.3	6	
	SW	-5	30	
	VLDOIN, VDDQSNS, REFIN	-0.3	3.6	
	VTTSENS	-0.3	3.6	
	PGND, VTTGND	-0.3	0.3	
	V5IN, S3, S5, TRIP, MODE	-0.3	6	
Output voltage <sup>(2)</sup>	DRVH	-5	36	V
	DRVH <sup>(3)</sup>	-0.3	6	
	VTTREF, VREF	-0.3	3.6	
	VTT	-0.3	3.6	
	DRVL	-0.3	6	
	PGOOD	-0.3	6	
Junction temperature, T <sub>J</sub>			125	°C
Storage temperature, T <sub>stg</sub>		-55	150	°C

(1) Stresses beyond those listed under *Absolute Maximum Ratings* may cause permanent damage to the device. These are stress ratings only and functional operation of the device at these or any other conditions beyond those indicated under *Recommended Operating Conditions* is not implied. Exposure to absolute-maximum-rated conditions for extended periods may affect device reliability.

(2) All voltage values are with respect to the network ground terminal unless otherwise noted.

(3) Voltage values are with respect to the SW terminal.

### 6.2 ESD Ratings

		VALUE	UNIT
V <sub>(ESD)</sub>	Electrostatic discharge	Human-body model (HBM), per ANSI/ESDA/JEDEC JS-001 <sup>(1)</sup>	±2000
		Charged-device model (CDM), per JEDEC specification JESD22-C101 <sup>(2)</sup>	±500

(1) JEDEC document JEP155 states that 500-V HBM allows safe manufacturing with a standard ESD control process.

(2) JEDEC document JEP157 states that 250-V CDM allows safe manufacturing with a standard ESD control process.

### 6.3 Recommended Operating Conditions

		MIN	NOM	MAX	UNIT
Supply voltage	V5IN	4.5		5.5	V
Input voltage range	VBST	-0.1		33.5	V
	VBST <sup>(1)</sup>	-0.1		5.5	
	SW	-3		28	
	SW <sup>(2)</sup>	-4.5		28	
	VLDOIN, VDDQSNS, REFIN	-0.1		3.5	
	VTTSENS	-0.1		3.5	
	PGND, VTTGND	-0.1		0.1	
	S3, S5, TRIP, MODE	-0.1		5.5	
Output voltage range	DRVH	-3		33.5	V
	DRVH <sup>(1)</sup>	-0.1		5.5	
	DRVH <sup>(2)</sup>	-4.5		33.5	
	VTTREF, VREF	-0.1		3.5	
	VTT	-0.1		3.5	
	DRVL	-0.1		5.5	
	PGOOD	-0.1		5.5	
T <sub>A</sub>	Operating free-air temperature	-40		85	°C

(1) Voltage values are with respect to the SW terminal.

(2) This voltage should be applied for less than 30% of the repetitive period.

### 6.4 Thermal Information

THERMAL METRIC <sup>(1)</sup>		TPS51716	UNIT
		RUK (WQFN)	
		20 PINS	
R <sub>θJA</sub>	Junction-to-ambient thermal resistance	94.1	°C/W
R <sub>θJC(top)</sub>	Junction-to-case (top) thermal resistance	58.1	°C/W
R <sub>θJB</sub>	Junction-to-board thermal resistance	64.3	°C/W
ψ <sub>JT</sub>	Junction-to-top characterization parameter	31.8	°C/W
ψ <sub>JB</sub>	Junction-to-board characterization parameter	58.0	°C/W
R <sub>θJC(bot)</sub>	Junction-to-case (bottom) thermal resistance	5.9	°C/W

(1) For more information about traditional and new thermal metrics, see the [Semiconductor and IC Package Thermal Metrics](#) application report.

### 6.5 Electrical Characteristics

over operating free-air temperature range,  $V_{V5IN} = 5\text{ V}$ , VLDOIN is connected to VDDQ output,  $V_{MODE} = 0\text{ V}$ ,  $V_{S3} = V_{S5} = 5\text{ V}$  (unless otherwise noted)

PARAMETER		TEST CONDITIONS	MIN	TYP	MAX	UNIT
<b>SUPPLY CURRENT</b>						
$I_{V5IN(S0)}$	V5IN supply current, in S0	$T_A = 25^\circ\text{C}$ , No load, $V_{S3} = V_{S5} = 5\text{ V}$		590		$\mu\text{A}$
$I_{V5IN(S3)}$	V5IN supply current, in S3	$T_A = 25^\circ\text{C}$ , No load, $V_{S3} = 0\text{ V}$ , $V_{S5} = 5\text{ V}$		500		$\mu\text{A}$
$I_{V5INSDN}$	V5IN shutdown current	$T_A = 25^\circ\text{C}$ , No load, $V_{S3} = V_{S5} = 0\text{ V}$			1	$\mu\text{A}$
$I_{VLDOIN(S0)}$	VLDOIN supply current, in S0	$T_A = 25^\circ\text{C}$ , No load, $V_{S3} = V_{S5} = 5\text{ V}$			5	$\mu\text{A}$
$I_{VLDOIN(S3)}$	VLDOIN supply current, in S3	$T_A = 25^\circ\text{C}$ , No load, $V_{S3} = 0\text{ V}$ , $V_{S5} = 5\text{ V}$			5	$\mu\text{A}$
$I_{VLDOINSDN}$	VLDOIN shutdown current	$T_A = 25^\circ\text{C}$ , No load, $V_{S3} = V_{S5} = 0\text{ V}$			5	$\mu\text{A}$
<b>VREF OUTPUT</b>						
$V_{VREF}$	Output voltage	$I_{VREF} = 30\text{ }\mu\text{A}$ , $T_A = 25^\circ\text{C}$		1.8000		V
		$0\text{ }\mu\text{A} \leq I_{VREF} < 300\text{ }\mu\text{A}$ , $T_A = -10^\circ\text{C}$ to $85^\circ\text{C}$	1.7856		1.8144	
		$0\text{ }\mu\text{A} \leq I_{VREF} < 300\text{ }\mu\text{A}$ , $T_A = -40^\circ\text{C}$ to $85^\circ\text{C}$	1.7820		1.8180	
$I_{VREFOCL}$	Current limit	$V_{VREF} = 1.7\text{ V}$	0.4	0.8		mA
<b>VTTREF OUTPUT</b>						
$V_{VTTREF}$	Output voltage			$V_{VDDQSNS} / 2$		V
$V_{VTTREF}$	Output voltage tolerance to $V_{VDDQ}$	$ I_{VTTREF}  < 100\text{ }\mu\text{A}$ , $1.2\text{ V} \leq V_{VDDQSNS} \leq 1.8\text{ V}$	49.2%		50.8%	
		$ I_{VTTREF}  < 10\text{ mA}$ , $1.2\text{ V} \leq V_{VDDQSNS} \leq 1.8\text{ V}$	49%		51%	
$I_{VTTREFOCLSRC}$	Source current limit	$V_{VDDQSNS} = 1.8\text{ V}$ , $V_{VTTREF} = 0\text{ V}$	10	18		mA
$I_{VTTREFOCLSNK}$	Sink current limit	$V_{VDDQSNS} = 1.8\text{ V}$ , $V_{VTTREF} = 1.8\text{ V}$	10	17		mA
$I_{VTTREFDIS}$	VTTREF discharge current	$T_A = 25^\circ\text{C}$ , $V_{S3} = V_{S5} = 0\text{ V}$ , $V_{VTTREF} = 0.5\text{ V}$	0.8	1.3		mA
<b>VTT OUTPUT</b>						
$V_{VTT}$	Output voltage			$V_{VTTREF}$		V
$V_{VTTTOL}$	Output voltage tolerance to VTTREF	$ I_{VTT}  \leq 10\text{ mA}$ , $1.2\text{ V} \leq V_{VDDQSNS} \leq 1.8\text{ V}$ , $I_{VTTREF} = 0\text{ A}$	-20		20	mV
		$ I_{VTT}  \leq 1\text{ A}$ , $1.2\text{ V} \leq V_{VDDQSNS} \leq 1.8\text{ V}$ , $I_{VTTREF} = 0\text{ A}$	-30		30	
		$ I_{VTT}  \leq 2\text{ A}$ , $1.4\text{ V} \leq V_{VDDQSNS} \leq 1.8\text{ V}$ , $I_{VTTREF} = 0\text{ A}$	-40		40	
		$ I_{VTT}  \leq 1.5\text{ A}$ , $1.2\text{ V} \leq V_{VDDQSNS} \leq 1.4\text{ V}$ , $I_{VTTREF} = 0\text{ A}$	-40		40	
$I_{VTTOCLSRC}$	Source current limit	$V_{VDDQSNS} = 1.8\text{ V}$ , $V_{VTT} = V_{VTTSENS} = 0.7\text{ V}$ , $I_{VTTREF} = 0\text{ A}$	2	3		A
$I_{VTTOCLSNK}$	Sink current limit	$V_{VDDQSNS} = 1.8\text{ V}$ , $V_{VTT} = V_{VTTSENS} = 1.1\text{ V}$ , $I_{VTTREF} = 0\text{ A}$	2	3		A
$I_{VTTLK}$	Leakage current	$T_A = 25^\circ\text{C}$ , $V_{S3} = 0\text{ V}$ , $V_{S5} = 5\text{ V}$ , $V_{VTT} = V_{VTTREF}$			5	$\mu\text{A}$
$I_{VTTSENSBIAS}$	VTTSENS input bias current	$V_{S3} = 5\text{ V}$ , $V_{S5} = 5\text{ V}$ , $V_{VTTSENS} = V_{VTTREF}$	-0.5	0.0	0.5	$\mu\text{A}$
$I_{VTTSENSLK}$	VTTSENS leakage current	$V_{S3} = 0\text{ V}$ , $V_{S5} = 5\text{ V}$ , $V_{VTTSENS} = V_{VTTREF}$	-1	0	1	$\mu\text{A}$
$I_{VTTDIS}$	VTT Discharge current	$T_A = 25^\circ\text{C}$ , $V_{S3} = V_{S5} = 0\text{ V}$ , $V_{VDDQSNS} = 1.8\text{ V}$ , $V_{VTT} = 0.5\text{ V}$ , $I_{VTTREF} = 0\text{ A}$		7.8		mA
<b>VDDQ OUTPUT</b>						
$V_{VDDQSNS}$	VDDQ sense voltage			$V_{REFIN}$		
$I_{VDDQSNS}$	VDDQSNS input current	$V_{VDDQSNS} = 1.8\text{ V}$		39		$\mu\text{A}$
$I_{REFIN}$	REFIN input current	$V_{REFIN} = 1.8\text{ V}$	-0.1	0.0	0.1	$\mu\text{A}$
$I_{VDDQDIS}$	VDDQ discharge current	$V_{S3} = V_{S5} = 0\text{ V}$ , $V_{VDDQSNS} = 0.5\text{ V}$ , non-tracking discharge mode		12		mA
$I_{VLDOINDIS}$	VLDOIN discharge current	$V_{S3} = V_{S5} = 0\text{ V}$ , $V_{VDDQSNS} = 0.5\text{ V}$ , tracking discharge mode		1.2		A
<b>SWITCH MODE POWER SUPPLY (SMPS) FREQUENCY</b>						
$f_{SW}$	VDDQ switching frequency	$V_{IN} = 12\text{ V}$ , $V_{VDDQSNS} = 1.8\text{ V}$ , $R_{MODE} = 1\text{ k}\Omega$		500		kHz
		$V_{IN} = 12\text{ V}$ , $V_{VDDQSNS} = 1.8\text{ V}$ , $R_{MODE} = 12\text{ k}\Omega$		670		
$t_{ON(min)}$	Minimum on time	DRVH rising to falling <sup>(1)</sup>		60		ns
$t_{OFF(min)}$	Minimum off time	DRVH falling to rising	200	320	450	ns
<b>VDDQ MOSFET DRIVER</b>						
$R_{DRVH}$	DRVH resistance	Source, $I_{DRVH} = -50\text{ mA}$		1.6	3	$\Omega$
		Sink, $I_{DRVH} = 50\text{ mA}$		0.6	1.5	
$R_{DRVL}$	DRVL resistance	Source, $I_{DRVL} = -50\text{ mA}$		0.9	2	$\Omega$
		Sink, $I_{DRVL} = 50\text{ mA}$		0.5	1.2	

(1) Specified by design. Not production tested.

## Electrical Characteristics (continued)

over operating free-air temperature range,  $V_{V5IN} = 5\text{ V}$ , VLDOIN is connected to VDDQ output,  $V_{MODE} = 0\text{ V}$ ,  $V_{S3} = V_{S5} = 5\text{ V}$  (unless otherwise noted)

PARAMETER	TEST CONDITIONS	MIN	TYP	MAX	UNIT	
$t_{DEAD}$	Dead time	DRVH-off to DRVL-on	10		ns	
		DRVL-off to DRVH-on	20			
<b>INTERNAL BOOT STRAP SW</b>						
$V_{FBST}$	Forward voltage	$V_{V5IN-VBST}$ , $T_A = 25^\circ\text{C}$ , $I_F = 10\text{ mA}$	0.1	0.2	V	
$I_{VBSTLK}$	VBST leakage current	$T_A = 25^\circ\text{C}$ , $V_{VBST} = 33\text{ V}$ , $V_{SW} = 28\text{ V}$	0.01	1.5	$\mu\text{A}$	
<b>LOGIC THRESHOLD</b>						
$I_{MODE}$	MODE source current		14	15	16	$\mu\text{A}$
$V_{THMODE}$	MODE threshold voltage	MODE 0-1	109	129	149	mV
		MODE 1-2	235	255	275	
		MODE 2-3	392	412	432	
$V_{IL}$	S3/S5 low-level voltage			0.5	V	
$V_{IH}$	S3/S5 high-level voltage		1.8		V	
$V_{IHYST}$	S3/S5 hysteresis voltage		0.25		V	
$I_{ILK}$	S3/S5 input leak current		-1	0	1	$\mu\text{A}$
<b>SOFT START</b>						
$t_{SS}$	VDDQ soft-start time	Internal soft-start time, $C_{VREF} = 0.1\ \mu\text{F}$ , S5 rising to $V_{VDDOSNS} > 0.99 \times V_{REFIN}$		1.1		ms
<b>PGOOD COMPARATOR</b>						
$V_{THPG}$	VDDQ PGOOD threshold	PGOOD in from higher	106%	108%	110%	
		PGOOD in from lower	90%	92%	94%	
		PGOOD out to higher	114%	116%	118%	
		PGOOD out to lower	82%	84%	86%	
$I_{PG}$	PGOOD sink current	$V_{PGOOD} = 0.5\text{ V}$	3	5.9		mA
$t_{PGDLY}$	PGOOD delay time	Delay for PGOOD in	0.8	1	1.2	ms
		Delay for PGOOD out, with 100 mV over drive		330		ns
$t_{PGSSDLY}$	PGOOD start-up delay	$C_{VREF} = 0.1\ \mu\text{F}$ , S5 rising to PGOOD rising		2.5		ms
<b>PROTECTIONS</b>						
$I_{TRIP}$	TRIP source current	$T_A = 25^\circ\text{C}$ , $V_{TRIP} = 0.4\text{ V}$	9	10	11	$\mu\text{A}$
$TC_{ITRIP}$	TRIP source current temperature coefficient <sup>(1)</sup>			4700		ppm/ $^\circ\text{C}$
$V_{TRIP}$	$V_{TRIP}$ voltage range		0.2		3	V
$V_{OCL}$	Current limit threshold	$V_{TRIP} = 3.0\text{ V}$	360	375	390	mV
		$V_{TRIP} = 1.6\text{ V}$	190	200	210	
		$V_{TRIP} = 0.2\text{ V}$	20	25	30	
$V_{OCLN}$	Negative current limit threshold	$V_{TRIP} = 3.0\text{ V}$	-390	-375	-360	mV
		$V_{TRIP} = 1.6\text{ V}$	-210	-200	-190	
		$V_{TRIP} = 0.2\text{ V}$	-30	-25	-20	
$V_{ZC}$	Zero cross detection offset			0		mV
$V_{UVLO}$	V5IN UVLO threshold voltage	Wake-up	4.2	4.4	4.5	V
		Shutdown	3.7	3.9	4.1	
$V_{OVP}$	VDDQ OVP threshold voltage	OVP detect voltage	118%	120%	122%	
$t_{OVDPDY}$	VDDQ OVP propagation delay	With 100 mV over drive		430		ns
$V_{UVP}$	VDDQ UVP threshold voltage	UVP detect voltage	66%	68%	70%	
$t_{UVDPDY}$	VDDQ UVP delay			1		ms
$t_{UVPENDLY}$	VDDQ UVP enable delay			1.2		ms
$V_{OOB}$	OOB Threshold voltage			108%		
<b>THERMAL SHUTDOWN</b>						
$T_{SDN}$	Thermal shutdown threshold	Shutdown temperature <sup>(1)</sup>		140		$^\circ\text{C}$
		Hysteresis <sup>(1)</sup>		10		

### 6.6 Typical Characteristics

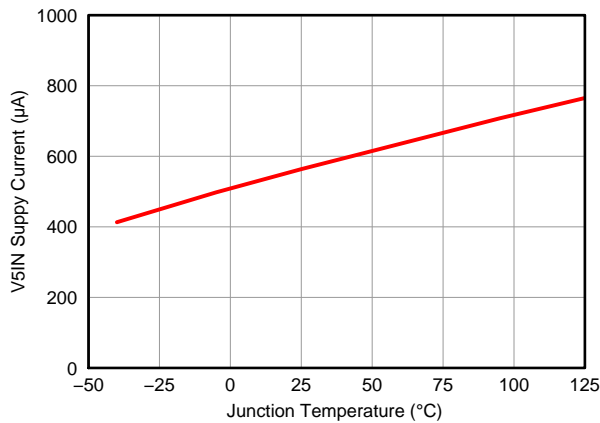

Figure 1. V5IN Supply Current vs Junction Temperature

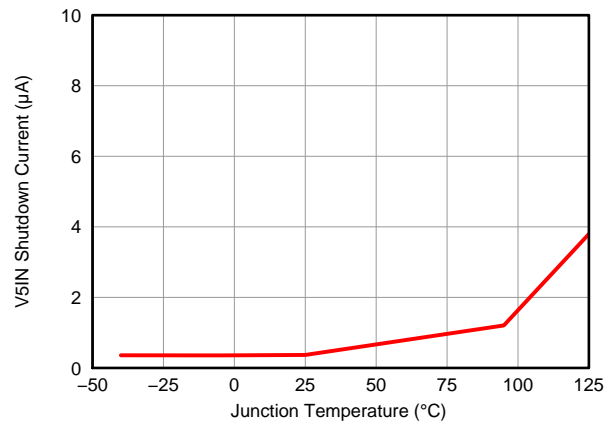

Figure 2. V5IN Shutdown Current vs Junction Temperature

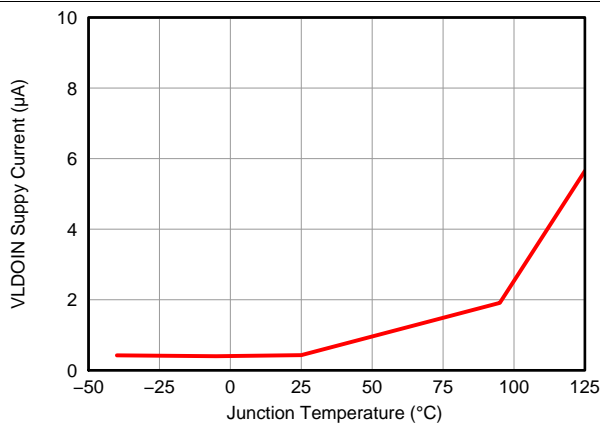

Figure 3. VLDOIN Supply Current vs Junction Temperature

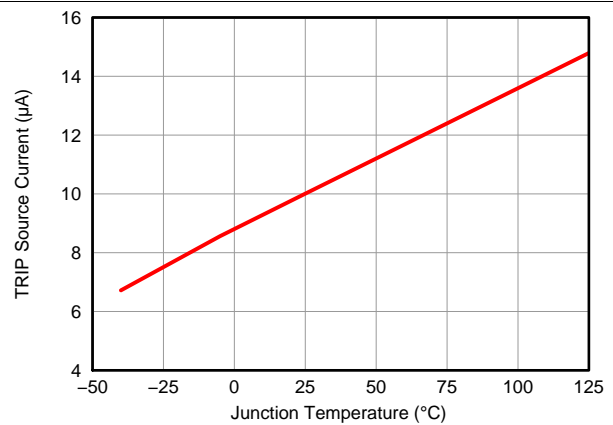

Figure 4. Current Sense Current vs Junction Temperature

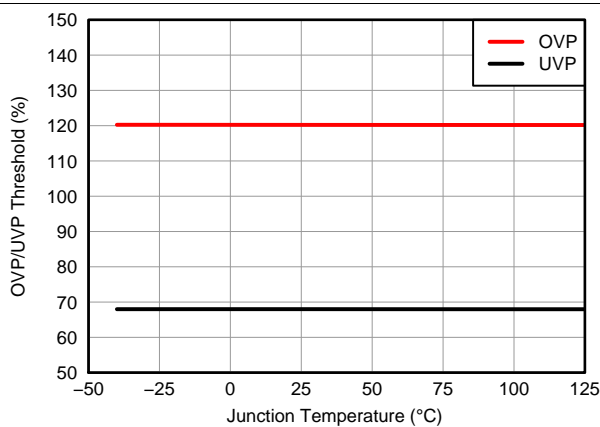

Figure 5. OVP/UVP Threshold vs Junction Temperature

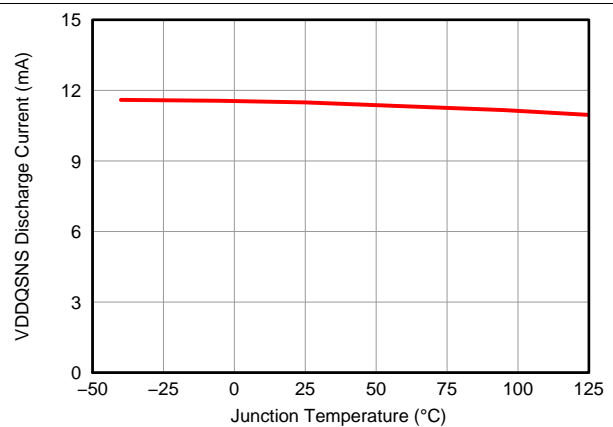

Figure 6. VDDQSNS Discharge Current vs Junction Temperature



Typical Characteristics (continued)

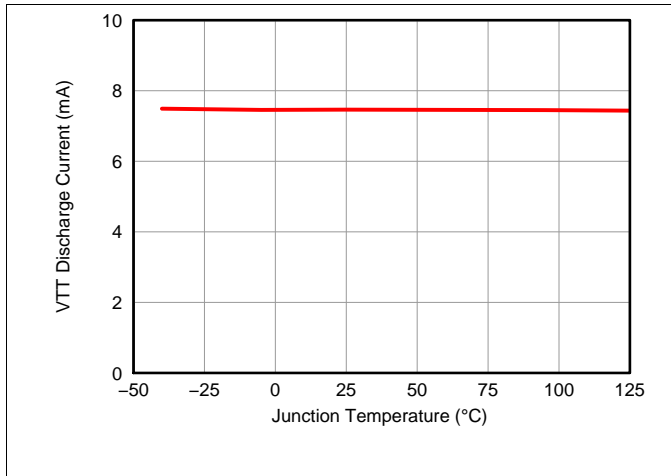

Figure 7. VTT Discharge Current vs Junction Temperature

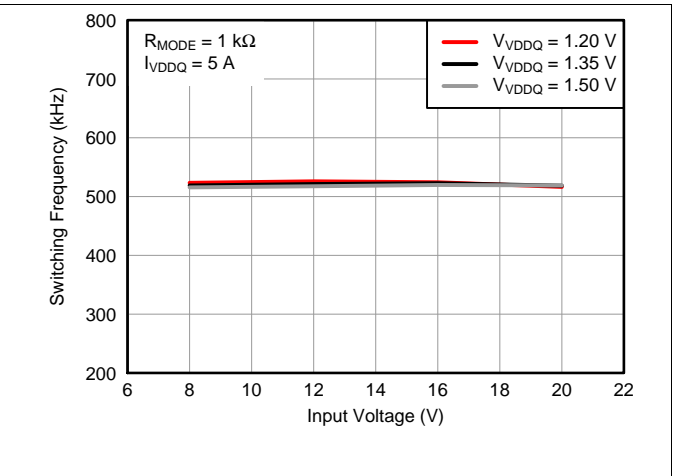

Figure 8. Switching Frequency vs Input Voltage

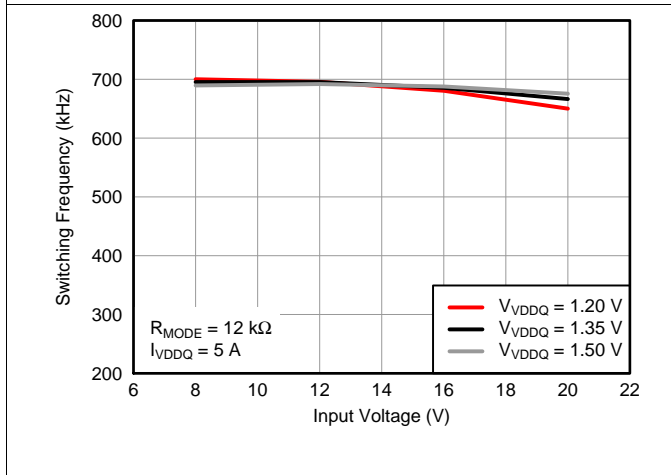

Figure 9. Switching Frequency vs Input Voltage

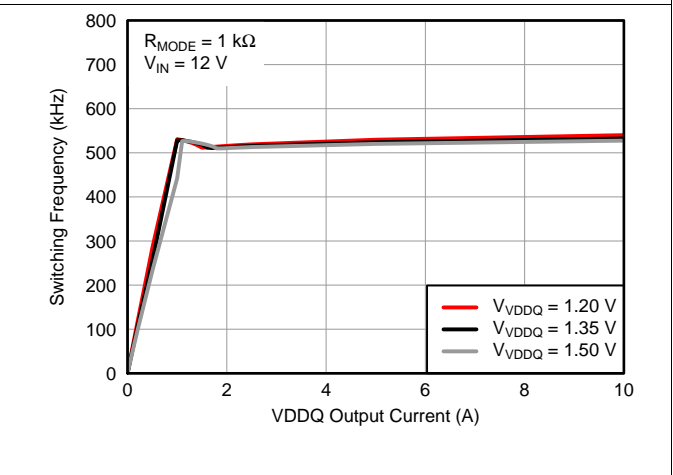

Figure 10. Switching Frequency vs Load Current

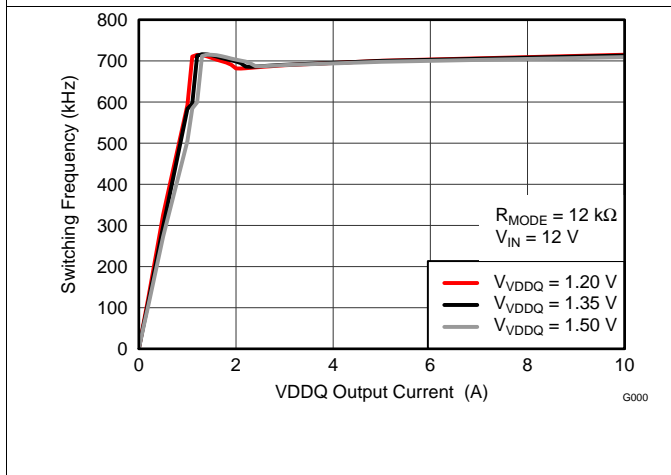

Figure 11. Switching Frequency vs Load Current

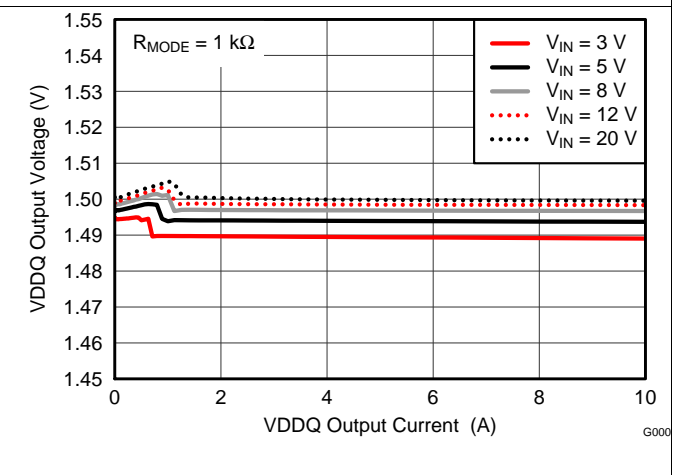

Figure 12. Load Regulation

Typical Characteristics (continued)

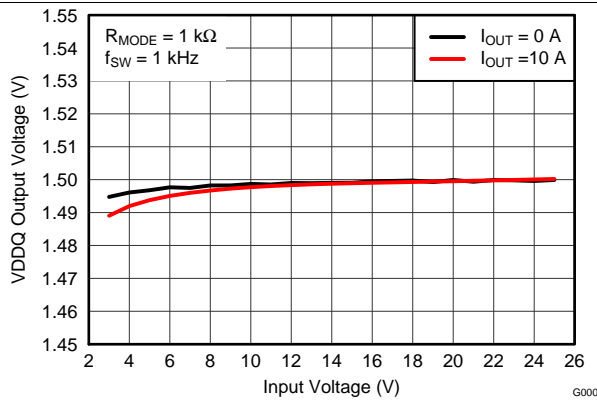

Figure 13. Line Regulation

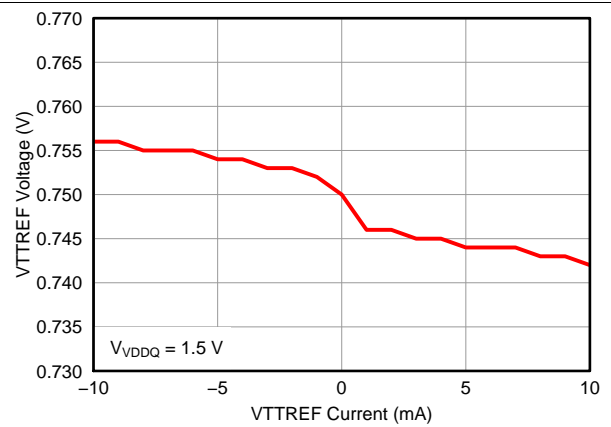

Figure 14. VTTREF Load Regulation

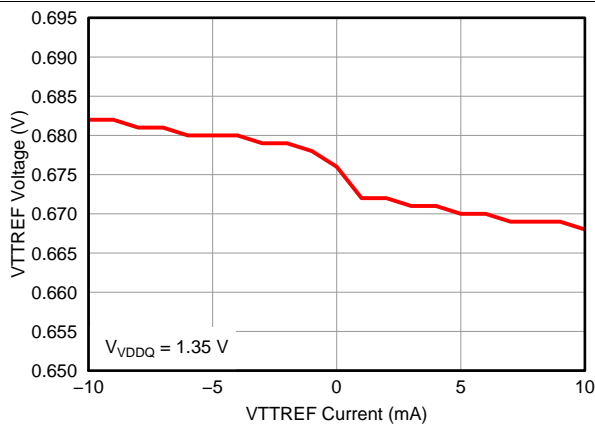

Figure 15. VTTREF Load Regulation

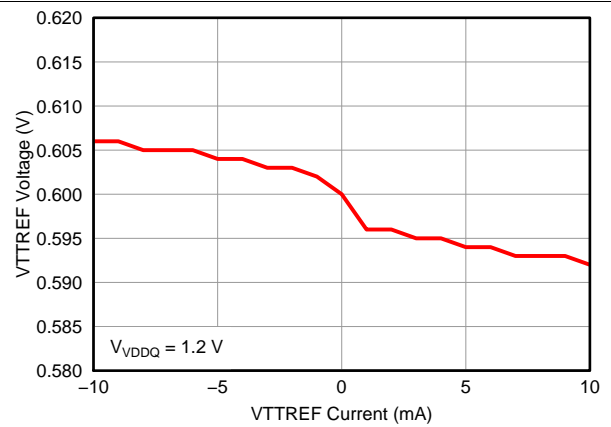

Figure 16. VTTREF Load Regulation

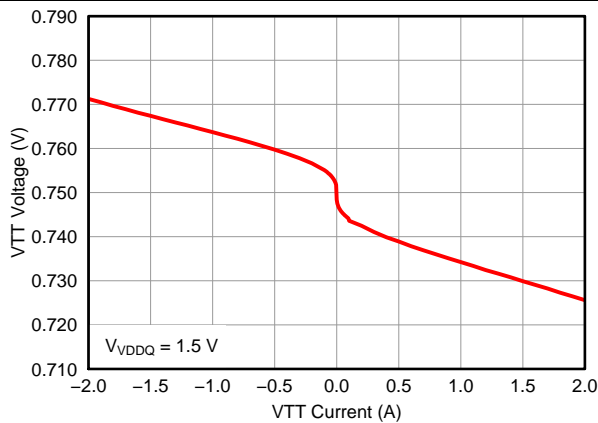

Figure 17. VTT Load Regulation

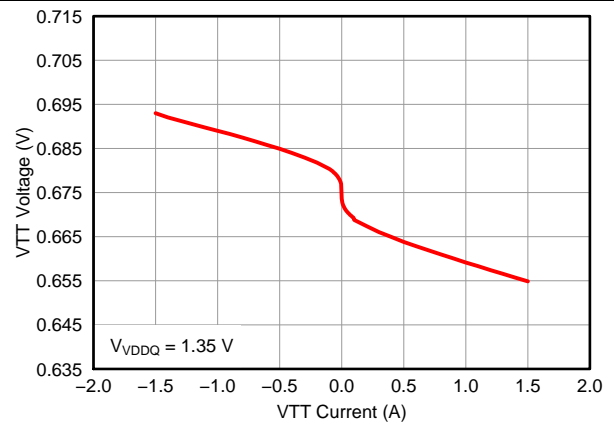

Figure 18. VTT Load Regulation

Typical Characteristics (continued)

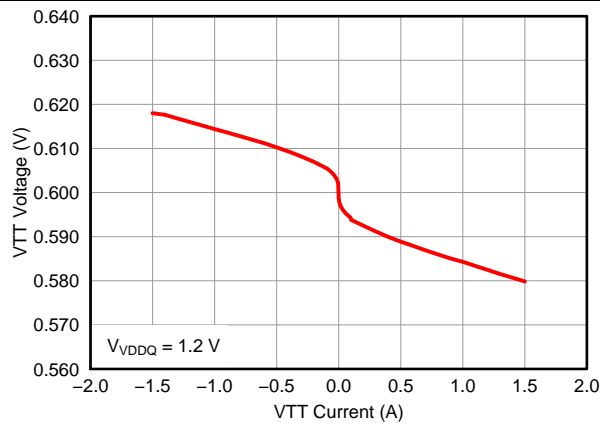

Figure 19. VTT Load Regulation

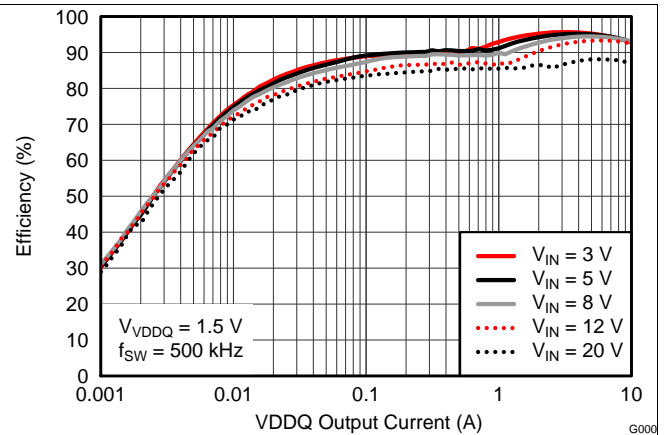

Figure 20. Efficiency

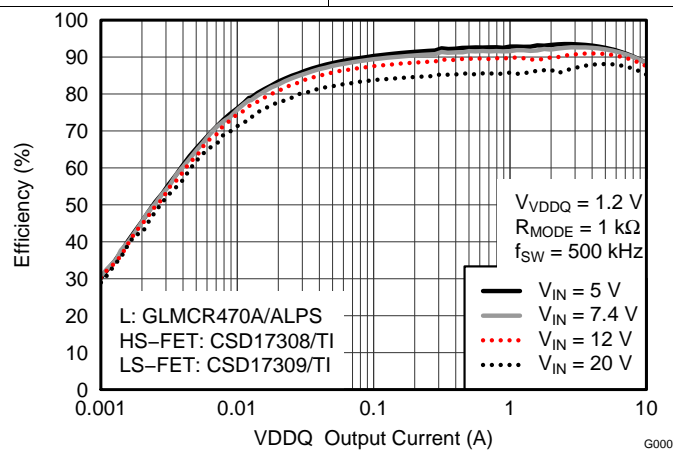

Figure 21. Efficiency

## 7 Detailed Description

### 7.1 Overview

The TPS51716 provides a complete power supply for DDR2, DDR3, DDR3L, LPDDR3, and DDR4 memory systems in the lowest total cost and minimum space. It integrates a synchronous buck regulator controller (VDDQ) with a 2-A sink/source tracking LDO (VTT) and buffered low noise reference (VTTREF). The TPS51716 employs D-CAP2 mode coupled with 500 kHz or 670 kHz operating frequencies that supports ceramic output capacitors without an external compensation circuit. The VTTREF tracks VDDQ/2 with excellent 0.8% accuracy. The VTT, which provides 2-A sink/source peak current capabilities, requires only 10- $\mu$ F of ceramic capacitance. In addition, the device features a dedicated LDO supply input.

### 7.2 Functional Block Diagram

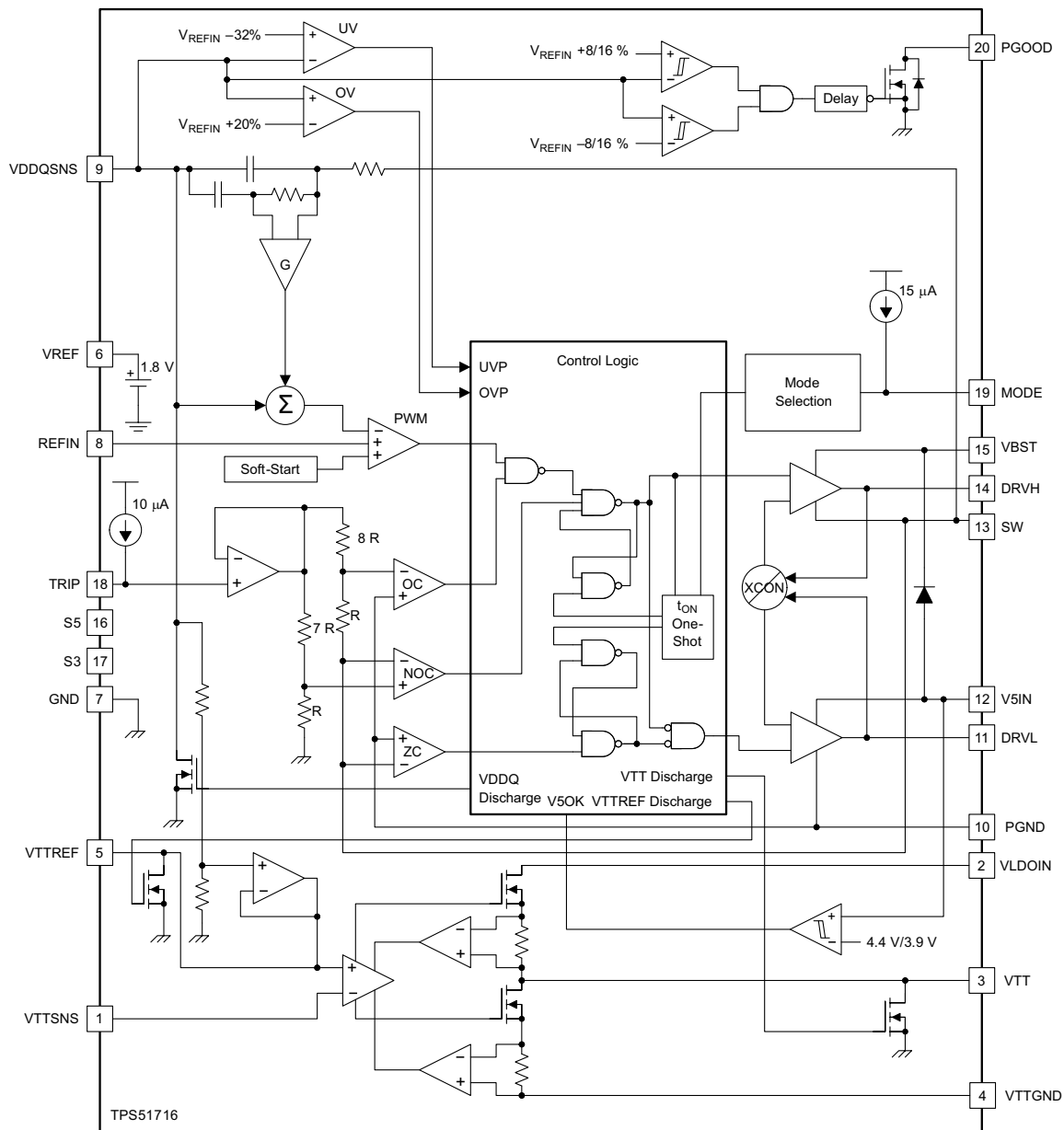
 UDG-12151  
 Copyright © 2016, Texas Instruments Incorporated

### 7.3 Feature Description

#### 7.3.1 VDDQ Switch Mode Power Supply Control

The TPS51716 supports D-CAP2 mode, which does not require complex external compensation networks and are suitable for designs with small external components counts. The D-CAP2 mode is dedicated for a configuration with very low ESR output capacitors such as multi-layer ceramic capacitors (MLCC). An adaptive on-time control scheme is used to achieve pseudo-constant frequency. The TPS51716 adjusts the on-time ( $t_{ON}$ ) to be inversely proportional to the input voltage ( $V_{IN}$ ) and proportional to the output voltage ( $V_{VDDQ}$ ). This produces a switching frequency that is approximately constant over the variation of input voltage at the steady state condition.

#### 7.3.2 VREF and REFIN, VDDQ Output Voltage

The part provides a 1.8-V,  $\pm 0.8\%$  accurate, voltage reference from VREF. This output has a 300- $\mu$ A (max) current capability to drive the REFIN input voltage through a voltage divider circuit. A capacitor with a value of 0.1- $\mu$ F or larger should be attached close to the VREF terminal.

The VDDQ switch-mode power supply (SMPS) output voltage is defined by REFIN voltage, within the range between 0.7 V and 1.8 V, programmed by the resistor-divider connected between VREF and GND. (See [External Components Selection](#) section.) A few nano farads of capacitance from REFIN to GND is recommended for stable operation.

#### 7.3.3 Soft-Start and Powergood

Provide a voltage supply to VIN and V5IN before asserting S5 to high. TPS51716 provides integrated VDDQ soft-start functions to suppress in-rush current at start-up. The soft-start is achieved by controlling internal reference voltage ramping up. [Figure 22](#) shows the start-up waveforms. The switching regulator waits for 400 $\mu$ s after S5 assertion. The MODE pin voltage is read in this period. A typical VDDQ ramp up duration is 700 $\mu$ s.

TPS51716 has a powergood open-drain output that indicates the VDDQ voltage is within the target range. The target voltage window and transition delay times of the PGOOD comparator are  $\pm 8\%$  (typ) and 1-ms delay for assertion (low to high), and  $\pm 16\%$  (typ) and 330-ns delay for de-assertion (high to low) during running. The PGOOD start-up delay is 2.5 ms after S5 is asserted to high. Note that the time constant which is composed of the REFIN capacitor and a resistor divider needs to be short enough to reach the target value before PGOOD comparator enabled.

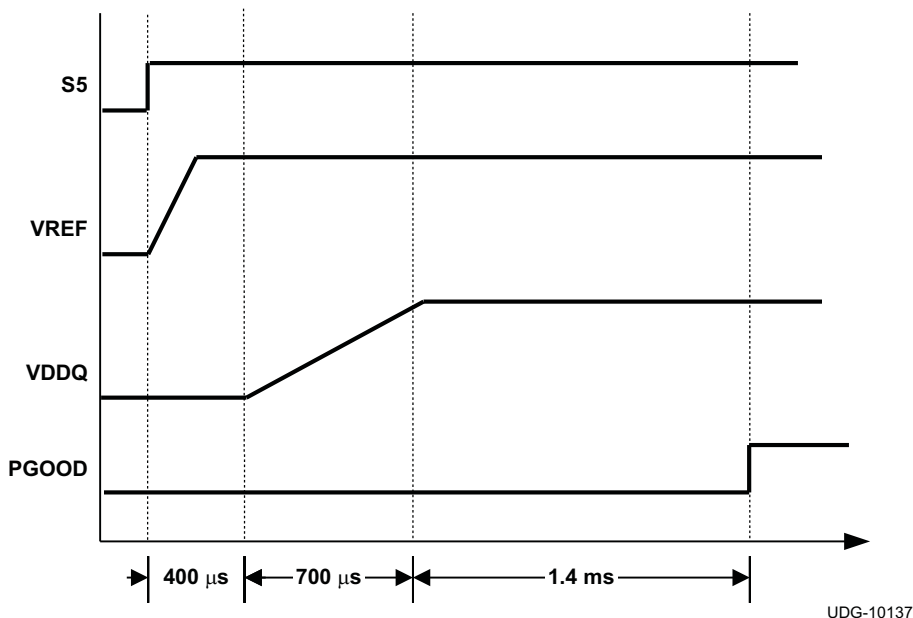

Figure 22. Typical Start-Up Waveforms

## Feature Description (continued)

### 7.3.4 Power State Control

The TPS51716 has two input pins, S3 and S5, to provide simple control scheme of power state. All of VDDQ, VTTREF and VTT are turned on at S0 state (S3=S5=high). In S3 state (S3=low, S5=high), VDDQ and VTTREF voltages are kept on while VTT is turned off and left at high impedance state (high-Z). The VTT output floats and does not sink or source current in this state. In S4/S5 states (S3=S5=low), all of the three outputs are turned off and discharged to GND according to the discharge mode selected by MODE pin. Each state code represents as follow; S0 = full ON, S3 = suspend to RAM (STR), S4 = suspend to disk (STD), S5 = soft OFF. (See [Table 1](#).)

**Table 1. S3/S5 Power State Control**

STATE	S3	S5	VREF	VDDQ	VTTREF	VTT
S0	HI	HI	ON	ON	ON	ON
S3	LO	HI	ON	ON	ON	OFF (High-Z)
S4/S5	LO	LO	OFF	OFF (Discharge)	OFF (Discharge)	OFF (Discharge)

### 7.3.5 VDDQ Overvoltage and Undervoltage Protection

The TPS51716 sets the overvoltage protection (OVP) when VDDQSNS voltage reaches a level 20% (typ) higher than the REFIN voltage. When an OV event is detected, the controller changes the output target voltage to 0 V. This usually turns off DRVH and forces DRVL to be on. When the inductor current begins to flow through the low-side MOSFET and reaches the negative OCL, DRVL is turned off and DRVH is turned on, for a minimum on-time.

After the minimum on-time expires, DRVH is turned off and DRVL is turned on again. This action minimizes the output node undershoot due to LC resonance. When the VDDQSNS reaches 0 V, the driver output is latched as DRVH off, DRVL on. VTTREF and VTT are turned off and discharged using the non-tracking discharge MOSFETs regardless of the tracking mode.

The undervoltage protection (UVP) latch is set when the VDDQSNS voltage remains lower than 68% (typ) of the REFIN voltage for 1 ms or longer. In this fault condition, the controller latches DRVH low and DRVL low and discharges the VDDQ, VTT and VTTREF outputs. UVP detection function is enabled after 1.2 ms of SMPS operation to ensure startup.

To release the OVP and UVP latches, toggle S5 or adjust the V5IN voltage down and up beyond the undervoltage lockout threshold.

### 7.3.6 VDDQ Out-of-Bound Operation

When the output voltage rises to 8% above the target value, the out-of-bound operation starts. During the out-of-bound condition, the controller operates in forced PWM-only mode. Turning on the low-side MOSFET beyond the zero inductor current quickly discharges the output capacitor. During this operation, the cycle-by-cycle negative overcurrent limit is also valid. Once the output voltage returns to within regulation range, the controller resumes to auto-skip mode.

### 7.3.7 VDDQ Overcurrent Protection

The VDDQ SMPS has cycle-by-cycle overcurrent limiting protection. The inductor current is monitored during the off-state using the low-side MOSFET  $R_{DS(on)}$ , and the controller maintains the off-state when the inductor current is larger than the overcurrent trip level. The current monitor circuit inputs are PGND and SW pins so that those should be properly connected to the source and drain terminals of low-side MOSFET. The overcurrent trip level,  $V_{OCTRIP}$ , is determined by [Equation 1](#), where  $R_{TRIP}$  is the value of the resistor connected between the TRIP pin and GND, and  $I_{TRIP}$  is the current sourced from the TRIP pin.  $I_{TRIP}$  is 10  $\mu$ A typically at room temperature, and has 4700ppm/°C temperature coefficient to compensate the temperature dependency of the low-side MOSFET  $R_{DS(on)}$ .

$$V_{OCTRIP} = R_{TRIP} \times \frac{I_{TRIP}}{8} \quad (1)$$

Because the comparison is done during the off-state,  $V_{OCTRIP}$  sets the valley level of the inductor current. The load current OCL level,  $I_{OCL}$ , can be calculated by considering the inductor ripple current as shown in [Equation 2](#).

$$I_{OCL} = \left( \frac{V_{OCTRIP}}{R_{DS(on)}} \right) + \frac{I_{IND(ripple)}}{2} = \left( \frac{V_{OCTRIP}}{R_{DS(on)}} \right) + \frac{1}{2} \times \frac{V_{IN} - V_{OUT}}{L_X} \times \frac{V_{OUT}}{f_{SW} \times V_{IN}}$$

where

- $I_{IND(ripple)}$  is inductor ripple current (2)

In an overcurrent condition, the current to the load exceeds the current to the output capacitor, thus the output voltage tends to fall down. Eventually, it crosses the undervoltage protection threshold and shuts down.

### 7.3.8 VTT and VTTREF

TPS51716 integrates two high performance, low-dropout linear regulators, VTT and VTTREF, to provide complete DDR2, DDR3, DDR3L, LPDDR3, and DDR4 power solutions. The VTTREF has a 10-mA sink/source current capability, and tracks ½ of VDDQSNS with ±1% accuracy using an on-chip ½ divider. A 0.22-µF (or larger) ceramic capacitor must be connected close to the VTTREF terminal to ensure stable operation. The VTT responds quickly to track VTTREF within ±40 mV at all conditions, and the current capability is 2 A for both sink and source. A 10-µF (or larger) ceramic capacitor(s) need to be connected close to the VTT terminal for stable operation. To achieve tight regulation with minimum effect of wiring resistance, a remote sensing terminal, VTTSENS, should be connected to the positive node of VTT output capacitor(s) as a separate trace from the high-current line to the VTT pin. (Refer to the [Layout Guidelines](#) section for details.)

When VTT is not required in the design, the following treatment is strongly recommended.

- Connect VLDOIN to VDDQ.
- Tie VTTSENS to VTT, and remove capacitors from VTT to float.
- Connect VTTGND to GND.
- Select MODE2, 3, 4, or 5 shown in [Table 2](#) (Select Non-tracking discharge mode).
- Maintain a 0.22-µF capacitor connected at VTTREF.
- Pull down S3 to GND with 1-kΩ resistance.

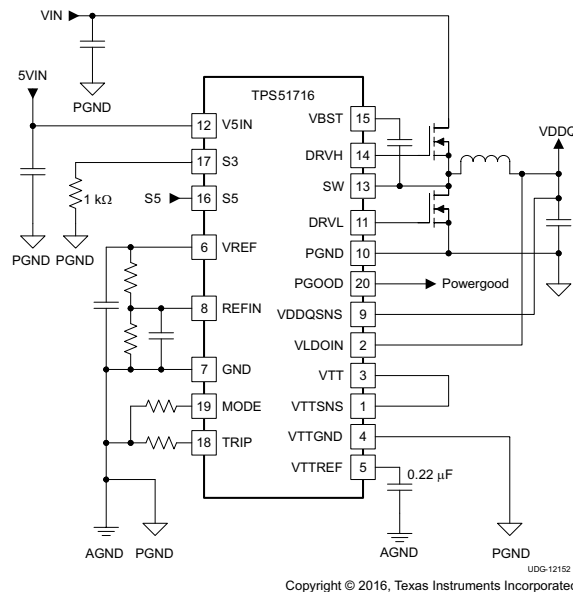

Figure 23. Application Circuit When VTT is not Required

### 7.3.9 VTT Overcurrent Protection

The LDO has an internally fixed constant overcurrent limiting of 3-A (typ) for both sink and source operation.

#### 7.3.10 V5IN Undervoltage Lockout (UVLO) Protection

The TPS51716 has a 5-V supply UVLO protection threshold. When the V5IN voltage is lower than UVLO threshold voltage, typically 3.9 V, VDDQ, VTT, and VTTREF are shut off. This is a non-latch protection.

#### 7.3.11 Thermal Shutdown

The TPS51716 includes an internal temperature monitor. If the temperature exceeds the threshold value, 140°C (typ), VDDQ, VTT, and VTTREF are shut off. The state of VDDQ is open, and that of VTT and VTTREF are high impedance (high-Z) at thermal shutdown. The discharge functions of all outputs are disabled. This is a non-latch protection and the operation is restarted with soft-start sequence when the device temperature is reduced by 10°C (typ).

## 7.4 Device Functional Modes

### 7.4.1 MODE Pin Configuration

The TPS51716 reads the MODE pin voltage when the S5 signal is raised high and stores the status in a register. A 15- $\mu$ A current is sourced from the MODE pin during this time to read the voltage across the resistor connected between the pin and GND. [Table 2](#) shows resistor values, corresponding control mode, switching frequency and discharge mode configurations.

**Table 2. MODE Selection**

MODE NO.	RESISTANCE BETWEEN MODE AND GND (k $\Omega$ )	CONTROL MODE	SWITCHING FREQUENCY (kHz)	DISCHARGE MODE
3	33	D-CAP2	500	Non-Tracking
2	22		670	
1	12		670	Tracking
0	1		500	

### 7.4.2 Discharge Control

In S4/S5 state, VDDQ, VTT, and VTTREF outputs are discharged based on the respective discharge mode selected above. The tracking discharge mode discharges VDDQ output through the internal VTT regulator transistors enabling quick 13 ms discharge operation. The VTT output maintains tracking of the VTTREF voltage in this mode. (Please refer to [Figure 28](#)) After 4 ms of tracking discharge operation, the mode changes to non-tracking discharge. The VDDQ output must be connected to the VLDOIN pin in this mode. The non-tracking mode discharges the VDDQ and VTT pins using internal MOSFETs that are connected to corresponding output terminals. The non-tracking discharge is slow compared with the tracking discharge due to the lower current capability of these MOSFETs. Refer to [Figure 29](#).



### 7.4.3 D-CAP2 Mode Operation

Figure 24 shows simplified model of D-CAP2 architecture.

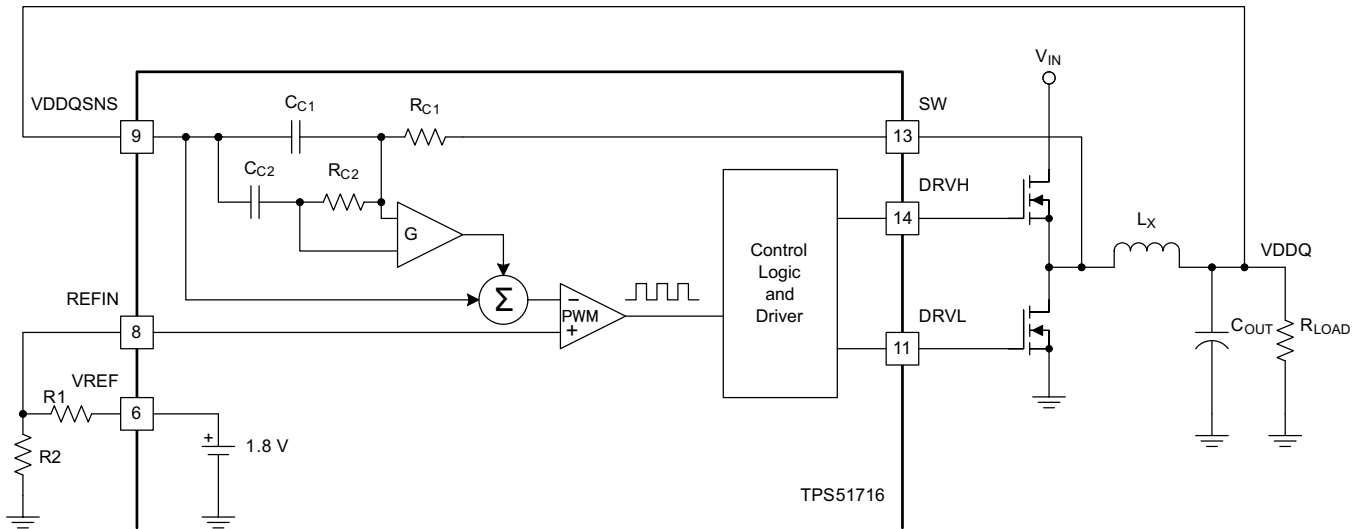

Copyright © 2016, Texas Instruments Incorporated

Figure 24. Simplified Modulator Using D-CAP2 Mode

The D-CAP2 mode in the TPS51716 includes an internal feedback network enabling the use of very low ESR output capacitor(s) such as multi-layer ceramic capacitors. The role of the internal network is to sense the ripple component of the inductor current information and combine it with voltage feedback signal. Using  $R_{C1} = R_{C2} \equiv R_C$  and  $C_{C1} = C_{C2} \equiv C_C$ , 0-dB frequency of the D-CAP2 mode is given by Equation 3. It is recommended that the 0-dB frequency ( $f_0$ ) be lower than 1/3 of the switching frequency to secure the proper phase margin.

$$f_0 = \frac{R_C \times C_C}{2\pi \times G \times L_X \times C_{OUT}} \leq \frac{f_{SW}}{3}$$

where

- G is gain of the amplifier which amplifies the ripple current information generated by the compensation circuit

(3)

The typical G value is 0.25, and typical  $R_C C_C$  time constant values for 500 kHz and 670 kHz operation are 23  $\mu$ s and 14.6  $\mu$ s, respectively.

For example, when  $f_{SW}=500$  kHz and  $L_X=1$   $\mu$ H,  $C_{OUT}$  should be larger than 88  $\mu$ F.

When selecting the capacitor, pay attention to its characteristics. For MLCC use X5R or better dielectric and consider the derating of the capacitance by both DC bias and AC bias. When derating by DC bias and AC bias are 80% and 50%, respectively, the effective derating is 40% because  $0.8 \times 0.5 = 0.4$ . The capacitance of specialty polymer capacitors may change depending on the operating frequency. Consult capacitor manufacturers for specific characteristics.

### 7.4.4 Light-Load Operation

In auto-skip mode, the TPS51716 SMPS control logic automatically reduces its switching frequency to improve light-load efficiency. To achieve this intelligence, a zero cross detection comparator is used to prevent negative inductor current by turning off the low-side MOSFET. Equation 4 shows the boundary load condition of this skip mode and continuous conduction operation.

$$I_{LOAD(LL)} = \frac{(V_{IN} - V_{OUT})}{2 \times L_X} \times \frac{V_{OUT}}{V_{IN}} \times \frac{1}{f_{SW}}$$

(4)

## 8 Application and Implementation

### NOTE

Information in the following applications sections is not part of the TI component specification, and TI does not warrant its accuracy or completeness. TI's customers are responsible for determining suitability of components for their purposes. Customers should validate and test their design implementation to confirm system functionality.

### 8.1 Application Information

TPS51716 is typically used as step down converters, which converts a voltage from 3V- 28V to 0.7 V to 1.8 V output voltage and provide a total solution to memory system.

### 8.2 Typical Application

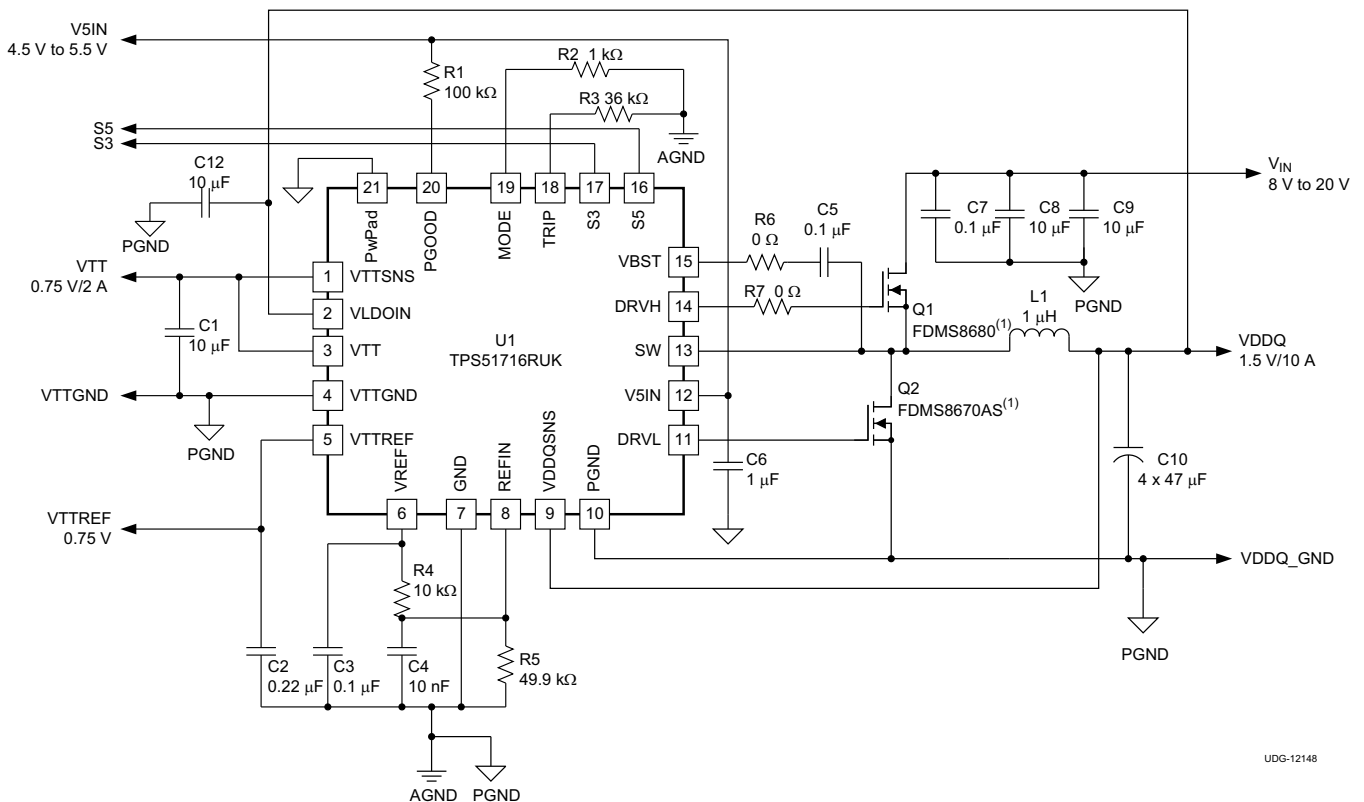

UDG-12148

Copyright © 2016, Texas Instruments Incorporated

(1) TI NexFET™ power MOSFETs are available and can be used in this application. Please contact your local TI representative.

Figure 25. DDR3, DCAP-2 500-kHz Application Circuit, Tracking Discharge

Table 3. DDR3, DCAP-2 500-kHz Application Circuit, List of Materials

REFERENCE DESIGNATOR	QTY	SPECIFICATION	MANUFACTURE	PART NUMBER
C8, C9	2	10 µF, 25 V	Taiyo Yuden	TMK325BJ106MM
C10	4	47 µF, 6.3 V	TDK	C2012X5R0J476M
L1	1	1 µH, 18.5 A, 2.3 mΩ	NEC Tokin	MPC1055L1R0C
Q1	1	30 V, 35 A, 8.5 mΩ	Fairchild	FDMS8680
Q2	1	30 V, 42 A, 3.5 mΩ	Fairchild	FDMS8670AS

## 8.2.1 Design Requirements

To begin the design process, the user must know a few application parameters (see [Table 4](#)).

**Table 4. Design Parameters**

PARAMETER	EXAMPLE VALUE
Input voltage range	8 to 20 V
Output voltage	1.5 V
Transient response, 1.5-A load step	$\Delta V_{out} = \pm 5\%$
Input ripple voltage	400 mV
Output ripple voltage	40 mV
Output current rating	10A
Operating frequency	670 kHz/ 500 kHz

## 8.2.2 Detailed Design Procedure

The following design procedure can be used to select component values for the TPS51716.

### 8.2.2.1 External Components Selection

The external components selection is a simple process.

1. Determine the value of R1 and R2

The output voltage is determined by the value of the voltage-divider resistor, R1 and R2. R1 is connected between VREF and REFIN pins, and R2 is connected between the REFIN pin and GND. Setting R1 to 10-k $\Omega$  is a good starting point. Determine R2 using [Equation 5](#).

$$R2 = \frac{R1}{\left( \frac{1.8}{V_{OUT} - \frac{V_{OUT(ripple)}}{2}} \right) - 1} \quad (5)$$

For an application using organic semiconductor capacitor(s) or specialty polymer capacitor(s) for the output capacitor(s), the output voltage ripple can be calculated as shown in [Equation 6](#).

$$V_{OUT(ripple)} = I_{IND(ripple)} \times ESR \quad (6)$$

For an application using ceramic capacitor(s) as the output capacitor(s), the output voltage ripple can be calculated as shown in [Equation 7](#).

$$V_{OUT(ripple)} = \frac{I_{IND(ripple)}}{8 \times C_{OUT} \times f_{SW}} \quad (7)$$

2. Choose the inductor

The inductance value should be determined to yield a ripple current of approximately  $\frac{1}{4}$  to  $\frac{1}{2}$  of maximum output current. Larger ripple current increases output ripple voltage and improves the signal-to-noise ratio and helps stable operation.

$$L_X = \frac{1}{I_{IND(ripple)} \times f_{SW}} \times \frac{(V_{IN(max)} - V_{OUT}) \times V_{OUT}}{V_{IN(max)}} = \frac{3}{I_{O(max)} \times f_{SW}} \times \frac{(V_{IN(max)} - V_{OUT}) \times V_{OUT}}{V_{IN(max)}} \quad (8)$$

The inductor needs a low direct current resistance (DCR) to achieve good efficiency, as well as enough room above peak inductor current before saturation. The peak inductor current can be estimated in [Equation 9](#).

$$I_{IND(peak)} = \frac{R_{TRIP} \times I_{TRIP}}{8 \times R_{DS(on)}} + \frac{1}{L \times f_{SW}} \times \frac{(V_{IN(max)} - V_{OUT}) \times V_{OUT}}{V_{IN(max)}} \quad (9)$$

3. Choose the OCL setting resistance,  $R_{TRIP}$ 

 Combining [Equation 1](#) and [Equation 2](#),  $R_{TRIP}$  can be obtained using [Equation 10](#).

$$R_{TRIP} = \frac{8 \times \left( I_{OCL} - \left( \frac{(V_{IN} - V_{OUT})}{(2 \times L_X)} \right) \times \frac{V_{OUT}}{(f_{SW} \times V_{IN})} \right) \times R_{DS(on)}}{I_{TRIP}} \quad (10)$$

## 4. Choose the output capacitors

 Determine output capacitance to meet small signal stability as shown in [Equation 11](#).

$$\frac{R_C \times C_C}{2\pi \times G \times L_X \times C_{OUT}} \leq \frac{f_{SW}}{3}$$

where

- $R_C \times C_C$  time constant is 23  $\mu$ s for 500 kHz operation (or 14.6  $\mu$ s for 670-kHz operation)
- $G = 0.25$

(11)

8.2.3 Application Curves

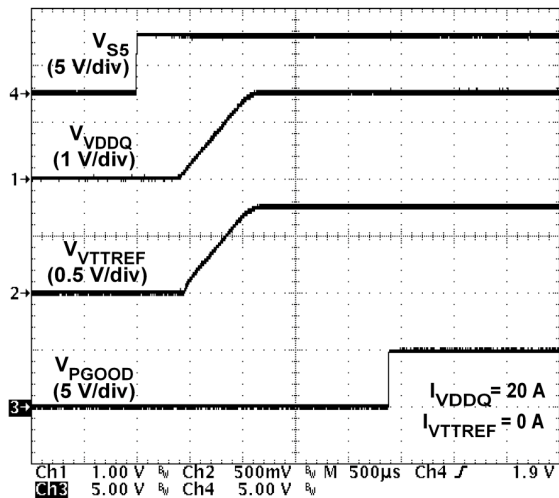

Figure 26. 1.5-V Startup Waveforms

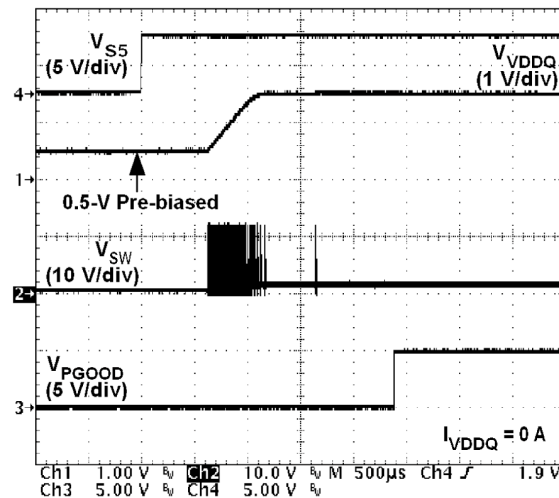

Figure 27. 1.5-V Startup Waveforms (0.5-V Pre-Biased)

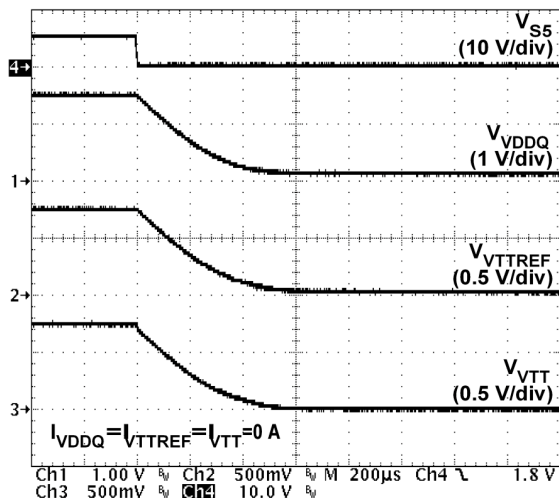

Figure 28. 1.5-V Soft-Stop Waveforms (Tracking Discharge)

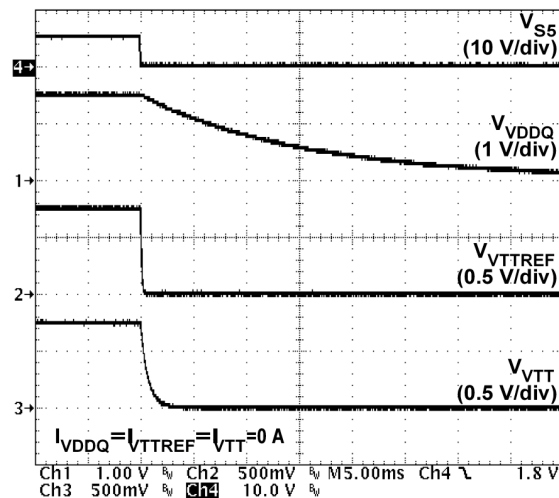
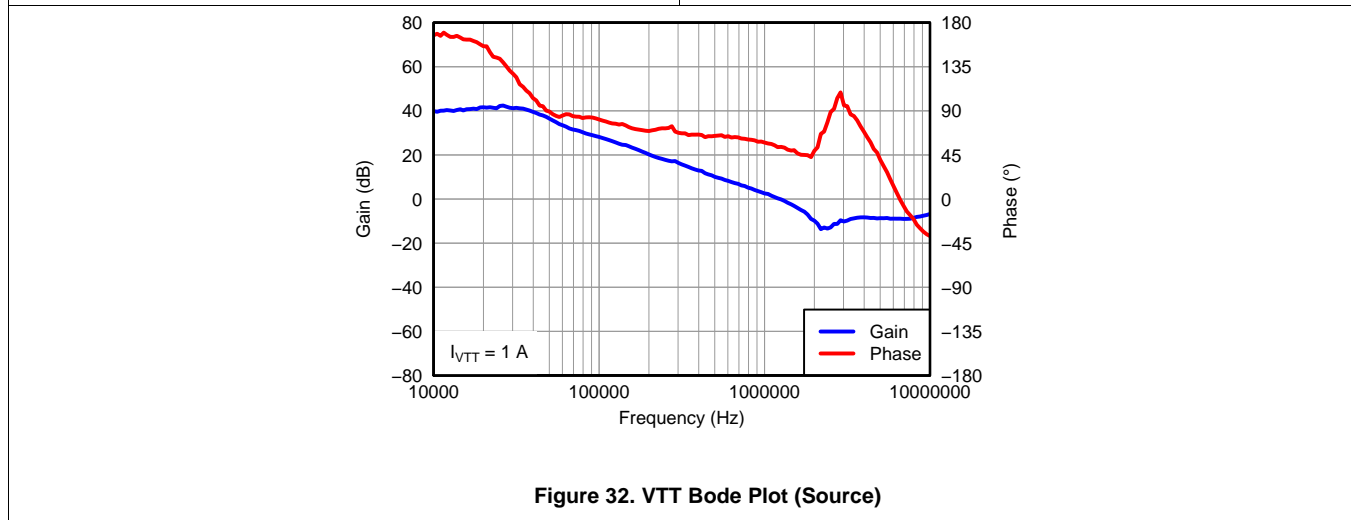
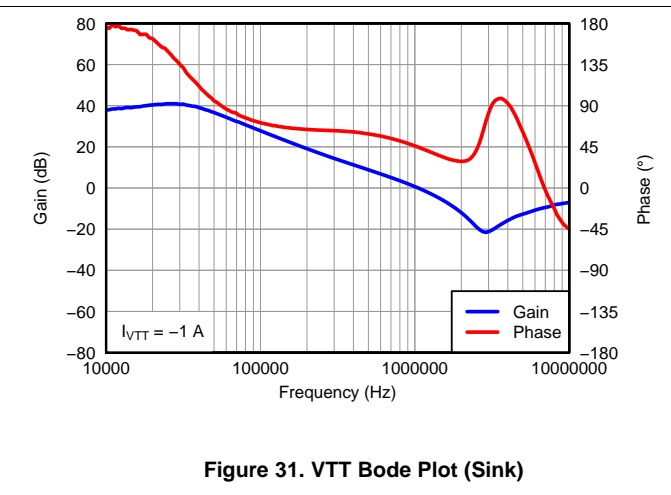
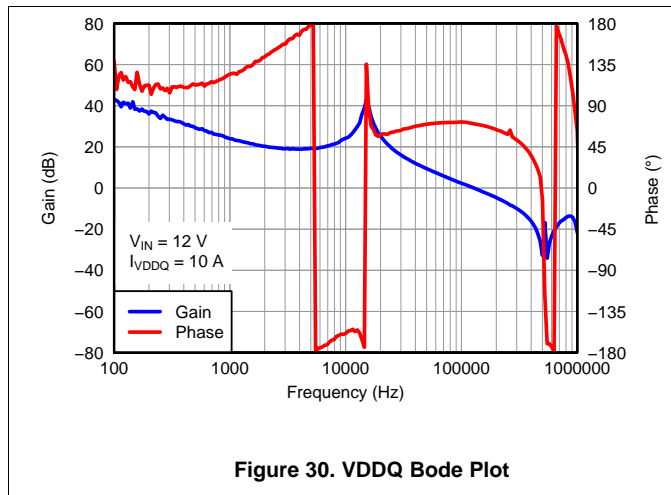

Figure 29. 1.5-V Soft-Stop Waveforms (Non-Tracking Discharge)



## 9 Power Supply Recommendations

The TPS51367 is designed to operate from input supply voltage in the range of 3 V to 28 V. Buck converters require the input voltage to be higher than the output voltage for proper operation. The maximum recommended operating duty cycle is 75%. Using that criteria, the minimum recommended input voltage is  $V_O / 0.75$ .

## 10 Layout

### 10.1 Layout Guidelines

Certain issues must be considered before designing a layout using the TPS51716.

- VIN capacitor(s), VOUT capacitor(s) and MOSFETs are the power components and should be placed on one side of the PCB (solder side). Other small signal components should be placed on another side (component side). At least one inner system GND plane should be inserted, in order to shield and isolate the small signal traces from noisy power lines.
- All sensitive analog traces and components such as VDDQSNS, VTTSNS, MODE, REFIN, VREF and TRIP should be placed away from high-voltage switching nodes such as SW, DRV\_L, DRV\_H or VBST to avoid coupling. Use internal layer(s) as system GND plane(s) and shield feedback trace from power traces and components.
- The DC/DC converter has several high-current loops. The area of these loops should be minimized in order to suppress generating switching noise.
  - The most important loop to minimize the area of is the path from the VIN capacitor(s) through the high and low-side MOSFETs, and back to the negative node of the VIN capacitor(s). Connect the negative node of the VIN capacitor(s) and the source of the low-side MOSFET as close as possible. (Refer to loop #1 of [Figure 33](#))
  - The second important loop is the path from the low-side MOSFET through inductor and VOUT capacitor(s), and back to source of the low-side MOSFET. Connect the source of the low-side MOSFET and negative node of VOUT capacitor(s) as close as possible. (Refer to loop #2 of [Figure 33](#))
  - The third important loop is of gate driving system for the low-side MOSFET. To turn on the low-side MOSFET, high current flows from V5IN capacitor through gate driver and the low-side MOSFET, and back to negative node of the capacitor. To turn off the low-side MOSFET, high current flows from gate of the low-side MOSFET through the gate driver and PGND pin, and back to source of the low-side MOSFET. Connect negative node of V5IN capacitor, source of the low-side MOSFET and PGND pin as close as possible. (Refer to loop #3 of [Figure 33](#))
- Connect negative nodes of the VTTREF output capacitor, VREF capacitor and REFIN capacitor and bottom-side resistance of VREF voltage-divider to GND pin as close as possible. The negative node of the VTT output capacitor(s), VTTGND, GND and PGND pins should be connected to system GND plane near the device as shown in [Figure 33](#).
- Because the TPS51716 controls output voltage referring to voltage across VOUT capacitor, VDDQSNS should be connected to the positive node of VOUT capacitor using different trace from that for VLDOIN. Remember that this sensing potential is the reference voltage of VTTREF. Avoid any noise generative lines. GND pin refers to the negative node of VOUT capacitor.
- Connect the overcurrent setting resistor from TRIP pin to GND pin and make the connections as close as possible to the device to avoid coupling from a high-voltage switching node.
- Connect the frequency and mode setting resistor from MODE pin to GND pin ground, and make the connections as close as possible to the device to avoid coupling from a high-voltage switching node.
- Connections from gate drivers to the respective gate of the high-side or the low-side MOSFET should be as short as possible to reduce stray inductance. Use 0.65 mm (25 mils) or wider trace and via(s) of at least 0.5 mm (20 mils) diameter along this trace.
- The PCB trace defined as SW node, which connects to the source of the high-side MOSFET, the drain of the low-side MOSFET and the high-voltage side of the inductor, should be as short and wide as possible.
- VLDOIN should be connected to VOUT with short and wide traces. An input bypass capacitor should be placed as close as possible to the pin with short and wide connections. The negative node of the capacitor should be connected to system GND plane.
- The output capacitor for VTT should be placed close to the pins with a short and wide connection in order to avoid additional ESR and/or ESL of the trace.
- VTTSNS should be connected to the positive node of the VTT output capacitor(s) using a separate trace from the high-current power line. When remote sensing is required attach the output capacitor(s) at that point. Also, it is recommended to minimize any additional ESR and/or ESL of ground trace between GND pin and the output capacitor(s).
- Consider adding a low pass filter (LPF) at VTTSNS in case the ESR of the VTT output capacitor(s) is larger than 2 mΩ.

## Layout Guidelines (continued)

- In order to effectively remove heat from the package, prepare a thermal land and solder to the package thermal pad. Wide trace of the component-side copper, connected to this thermal land, helps heat spreading. Numerous vias with a 0.3-mm diameter connected from the thermal land to the internal/solder-side ground plane(s) should be used to help dissipation. The thermal land can be connected to either AGND or PGND but is recommended to be connected to PGND, the system GND plane(s), which has better heat radiation.

## 10.2 Layout Example

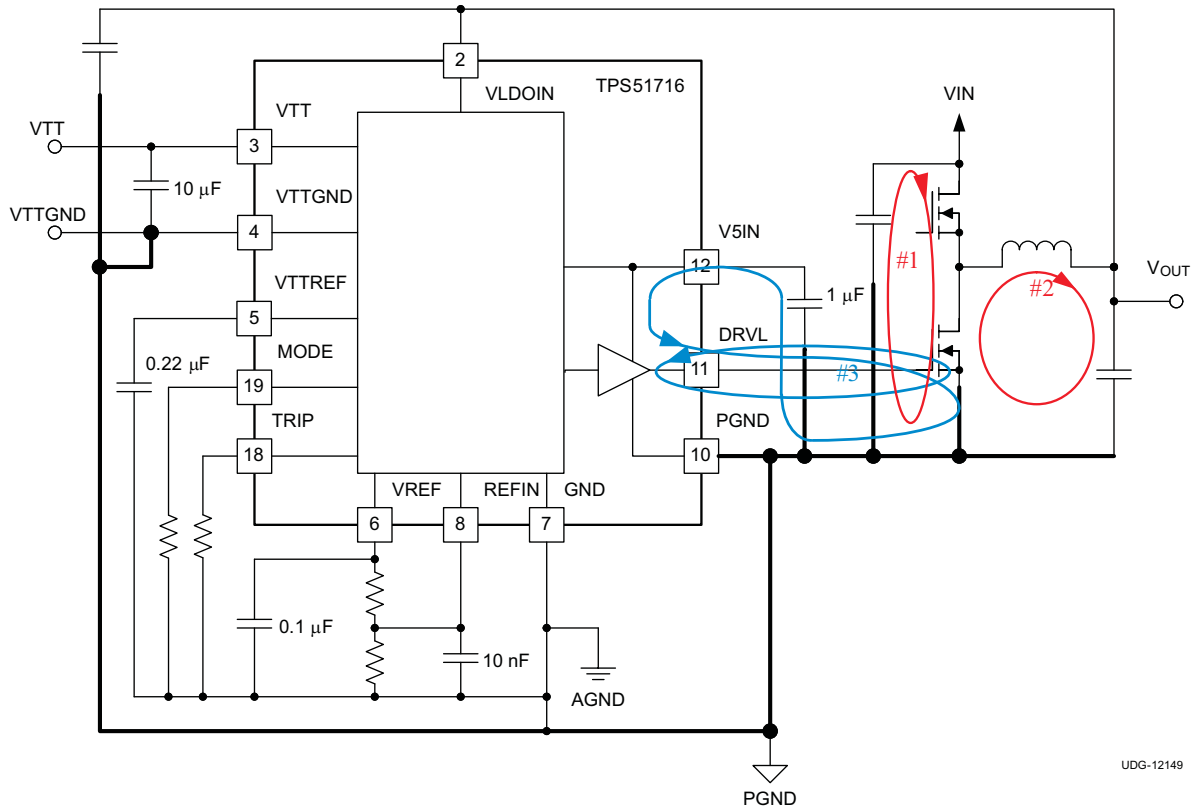

**Figure 33. DC/DC Converter Ground System**



## 11 器件和文档支持

### 11.1 器件支持

#### 11.1.1 Third-Party Products Disclaimer

TI'S PUBLICATION OF INFORMATION REGARDING THIRD-PARTY PRODUCTS OR SERVICES DOES NOT CONSTITUTE AN ENDORSEMENT REGARDING THE SUITABILITY OF SUCH PRODUCTS OR SERVICES OR A WARRANTY, REPRESENTATION OR ENDORSEMENT OF SUCH PRODUCTS OR SERVICES, EITHER ALONE OR IN COMBINATION WITH ANY TI PRODUCT OR SERVICE.

### 11.2 文档支持

#### 11.2.1 接收文档更新通知

要接收文档更新通知，请导航至 [TI.com](http://TI.com) 上的器件产品文件夹。单击右上角的 [通知我](#) 进行注册，即可每周接收产品信息更改摘要。有关更改的详细信息，请查看任何已修订文档中包含的修订历史记录。

#### 11.2.2 社区资源

下列链接提供到 TI 社区资源的连接。链接的内容由各个分销商“按照原样”提供。这些内容并不构成 TI 技术规范，并且不一定反映 TI 的观点；请参阅 TI 的 [《使用条款》](#)。

**TI E2E™ 在线社区** [TI 的工程师对工程师 \(E2E\) 社区](#)。此社区的创建目的在于促进工程师之间的协作。在 [e2e.ti.com](http://e2e.ti.com) 中，您可以咨询问题、分享知识、拓展思路并与同行工程师一道帮助解决问题。

**设计支持** [TI 参考设计支持](#) 可帮助您快速查找有帮助的 E2E 论坛、设计支持工具以及技术支持的联系信息。

### 11.3 商标

D-CAP2, NexFET, E2E are trademarks of Texas Instruments.  
All other trademarks are the property of their respective owners.

### 11.4 静电放电警告



这些装置包含有限的内置 ESD 保护。存储或装卸时，应将导线一起截短或将装置放置于导电泡棉中，以防止 MOS 门极遭受静电损伤。

### 11.5 Glossary

[SLYZ022](#) — *TI Glossary*.

This glossary lists and explains terms, acronyms, and definitions.

## 12 机械、封装和可订购信息

以下页面包含机械、封装和可订购信息。这些信息是指定器件的最新可用数据。这些数据如有变更，恕不另行通知和修订此文档。如欲获取此数据表的浏览器版本，请参阅左侧的导航。

**PACKAGING INFORMATION**

Orderable Device	Status (1)	Package Type	Package Drawing	Pins	Package Qty	Eco Plan (2)	Lead finish/ Ball material (6)	MSL Peak Temp (3)	Op Temp (°C)	Device Marking (4/5)	Samples
TPS51716RUKR	ACTIVE	WQFN	RUK	20	3000	RoHS & Green	NIPDAU	Level-2-260C-1 YEAR	-40 to 85	51716	<a href="#">Samples</a>
TPS51716RUKT	ACTIVE	WQFN	RUK	20	250	RoHS & Green	NIPDAU	Level-2-260C-1 YEAR	-40 to 85	51716	<a href="#">Samples</a>

(1) The marketing status values are defined as follows:

**ACTIVE:** Product device recommended for new designs.

**LIFEBUY:** TI has announced that the device will be discontinued, and a lifetime-buy period is in effect.

**NRND:** Not recommended for new designs. Device is in production to support existing customers, but TI does not recommend using this part in a new design.

**PREVIEW:** Device has been announced but is not in production. Samples may or may not be available.

**OBSOLETE:** TI has discontinued the production of the device.

(2) **RoHS:** TI defines "RoHS" to mean semiconductor products that are compliant with the current EU RoHS requirements for all 10 RoHS substances, including the requirement that RoHS substance do not exceed 0.1% by weight in homogeneous materials. Where designed to be soldered at high temperatures, "RoHS" products are suitable for use in specified lead-free processes. TI may reference these types of products as "Pb-Free".

**RoHS Exempt:** TI defines "RoHS Exempt" to mean products that contain lead but are compliant with EU RoHS pursuant to a specific EU RoHS exemption.

**Green:** TI defines "Green" to mean the content of Chlorine (Cl) and Bromine (Br) based flame retardants meet JS709B low halogen requirements of <=1000ppm threshold. Antimony trioxide based flame retardants must also meet the <=1000ppm threshold requirement.

(3) MSL, Peak Temp. - The Moisture Sensitivity Level rating according to the JEDEC industry standard classifications, and peak solder temperature.

(4) There may be additional marking, which relates to the logo, the lot trace code information, or the environmental category on the device.

(5) Multiple Device Markings will be inside parentheses. Only one Device Marking contained in parentheses and separated by a "~" will appear on a device. If a line is indented then it is a continuation of the previous line and the two combined represent the entire Device Marking for that device.

(6) Lead finish/Ball material - Orderable Devices may have multiple material finish options. Finish options are separated by a vertical ruled line. Lead finish/Ball material values may wrap to two lines if the finish value exceeds the maximum column width.

**Important Information and Disclaimer:**The information provided on this page represents TI's knowledge and belief as of the date that it is provided. TI bases its knowledge and belief on information provided by third parties, and makes no representation or warranty as to the accuracy of such information. Efforts are underway to better integrate information from third parties. TI has taken and continues to take reasonable steps to provide representative and accurate information but may not have conducted destructive testing or chemical analysis on incoming materials and chemicals. TI and TI suppliers consider certain information to be proprietary, and thus CAS numbers and other limited information may not be available for release.

In no event shall TI's liability arising out of such information exceed the total purchase price of the TI part(s) at issue in this document sold by TI to Customer on an annual basis.



**TAPE AND REEL INFORMATION**

**QUADRANT ASSIGNMENTS FOR PIN 1 ORIENTATION IN TAPE**

\*All dimensions are nominal

Device	Package Type	Package Drawing	Pins	SPQ	Reel Diameter (mm)	Reel Width W1 (mm)	A0 (mm)	B0 (mm)	K0 (mm)	P1 (mm)	W (mm)	Pin1 Quadrant
TPS51716RUKR	WQFN	RUK	20	3000	330.0	12.4	3.3	3.3	1.1	8.0	12.0	Q2
TPS51716RUKR	WQFN	RUK	20	3000	330.0	12.4	3.3	3.3	1.1	8.0	12.0	Q2
TPS51716RUKT	WQFN	RUK	20	250	180.0	12.5	3.3	3.3	1.1	8.0	12.0	Q2
TPS51716RUKT	WQFN	RUK	20	250	180.0	12.4	3.3	3.3	1.1	8.0	12.0	Q2

**TAPE AND REEL BOX DIMENSIONS**

\*All dimensions are nominal

Device	Package Type	Package Drawing	Pins	SPQ	Length (mm)	Width (mm)	Height (mm)
TPS51716RUKR	WQFN	RUK	20	3000	356.0	356.0	35.0
TPS51716RUKR	WQFN	RUK	20	3000	338.0	355.0	50.0
TPS51716RUKT	WQFN	RUK	20	250	205.0	200.0	33.0
TPS51716RUKT	WQFN	RUK	20	250	210.0	185.0	35.0

# RUK0020B

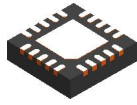

# PACKAGE OUTLINE

## WQFN - 0.8 mm max height

PLASTIC QUAD FLATPACK - NO LEAD

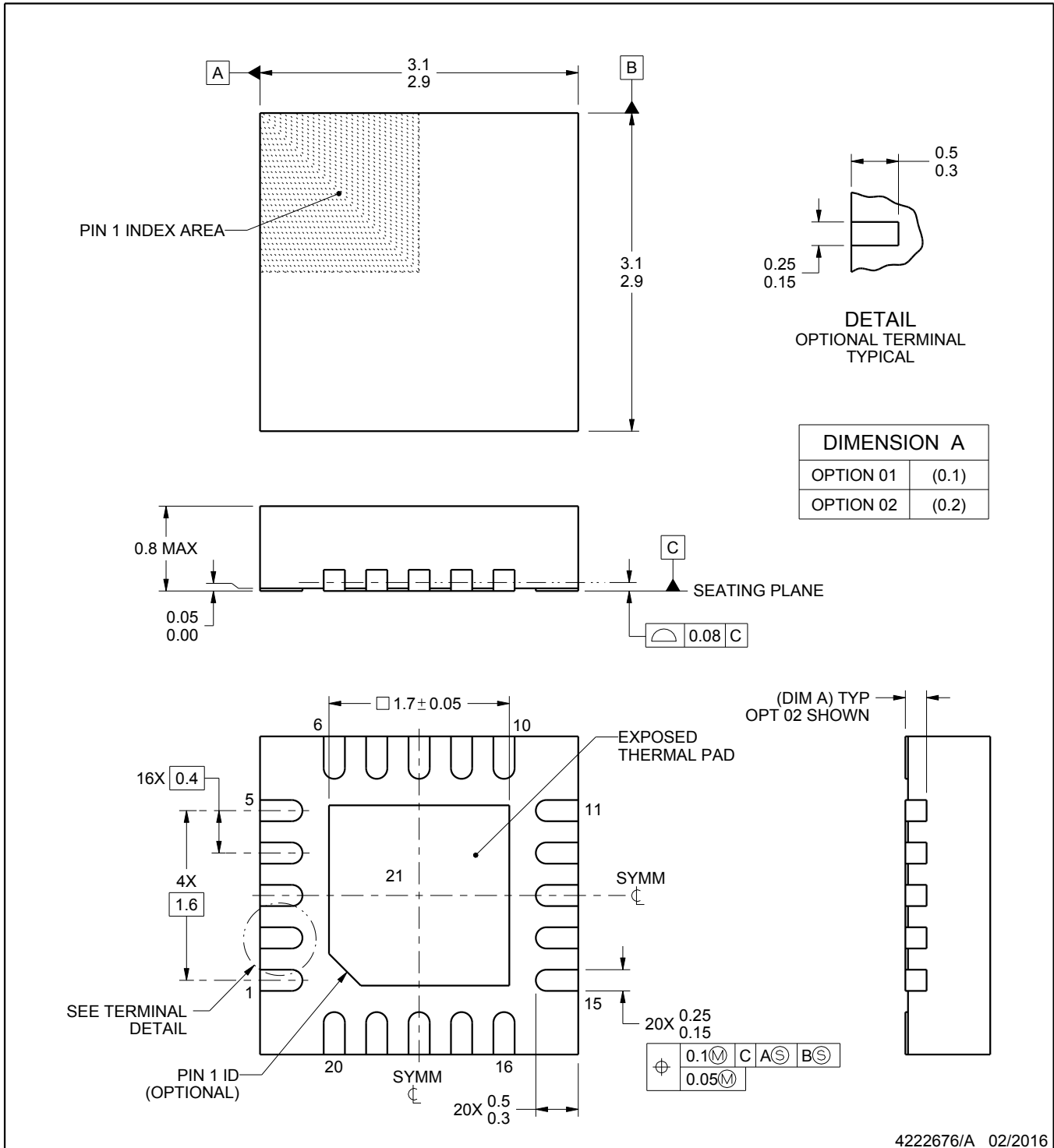

4222676/A 02/2016

**NOTES:**

1. All linear dimensions are in millimeters. Any dimensions in parenthesis are for reference only. Dimensioning and tolerancing per ASME Y14.5M.
2. This drawing is subject to change without notice.
3. The package thermal pad must be soldered to the printed circuit board for thermal and mechanical performance.

# EXAMPLE BOARD LAYOUT

RUK0020B

WQFN - 0.8 mm max height

PLASTIC QUAD FLATPACK - NO LEAD

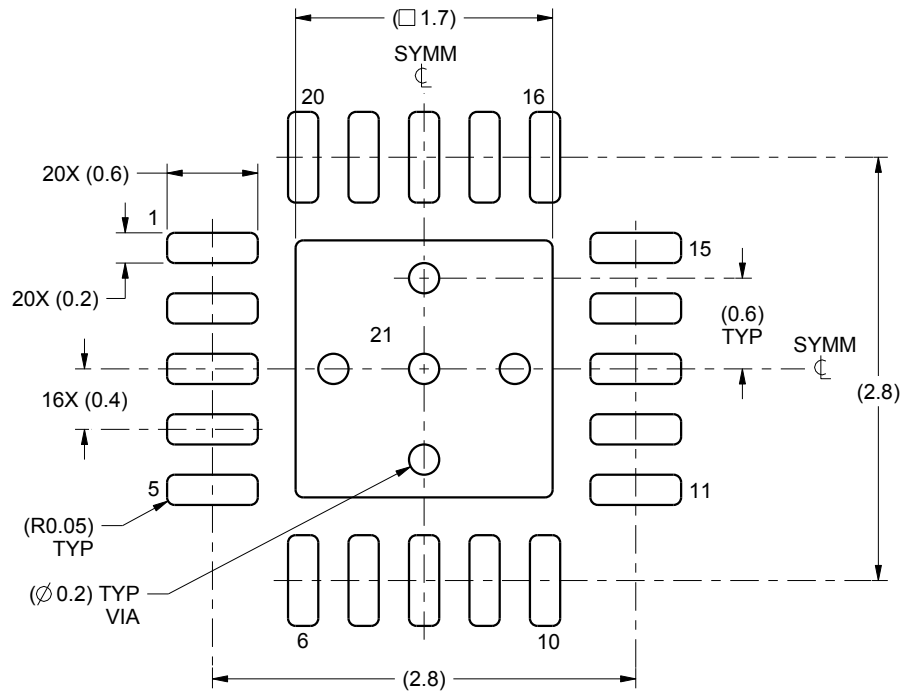

LAND PATTERN EXAMPLE  
SCALE:20X

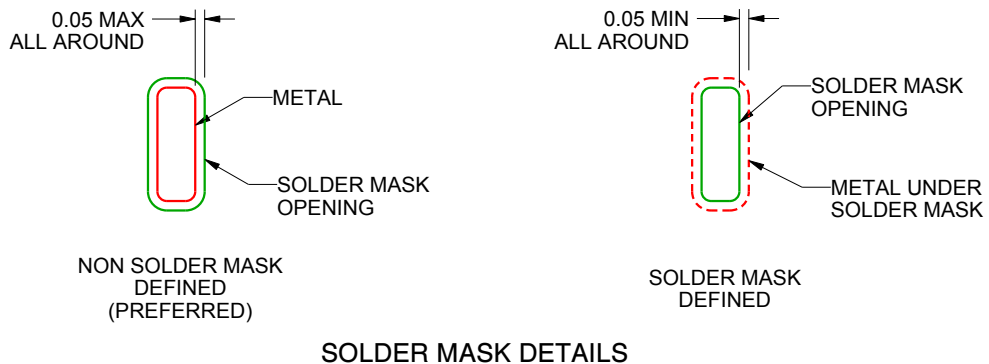

SOLDER MASK DETAILS

4222676/A 02/2016

NOTES: (continued)

4. This package is designed to be soldered to a thermal pad on the board. For more information, see Texas Instruments literature number SLUA271 ([www.ti.com/lit/sluea271](http://www.ti.com/lit/sluea271)).
5. Vias are optional depending on application, refer to device data sheet. If any vias are implemented, refer to their locations shown on this view. It is recommended that vias under paste be filled, plugged or tented.

# EXAMPLE STENCIL DESIGN

RUK0020B

WQFN - 0.8 mm max height

PLASTIC QUAD FLATPACK - NO LEAD

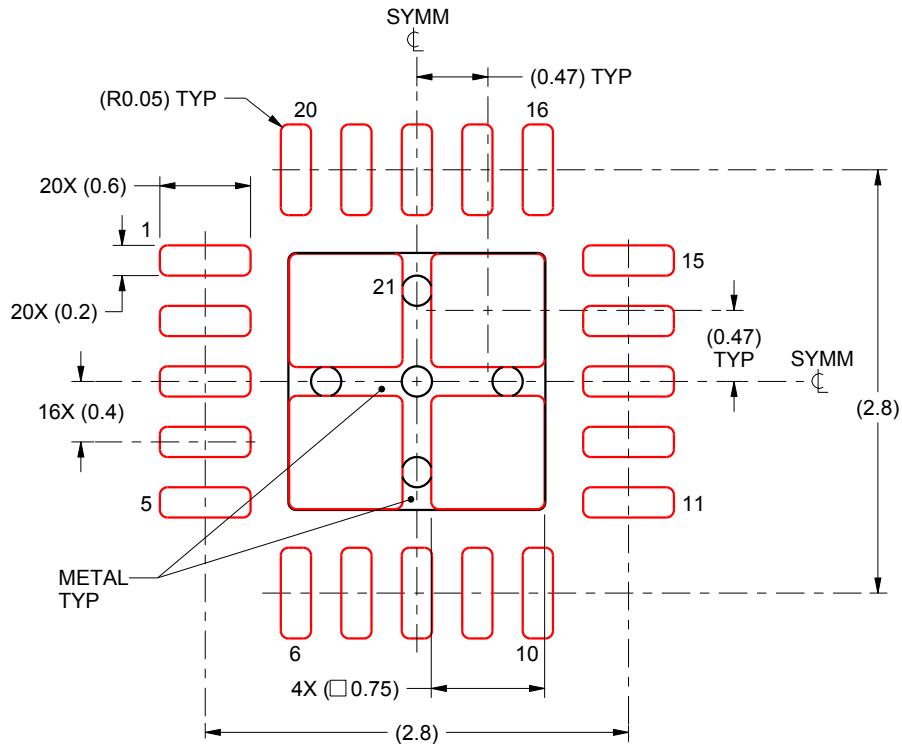

## SOLDER PASTE EXAMPLE BASED ON 0.1 mm THICK STENCIL

EXPOSED PAD 21:  
78% PRINTED SOLDER COVERAGE BY AREA UNDER PACKAGE  
SCALE:20X

4222676/A 02/2016

NOTES: (continued)

6. Laser cutting apertures with trapezoidal walls and rounded corners may offer better paste release. IPC-7525 may have alternate design recommendations.



## 重要声明和免责声明

TI“按原样”提供技术和可靠性数据（包括数据表）、设计资源（包括参考设计）、应用或其他设计建议、网络工具、安全信息和其他资源，不保证没有瑕疵且不做任何明示或暗示的担保，包括但不限于对适销性、某特定用途方面的适用性或不侵犯任何第三方知识产权的暗示担保。

这些资源可供使用 TI 产品进行设计的熟练开发人员使用。您将自行承担以下全部责任：(1) 针对您的应用选择合适的 TI 产品，(2) 设计、验证并测试您的应用，(3) 确保您的应用满足相应标准以及任何其他功能安全、信息安全、监管或其他要求。

这些资源如有变更，恕不另行通知。TI 授权您仅可将这些资源用于研发本资源所述的 TI 产品的应用。严禁对这些资源进行其他复制或展示。您无权使用任何其他 TI 知识产权或任何第三方知识产权。您应全额赔偿因在这些资源的使用中对 TI 及其代表造成的任何索赔、损害、成本、损失和债务，TI 对此概不负责。

TI 提供的产品受 [TI 的销售条款](#) 或 [ti.com](#) 上其他适用条款/TI 产品随附的其他适用条款的约束。TI 提供这些资源并不会扩展或以其他方式更改 TI 针对 TI 产品发布的适用的担保或担保免责声明。

TI 反对并拒绝您可能提出的任何其他或不同的条款。

邮寄地址：Texas Instruments, Post Office Box 655303, Dallas, Texas 75265

Copyright © 2022，德州仪器 (TI) 公司