

有关敝公司产品的注意事项

请务必在使用敝公司产品之前阅读。

注意

产品目录中的记载内容

本产品目录中所记载的内容为2021年10月的内容。因产品改良等原因，可能会不经预告而变更其记载内容，或是停止供应本产品目录中所记载的产品。所以，请务必在使用前先确认最新的产品信息。

未按照本产品目录中所记载的内容或交货规格说明书使用敝公司产品的，即便其致使用设备发生损害、不良情况等时，敝公司也不承担任何责任，敬请知悉。

签署交货规格说明书

就本产品目录中所记载产品的产品规格等相关内容，敝公司备有交货规格说明书，详情请向敝公司咨询。在使用敝公司产品前请务必就交货规格说明书之内容确认并批准之。

实装前的事前评估

使用敝公司产品时，请务必事先安装到使用设备之后，在实际使用的环境下进行评估和确认。

安全设计

需将敝公司的产品使用于对安全性和可靠性要求较高的设备、电路上时，请进行充分的安全性评估和可靠性评估。另外，请通过设置保护电路、保护装置的系统，设置冗余电路不会被单一故障影响安全性的系统等失效导向安全（fail-safe）设计，确保充分的安全性。

有关知识产权

本产品目录中所记载的信息是用于说明相关产品的典型操作以及相关应用。此类信息的使用不代表对于敝公司以及第三方的知识产权以及其他权利的使用许可或是不侵权保证。

保证范围

敝公司产品的保证范围仅限于符合交货规格说明书中所记载的产品规格且已经交付的敝公司产品本身，由敝公司产品的故障或不良情况所诱发的损害，敝公司不承担任何责任，敬请知悉。但是，仅限于敝公司的产品作为通用性，标准性用途使用于本产品目录或是交货规格说明书中另行注明的设备，且以书面形式另行签署了交易基本合同书，品质保证协定书等时，敝公司将根据该合同等的条件提供保证。

正规销售渠道

本产品目录中所记载的内容适用于从敝公司营业所、销售子公司、销售代理店（即“正规销售渠道”）购买的敝公司产品，并不适用于从其他渠道购买的敝公司产品，敬请知悉。

出口时的注意事项

本产品目录中所记载的部分产品在出口时须事先确认《外汇和对外贸易法》以及美国在出口管理方面的相关法规，并办理相关手续。如有不明之处，请向敝公司咨询。

▶ 由于篇幅有限，本产品目录中只记载了有代表性的产品规格，若考虑使用敝公司产品时，请确认交货规格说明书中的详细规格。另外，有关各产品的详细信息（特性图、可靠性信息、使用时的注意事项等），请参阅敝公司网站（<http://www.ty-top.com/>）。

■ 用途的限定

1. 可以使用的设备

本产品目录中所记载的产品预设为使用于一般民用电子设备〔音像设备、办公自动化设备、家电产品、办公设备、信息通讯设备（手机、电脑等）〕以及面向本产品目录或是交货规格说明书中另行注明的设备或是敝公司另行承诺的设备的通用性，标准性用途。另外，面向下述设备的应用，敝公司也备有预设的产品系列，请参考本产品目录或是交货规格说明书的内容，使用相对应的产品。

用途	产品系列		品质等级 ^(注释3)
	对象设备 ^(注释1)	规格号 (型号标记 ^(注释2))	
车载	汽车用电子设备（控制系 / 安全系）	A	1
	汽车用电子设备（车身系 / 情报系）	C	2
工业	通信基础设备 · 工业设备	B	2
医疗	医疗设备（国际（GHTF）第三类）	M	2
	医疗设备（国际（GHTF）第一类、第二类）	L	3
民用	一般电子设备	S	3

注释1：基于敝公司所认知的该类设备对于电子元器件所需的一般要求规格，对于该产品系列进行的应用推荐。在讨论将各个产品系列使用在对象设备以外的设备上时，请务必事先向敝公司咨询。

注释2：在产品型号中左起第2位标注有上表中所记载的规格号。对于相关的详细内容，请参照有关各产品型号标示法的说明资料。

注释3：在各产品系列中，都设定了从上至下1至3的“品质等级”。另外，在未得到敝公司的事前书面承诺之前，请勿将敝公司的产品使用于相对于该产品的品质等级被设定为上位品质等级的设备。

2. 需要另行确认的设备

若考虑将本产品目录中所记载的产品使用于当产品发生故障、品质不良，或是由此引起的运转失常而可能会危及生命、身体或是财产，以及有可能给社会造成深刻影响的以下设备（不包括本产品目录或是交货规格说明书中另行注明可以使用设备）等时，请务必事先向敝公司咨询。

- (1) 运输用设备（汽车驱动控制设备、火车控制设备、船舶控制设备等）
- (2) 交通信号设备
- (3) 防灾 / 保安设备
- (4) 医疗设备（国际（GHTF）第三类）
- (5) 高公共性信息通讯设备 / 信息处理设备（电话交换机、电话 / 无线 / 广播电视基站等）
- (6) 其他与上述设备有同等品质与可靠性要求的设备

3. 禁止使用的设备

请勿将敝公司产品使用于对安全性和可靠性有着极高要求的以下设备。

- (1) 航天设备（人工卫星、火箭等）
- (2) 航空设备^(注释1)
- (3) 医疗设备（国际（GHTF）第四类）、植体（体内植入型）医疗设备^(注释2)
- (4) 发电控制设备（面向核能 / 水力 / 火力发电厂等的设备）
- (5) 海底设备（海底中继设备、海中的作业设备等）
- (6) 军事设备
- (7) 其他与上述设备有同等品质与可靠性要求的设备

注释1：仅限于对航空设备的安全运行不产生直接干扰的设备〔机内娱乐设备、机内照明设备、电动座椅、餐饮设备等〕，在满足敝公司另行指定的相关条件时，亦可将敝公司产品用于以上用途。在贵公司考虑将敝公司的产品用于以上用途时，请务必事先向敝公司咨询相关的信息。

注释2：包括注入人体内的部分和与此相连接的体外部分。

4. 责任的限制

未经敝公司的事先书面同意，把本产品目录中所记载的产品使用于非敝公司预设用途的设备、前述需要向敝公司咨询的设备或敝公司禁止使用的设备，从而给客户或第三方造成损害的，敝公司不承担任何责任，敬请知悉。

车载用途使用指引

敝公司将汽车用电子设备划分为如下四个分类。而对于敝公司的每个产品，敝公司都设定了其可以被使用的分类，以及相对应的产品系列（左起第二位的产品型号的记号为“A”或是“C”）。因此，需在汽车用电子设备上使用敝公司的产品之前，请务必事先确认该产品系列是否适合使用该用途上。如有不明之处，请与敝公司取得联系。

产品系列 (左起第二位的产品型号的记号)	分 类	汽车用电子设备（代表实例）
A	控制系	<ul style="list-style-type: none"> • 发动机引擎控制装置（ECU） • 巡航定速控制装置 • 四轮转向系统（4WS） • 自动变速箱（AT） • 动力转向装置 • HEV/PHV/EV 基础控制（电池 / 逆变器 /DC-DC） • 汽车定位器（车辆位置情报提供装置） 等
	安全系	<ul style="list-style-type: none"> • 防锁死刹车系统（ABS） • 车身动态稳定系统（ESC） • 安全气囊 • ADAS（直接控制走动 / 转向 / 停车的装置） 等
C	车身系	<ul style="list-style-type: none"> • 雨刷 • 自动门锁 • 电动车窗 • 无钥匙进入系统（智能钥匙） • 电动后视镜 • 汽车电子后视镜 • 车内照明 • 车内空调系统 • 轮胎压力监测系统（TPMS） • 防盗装置 等
	情报系	<ul style="list-style-type: none"> • 车载信息娱乐装置（汽车导航 / 音响等） • 情报通讯装置（ITS/T-BOX） • 汽车仪表 • ADAS（与传感，安全 / 传动系统没有关联的装置） • 行车记录仪（车厂原装配件） 等

车载(车身系 / 情报系)用途 多层陶瓷电容器

回流焊

AEC-Q200

■型号标示法

M	C	A	S	J	3	1	L	S	B	5	1	0	6	K	T	N	A	0	1
①	②	③	④	⑤	⑥	⑦	⑧	⑨	⑩										

①系列

代码 (1)(2)(3)(4)	
MCAS	车载(车身系 / 情报系)用途 多层陶瓷电容器 (高介电常数) 车载(车身系 / 情报系)用途 多层陶瓷电容器 (温度补偿用) 车载(车身系 / 情报系)用途 中高耐压多层陶瓷电容器
MCAR	车载(车身系 / 情报系)用途 高频/低损耗中高耐压多层陶瓷电容器
MCJC	车载(车身系 / 情报系)用途 树脂外部电极多层陶瓷电容器
MCRL	车载(车身系 / 情报系)用途 LW 反转/低 ESL 多层陶瓷电容器 (LWDC™)

(1) 产品群

代码	
M	多层陶瓷电容器

(2) 范畴

代码	推荐设备	品质等级
C	汽车用电子设备(车身系 / 情报系)	2

(3) 类型

代码	
A	2 端接
J	树脂外部电极
R	LW 反转

(4) 特效 / 特性

代码	
S	标准/一般
R	高频/低损耗
C	个别规格 (树脂外部电极)
L	低 ESL

②额定电压

代码	额定电压 [VDC]
A	4
J	6.3
L	10
E	16
T	25
G	35
U	50
H	100
Q	250
S	630

④产品厚度

代码	产品厚度 [mm]
3	0.3
5	0.5
7	0.7
8	0.8
9	0.85
Q	1.15
G	1.25
L	1.6
N	1.9 (0.088 ※)
M	2.5

注: ※LW 反转型 (MCRL)

③外型尺寸

代码	L×W [mm]	JIS (mm)	EIA (inch)
06	0.6 × 0.3	0603	0201
10	1.0 × 0.5	1005	0402
	0.52 × 1.0 ※	0510	0204
16	1.6 × 0.8	1608	0603
	0.8 × 1.6 ※	0816	0306
21	2.0 × 1.25	2012	0805
	1.25 × 2.0 ※	1220	0508
31	3.2 × 1.6	3216	1206
32	3.2 × 2.5	3225	1210
45	4.5 × 3.2	4532	1812

注: ※LW 反转型 (MCRL)

⑤ 产品尺寸公差

代码	外型尺寸记号	L [mm]	W [mm]	T [mm]	产品厚度代码
A	10	1.0±0.10	0.5±0.10	0.5±0.10	5
	16	1.6+0.15/-0.05	0.8+0.15/-0.05	0.8+0.15/-0.05	8
	21	2.0+0.15/-0.05	1.25+0.15/-0.05	1.25+0.15/-0.05	G
	31	3.2±0.20	1.6±0.20	1.15±0.20	Q
				1.6±0.20	L
32	3.2±0.30	2.5±0.30	2.5±0.30	M	
B	10	1.0+0.15/-0.05	0.5+0.15/-0.05	0.5+0.15/-0.05	5
	16	1.6+0.20/-0	0.8+0.20/-0	0.8+0.20/-0	8
	21	2.0+0.20/-0	1.25+0.20/-0	1.25+0.20/-0	G
	31	3.2±0.30	1.6±0.30	1.6±0.30	L
C	10	1.0+0.20/-0	0.5+0.20/-0	0.5+0.20/-0	5
	16	1.6+0.25/-0	0.8+0.25/-0	0.8+0.25/-0	8
	21	2.0+0.25/-0	1.25+0.25/-0	1.25+0.25/-0	G
D	21	2.0+0.30/-0	1.25+0.30/-0	1.25+0.30/-0	G
H	31	3.2±0.15	1.6±0.15	1.15±0.10	Q
J	21	2.0+0.15/-0.05	1.25+0.15/-0.05	0.85±0.10	9
L	21	2.0+0.20/-0	1.25+0.20/-0	0.85±0.10	9
	32	3.2±0.50	2.5±0.30	2.5±0.30	M
N	21	2.0±0.15	1.25±0.15	0.85±0.15	9
S	06	0.6±0.03	0.3±0.03	0.3±0.03	3
		1.0±0.05	0.5±0.05	0.5±0.05	5
	16	0.52±0.05 ※	1.0±0.05	0.3±0.05	3
		1.6±0.10	0.8±0.10	0.7±0.10	7
		0.8±0.10 ※	1.6±0.10	0.8±0.10	8
				0.5±0.05	5
	21	2.0±0.10	1.25±0.10	0.85±0.10	9
		1.25±0.15 ※	2.0±0.15	1.25±0.10	G
				0.85±0.10	9
	31	3.2±0.15	1.6±0.15	1.6±0.20	L
	32	3.2±0.30	2.5±0.20	1.9±0.20	N
				2.5±0.20	M
2.5±0.20				M	
45	4.5±0.40	3.2±0.30	2.5±0.20	M	

注：※LW 反转型 (MCRL)

⑥温度特性

■高介电常数

代码	适用标准		温度范围 [°C]	基准温度 [°C]	静电容量变化率	静电容量允许偏差	允许偏差代码
B5	EIA	X5R	-55~+85	25	±15%	±10%	K
						±20%	M
C6	EIA	X6S	-55~+105	25	±22%	±10%	K
						±20%	M
B7	EIA	X7R	-55~+125	25	±15%	±10%	K
						±20%	M
C7	EIA	X7S	-55~+125	25	±22%	±10%	K
						±20%	M
D7	EIA	X7T	-55~+125	25	+22%/-33%	±10%	K
						±20%	M

■温度補償用

代码	适用标准		温度范围 [°C]	基准温度 [°C]	静电容量变化率	静电容量允许偏差	允许偏差代码		
CG	JIS	CG	-55~+125	20	0±30ppm/°C	±0.05pF	A		
						±0.1pF	B		
	±0.25pF	C							
	±0.5pF	D							
EIA	COG	25	±2%	G					
			±5%	J					
CH	JIS	CH	-55~+125	20	0±60ppm/°C	±0.25pF	C		
						±0.5pF	D		
EIA	COH	25		±5%		J			
CJ	JIS	CJ	-55~+125	20	0±120ppm/°C	±0.25pF	C		
						EIA	COJ	25	
CK	JIS	CK		-55~+125		20	0±250ppm/°C	±0.25pF	C
								EIA	COK

⑦静电容量

代码(例)	静电容量
OR5	0.5pF
O10	1pF
100	10pF
101	100pF
102	1.000pF
103	0.01μF
104	0.1μF
105	1μF
106	10μF
107	100μF

注: R=小数点

⑧静电容量允许偏差

代码	静电容量允许偏差
A	±0.05pF
B	±0.1pF
C	±0.25pF
D	±0.5pF
G	±2%
J	±5%
K	±10%
M	±20%

⑨包装

代码	包装规格
F	φ178mm 卷盘带装 (2mm 间隔)
R	φ178mm 压模带 (4mm 间隔)
T	φ178mm 卷盘带装 (4mm 间隔)
P	φ178mm 卷盘带装 (4mm 间隔, 1000 个/卷盘) 3225 规格 (厚度代码 M)

⑩管理记号

■标准产品尺寸

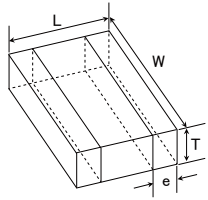
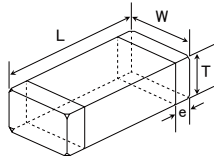

※LW 反转型

Type	JIS (mm)	EIA (inch)	标准产品尺寸 [mm] (inch)				
			L	W	T	*1	e
MCAS□06	0603	0201	0.6±0.03 (0.024±0.001)	0.3±0.03 (0.012±0.001)	0.3±0.03 (0.012±0.001)	3	0.15±0.05 (0.006±0.002)
MCAR□10 MCAS□10	1005	0402	1.0±0.05 (0.039±0.002)	0.5±0.05 (0.020±0.002)	0.5±0.05 (0.020±0.002)	5	0.25±0.10 (0.010±0.004)
MCRL□10 ※	0510	0204	0.52±0.05 (0.020±0.002)	1.0±0.05 (0.039±0.002)	0.3±0.05 (0.012±0.002)	3	0.18±0.08 (0.007±0.003)
MCAS□16 MCAR□16	1608	0603	1.6±0.10 (0.063±0.004)	0.8±0.10 (0.031±0.004)	0.7±0.10 (0.028±0.004) 0.8±0.10 (0.031±0.004)	7 8	0.35±0.25 (0.014±0.010)
MCJC□16	1608	0603	1.6±0.10 (0.063±0.004)	0.8±0.10 (0.031±0.004)	0.8±0.10 (0.031±0.004)	8	0.35+0.3/-0.25 (0.014+0.012/-0.010)
MCRL□16 ※	0816	0306	0.8±0.10 (0.031±0.004)	1.6±0.10 (0.063±0.004)	0.5±0.05 (0.020±0.002)	5	0.25±0.15 (0.010±0.006)
MCAS□21 MCAR□21	2012	0805	2.0±0.10 (0.079±0.004)	1.25±0.10 (0.049±0.004)	0.85±0.10 (0.033±0.004) 1.25±0.10 (0.049±0.004)	9 G	0.5±0.25 (0.020±0.010)
MCJC□21	2012	0805	2.0±0.10 (0.079±0.004)	1.25±0.10 (0.049±0.004)	0.85±0.10 (0.033±0.004) 1.25±0.10 (0.049±0.004)	9 G	0.5+0.35/-0.25 (0.020+0.014/-0.010)
MCRL□21 ※	1220	0508	1.25±0.15 (0.049±0.006)	2.0±0.15 (0.079±0.006)	0.85±0.10 (0.033±0.004)	9	0.3±0.2 (0.012±0.008)
MCAS□31	3216	1206	3.2±0.15 (0.126±0.006)	1.6±0.15 (0.063±0.006)	1.15±0.10 (0.045±0.004) 1.6±0.20 (0.063±0.008)	Q L	0.5+0.35/-0.25 (0.020+0.014/-0.010)
MCJC□31	3216	1206	3.2±0.15 (0.126±0.006)	1.6±0.15 (0.063±0.006)	1.15±0.10 (0.045±0.004) 1.6±0.20 (0.063±0.008)	Q L	0.6+0.4/-0.3 (0.024+0.016/-0.012)
MCAS□32	3225	1210	3.2±0.30 (0.126±0.012)	2.5±0.20 (0.098±0.008)	1.9±0.20 (0.075±0.008) 2.5±0.20 (0.098±0.008)	N M	0.6±0.3 (0.024±0.012)
MCJC□32	3225	1210	3.2±0.30 (0.126±0.012)	2.5±0.20 (0.098±0.008)	1.9±0.20 (0.075±0.008) 2.5±0.20 (0.098±0.008)	N M	0.6+0.4/-0.3 (0.024+0.016/-0.012)
MCAS□45	4532	1812	4.5±0.40 (0.177±0.016)	3.2±0.30 (0.126±0.012)	2.5±0.20 (0.098±0.008)	M	0.9±0.6 (0.035±0.024)

注: ※LW 反转型 (MCRL)、*1 产品厚度代码

▶ 由于篇幅有限, 本产品目录中只记载了有代表性的产品规格, 若考虑使用敝公司产品时, 请确认交货规格说明书中的详细规格。
另外, 有关各产品的详细信息(特性图、可靠性信息、使用时的注意事项等), 请参阅敝公司网站(<http://www.ty-top.com/>)。

■标准包装

外型			产品厚度		标准数量 [pcs]	
代码	JIS (mm)	EIA (inch)	[mm]	代码	纸带	压模带
06	0603	0201	0.3	3	15000	—
10	1005	0402	0.5	5	10000	—
	0510 ※	0204 ※	0.3	3		
16	1608	0603	0.7	7	4000	—
			0.8	8		
			0.8	8		
	0816 ※	0306 ※	0.5	5	—	4000
21	2012	0805	0.85	9	4000	—
			1.25	G	—	3000
			1.25	G	—	2000 (树脂外部电极品)
	1220 ※	0508 ※	0.85	9	4000	—
31	3216	1206	1.15	Q	—	3000
			1.6	L	—	2000
32	3225	1210	1.9	N	—	2000
			2.5	M	—	500 (T), 1000 (P)
45	4532	1812	2.5	M	—	500

注: ※LW 反转型 (MCRL)

■型号一览

- 产品目录中的多层陶瓷电容器全部属于RoHS对应品。
- 型号的 []中将会记入静电容量允许偏差代码。
- 产品目录中的多层陶瓷电容器全部属于回流焊对应品。

注)

- 根据使用电路和机器，需要按照相应规格处理。请务必咨询正规销售渠道。
- 车载(车身系 / 情报系)用途(AEC-Q200 qualified)的产品。有关更多的内容，请务必于“车载用途使用指引”中确认。

< AEC-Q200 : AEC-Q200 qualified >

车载(控制系 / 安全系)用途的多层陶瓷电容器，已就其代表性产品实施了对应AEC-Q200标准的评价测试。

125°C products: AEC-Q200 Grade1 (已在Grade1的测试条件下评价完毕。)

105°C products: AEC-Q200 Grade2 (已在Grade2的测试条件下评价完毕。)

85°C products: AEC-Q200 Grade3 (已在Grade3的测试条件下评价完毕。)

关于本产品的详细规格和评估测试结果等信息，请咨询正规销售渠道。

此外，订购时请索取产品规格书，就其内容进行确认并批准之。

- *1: 关于寸规格，请参照型号标示法的外型尺寸、产品厚度、产品尺寸公差、以及标准产品的尺寸。

车载(车身系 / 情报系)用途 多层陶瓷电容器 (高介电常数)

●0603规格

【温度特性 B7 : X7R (-55~+125°C)】 0.3mm厚度

新型号	旧型号(参考用)	额定电压 [V]	温度特性	静电容量 [F]	静电容量允许偏差 [%]	tan δ [%]	高温负载		厚度*1 [mm]	注释
							额定电压 x %			
MCAST063SB7101 [] FCA01	TMKO63 B7101 [] PHFE	25	X7R	100 p	±10, ±20	3.5	200		0.3±0.03	
MCAST063SB7151 [] FCA01	TMKO63 B7151 [] PHFE	25	X7R	150 p	±10, ±20	3.5	200		0.3±0.03	
MCAST063SB7221 [] FCA01	TMKO63 B7221 [] PHFE	25	X7R	220 p	±10, ±20	3.5	200		0.3±0.03	
MCAST063SB7331 [] FCA01	TMKO63 B7331 [] PHFE	25	X7R	330 p	±10, ±20	3.5	200		0.3±0.03	
MCAST063SB7471 [] FCA01	TMKO63 B7471 [] PHFE	25	X7R	470 p	±10, ±20	3.5	200		0.3±0.03	
MCAST063SB7102 [] FCA01	TMKO63 B7102 [] PHFE	25	X7R	1000 p	±10, ±20	3.5	200		0.3±0.03	
MCAST063SB7152 [] FCA01	TMKO63 B7152 [] PHFE	25	X7R	1500 p	±10, ±20	5	200		0.3±0.03	
MCAST063SB7222 [] FCA01	TMKO63 B7222 [] PHFE	25	X7R	2200 p	±10, ±20	5	200		0.3±0.03	
MCAST063SB7332 [] FCA01	TMKO63 B7332 [] PHFE	25	X7R	3300 p	±10, ±20	5	200		0.3±0.03	
MCASE063SB7101 [] FCA01	EMKO63 B7101 [] PHFE	16	X7R	100 p	±10, ±20	3.5	200		0.3±0.03	
MCASE063SB7151 [] FCA01	EMKO63 B7151 [] PHFE	16	X7R	150 p	±10, ±20	3.5	200		0.3±0.03	
MCASE063SB7221 [] FCA01	EMKO63 B7221 [] PHFE	16	X7R	220 p	±10, ±20	3.5	200		0.3±0.03	
MCASE063SB7331 [] FCA01	EMKO63 B7331 [] PHFE	16	X7R	330 p	±10, ±20	3.5	200		0.3±0.03	
MCASE063SB7471 [] FCA01	EMKO63 B7471 [] PHFE	16	X7R	470 p	±10, ±20	3.5	200		0.3±0.03	
MCASE063SB7102 [] FCA01	EMKO63 B7102 [] PHFE	16	X7R	1000 p	±10, ±20	3.5	200		0.3±0.03	
MCASE063SB7152 [] FCA01	EMKO63 B7152 [] PHFE	16	X7R	1500 p	±10, ±20	5	200		0.3±0.03	
MCASE063SB7222 [] FCA01	EMKO63 B7222 [] PHFE	16	X7R	2200 p	±10, ±20	5	200		0.3±0.03	
MCASE063SB7332 [] FCA01	EMKO63 B7332 [] PHFE	16	X7R	3300 p	±10, ±20	5	200		0.3±0.03	
MCASL063SB7101 [] FCA01	LMKO63 B7101 [] PHFE	10	X7R	100 p	±10, ±20	3.5	200		0.3±0.03	
MCASL063SB7151 [] FCA01	LMKO63 B7151 [] PHFE	10	X7R	150 p	±10, ±20	3.5	200		0.3±0.03	
MCASL063SB7221 [] FCA01	LMKO63 B7221 [] PHFE	10	X7R	220 p	±10, ±20	3.5	200		0.3±0.03	
MCASL063SB7331 [] FCA01	LMKO63 B7331 [] PHFE	10	X7R	330 p	±10, ±20	3.5	200		0.3±0.03	
MCASL063SB7471 [] FCA01	LMKO63 B7471 [] PHFE	10	X7R	470 p	±10, ±20	3.5	200		0.3±0.03	
MCASL063SB7102 [] FCA01	LMKO63 B7102 [] PHFE	10	X7R	1000 p	±10, ±20	3.5	200		0.3±0.03	
MCASL063SB7152 [] FCA01	LMKO63 B7152 [] PHFE	10	X7R	1500 p	±10, ±20	5	200		0.3±0.03	
MCASL063SB7222 [] FCA01	LMKO63 B7222 [] PHFE	10	X7R	2200 p	±10, ±20	5	200		0.3±0.03	
MCASL063SB7332 [] FCA01	LMKO63 B7332 [] PHFE	10	X7R	3300 p	±10, ±20	5	200		0.3±0.03	
MCASL063SB7472 [] FCA01	LMKO63 B7472 [] PHFE	10	X7R	4700 p	±10, ±20	5	200		0.3±0.03	
MCASL063SB7682 [] FCA01	LMKO63 B7682 [] PHFE	10	X7R	6800 p	±10, ±20	5	200		0.3±0.03	
MCASL063SB7103 [] FCA01	LMKO63 B7103 [] PHFE	10	X7R	0.01 μ	±10, ±20	5	200		0.3±0.03	
MCASJ063SD7104 [] FCA01	JMKO63 D7104 [] PHFE	6.3	X7R	0.1 μ	±10, ±20	10	200		0.3±0.03	

▶ 由于篇幅有限，本产品目录中只记载了有代表性的产品规格，若考虑使用敝公司产品时，请确认交货规格说明书中的详细规格。另外，有关各产品的详细信息(特性图、可靠性信息、使用时的注意事项等)，请参阅敝公司网站(<http://www.ty-top.com/>)。

■型号一览

●1005规格

【温度特性 B5 (BJ) : X5R (-55~+85°C)】 0.5mm厚度

新型号	旧型号(参考用)	额定电压 [V]	温度特性	静电容量 [F]	静电容量允许偏差 [%]	tan δ [%]	高温负载		厚度*1 [mm]	注释
							额定电压 x %			
MCASU105SB5471 FNA01	UMK105 BJ471 VHF	50	X5R	470 p	±10, ±20	2.5	200	0.5±0.05		
MCASU105SB5102 FNA01	UMK105 BJ102 VHF	50	X5R	1000 p	±10, ±20	2.5	200	0.5±0.05		
MCASU105SB5152 FNA01	UMK105 BJ152 VHF	50	X5R	1500 p	±10, ±20	2.5	200	0.5±0.05		
MCASU105SB5222 FNA01	UMK105 BJ222 VHF	50	X5R	2200 p	±10, ±20	2.5	200	0.5±0.05		
MCASU105SB5332 FNA01	UMK105 BJ332 VHF	50	X5R	3300 p	±10, ±20	2.5	200	0.5±0.05		
MCASU105SB5472 FNA01	UMK105 BJ472 VHF	50	X5R	4700 p	±10, ±20	2.5	200	0.5±0.05		
MCASU105SB5682 FNA01	UMK105 BJ682 VHF	50	X5R	6800 p	±10, ±20	2.5	150	0.5±0.05		
MCASU105SB5103 FNA01	UMK105 BJ103 VHF	50	X5R	0.01 μ	±10, ±20	3.5	200	0.5±0.05		
MCASU105SB5223 FNA01	UMK105 BJ223 VHF	50	X5R	0.022 μ	±10, ±20	5	200	0.5±0.05		
MCASU105SB5473 FNA01	UMK105 BJ473 VHF	50	X5R	0.047 μ	±10, ±20	5	200	0.5±0.05		
MCASU105SB5104 FNA01	UMK105 BJ104 VHF	50	X5R	0.1 μ	±10, ±20	10	150	0.5±0.05		
MCAST105SB5472 FNA01	TMK105 BJ472 VHF	25	X5R	4700 p	±10, ±20	2.5	200	0.5±0.05		
MCAST105SB5682 FNA01	TMK105 BJ682 VHF	25	X5R	6800 p	±10, ±20	2.5	200	0.5±0.05		
MCAST105SB5103 FNA01	TMK105 BJ103 VHF	25	X5R	0.01 μ	±10, ±20	3.5	200	0.5±0.05		
MCAST105SB5153 FNA01	TMK105 BJ153 VHF	25	X5R	0.015 μ	±10, ±20	3.5	200	0.5±0.05		
MCAST105SB5223 FNA01	TMK105 BJ223 VHF	25	X5R	0.022 μ	±10, ±20	3.5	200	0.5±0.05		
MCAST105SB5333 FNA01	TMK105 BJ333 VHF	25	X5R	0.033 μ	±10, ±20	3.5	150	0.5±0.05		
MCAST105SB5473 FNA01	TMK105 BJ473 VHF	25	X5R	0.047 μ	±10, ±20	3.5	150	0.5±0.05		
MCAST105SB5104 FNA01	TMK105 BJ104 VHF	25	X5R	0.1 μ	±10, ±20	5	150	0.5±0.05		
MCAST105SB5224 FNA01	TMK105 BJ224 VHF	25	X5R	0.22 μ	±10, ±20	10	150	0.5±0.05		
MCAST105AB5474 FNA01	TMK105ABJ474 VHF	25	X5R	0.47 μ	±10, ±20	10	150	0.5±0.10		
MCASE105SB5103 FNA01	EMK105 BJ103 VHF	16	X5R	0.01 μ	±10, ±20	3.5	200	0.5±0.05		
MCASE105SB5153 FNA01	EMK105 BJ153 VHF	16	X5R	0.015 μ	±10, ±20	3.5	200	0.5±0.05		
MCASE105SB5223 FNA01	EMK105 BJ223 VHF	16	X5R	0.022 μ	±10, ±20	3.5	200	0.5±0.05		
MCASE105SB5333 FNA01	EMK105 BJ333 VHF	16	X5R	0.033 μ	±10, ±20	3.5	150	0.5±0.05		
MCASE105SB5473 FNA01	EMK105 BJ473 VHF	16	X5R	0.047 μ	±10, ±20	3.5	150	0.5±0.05		
MCASE105SB5104 FNA01	EMK105 BJ104 VHF	16	X5R	0.1 μ	±10, ±20	5	150	0.5±0.05		
MCASE105SB5224 FNA01	EMK105 BJ224 VHF	16	X5R	0.22 μ	±10, ±20	10	150	0.5±0.05		
MCASE105AB5474 FNA01	EMK105ABJ474 VHF	16	X5R	0.47 μ	±10, ±20	10	150	0.5±0.10		
MCASE105SB5105 FNA01	EMK105 BJ105 VHF	16	X5R	1 μ	±10, ±20	10	150	0.5±0.05		
MCASL105SB5333 FNA01	LMK105 BJ333 VHF	10	X5R	0.033 μ	±10, ±20	3.5	150	0.5±0.05		
MCASL105SB5473 FNA01	LMK105 BJ473 VHF	10	X5R	0.047 μ	±10, ±20	3.5	150	0.5±0.05		
MCASL105SB5104 FNA01	LMK105 BJ104 VHF	10	X5R	0.1 μ	±10, ±20	5	150	0.5±0.05		
MCASL105SB5224 FNA01	LMK105 BJ224 VHF	10	X5R	0.22 μ	±10, ±20	5	150	0.5±0.05		
MCASL105AB5474 FNA01	LMK105ABJ474 VHF	10	X5R	0.47 μ	±10, ±20	10	150	0.5±0.10		
MCASL105SB5105 FNA01	LMK105 BJ105 VHF	10	X5R	1 μ	±10, ±20	10	150	0.5±0.05		
MCASL105AB5225 FNA01	LMK105ABJ225 VHF	10	X5R	2.2 μ	±10, ±20	10	150	0.5±0.10		
MCASJ105SB5104 FNA01	JMK105 BJ104 VHF	6.3	X5R	0.1 μ	±10, ±20	5	150	0.5±0.05		
MCASJ105SB5224 FNA01	JMK105 BJ224 VHF	6.3	X5R	0.22 μ	±10, ±20	5	150	0.5±0.05		
MCASJ105SB5474 FNA01	JMK105 BJ474 VHF	6.3	X5R	0.47 μ	±10, ±20	10	150	0.5±0.05		
MCASJ105SB5105 FNA01	JMK105 BJ105 VHF	6.3	X5R	1 μ	±10, ±20	10	150	0.5±0.05		
MCASJ105SB5225 FNA01	JMK105 BJ225 VHF	6.3	X5R	2.2 μ	±10, ±20	10	150	0.5±0.05		
MCASJ105BB5475MVFNA01	JMK105BBJ475MVF	6.3	X5R	4.7 μ	±20	10	150	0.5+0.15/-0.05		
MCASA105SB5225 FNA01	AMK105 BJ225 VHF	4	X5R	2.2 μ	±10, ±20	10	150	0.5±0.05		
MCASA105BB5475MVFNA01	AMK105BBJ475MVF	4	X5R	4.7 μ	±20	10	150	0.5+0.15/-0.05		

【温度特性 C6 : X6S (-55~+105°C)】 0.5mm厚度

新型号	旧型号(参考用)	额定电压 [V]	温度特性	静电容量 [F]	静电容量允许偏差 [%]	tan δ [%]	高温负载		厚度*1 [mm]	注释
							额定电压 x %			
MCASE105AC6474 FNA01	EMK105AC6474 VHF	16	X6S	0.47 μ	±10, ±20	10	150	0.5±0.10		
MCASL105SC6105 FNA01	LMK105 C6105 VHF	10	X6S	1 μ	±10, ±20	10	150	0.5±0.05		
MCASJ105SC6105 FNA01	JMK105 C6105 VHF	6.3	X6S	1 μ	±10, ±20	10	150	0.5±0.05		

▶ 由于篇幅有限, 本产品目录中只记载了有代表性的产品规格, 若考虑使用敝公司产品时, 请确认交货规格说明书中的详细规格。
另外, 有关各产品的详细信息(特性图、可靠性信息、使用时的注意事项等), 请参阅敝公司网站(<http://www.ty-top.com/>)。

■型号一览

【温度特性 B7 : X7R (-55~+125°C), D7 : X7T (-55~+125°C)】 0.5mm厚度

新型号	旧型号(参考用)	额定电压 [V]	温度特性	静电容量 [F]	静电容量允许偏差 [%]	tan δ [%]	高温负载		厚度*1 [mm]	注释
							额定电压 x %			
MCASU105SB7221 [] FNA01	UMK105 B7221 [] VHF	50	X7R	220 p	±10, ±20	2.5	200		0.5±0.05	
MCASU105SB7331 [] FNA01	UMK105 B7331 [] VHF	50	X7R	330 p	±10, ±20	2.5	200		0.5±0.05	
MCASU105SB7471 [] FNA01	UMK105 B7471 [] VHF	50	X7R	470 p	±10, ±20	2.5	200		0.5±0.05	
MCASU105SB7681 [] FNA01	UMK105 B7681 [] VHF	50	X7R	680 p	±10, ±20	2.5	200		0.5±0.05	
MCASU105SB7102 [] FNA01	UMK105 B7102 [] VHF	50	X7R	1000 p	±10, ±20	2.5	200		0.5±0.05	
MCASU105SB7152 [] FNA01	UMK105 B7152 [] VHF	50	X7R	1500 p	±10, ±20	2.5	200		0.5±0.05	
MCASU105SB7222 [] FNA01	UMK105 B7222 [] VHF	50	X7R	2200 p	±10, ±20	2.5	200		0.5±0.05	
MCASU105SB7332 [] FNA01	UMK105 B7332 [] VHF	50	X7R	3300 p	±10, ±20	2.5	200		0.5±0.05	
MCASU105SB7472 [] FNA01	UMK105 B7472 [] VHF	50	X7R	4700 p	±10, ±20	2.5	150		0.5±0.05	
MCASU105SB7682 [] FNA01	UMK105 B7682 [] VHF	50	X7R	6800 p	±10, ±20	2.5	150		0.5±0.05	
MCASU105SB7103 [] FNA01	UMK105 B7103 [] VHF	50	X7R	0.01 μ	±10, ±20	3.5	150		0.5±0.05	
MCASU105SB7153 [] FCA01	UMK105 B7153 [] VHFE	50	X7R	0.015 μ	±10, ±20	3.5	200		0.5±0.05	
MCASU105SB7223 [] FNA01	UMK105 B7223 [] VHF	50	X7R	0.022 μ	±10, ±20	10	200		0.5±0.05	
MCASU105SB7333 [] FCA01	UMK105 B7333 [] VHFE	50	X7R	0.033 μ	±10, ±20	3.5	150		0.5±0.05	
MCASU105SB7473 [] FNA01	UMK105 B7473 [] VHF	50	X7R	0.047 μ	±10, ±20	10	200		0.5±0.05	
MCASU105SB7104 [] FNA01	UMK105 B7104 [] VHF	50	X7R	0.1 μ	±10, ±20	10	150		0.5±0.05	
MCASU105SB7472 [] FNA01	TMK105 B7472 [] VHF	25	X7R	4700 p	±10, ±20	2.5	200		0.5±0.05	
MCASU105SB7682 [] FNA01	TMK105 B7682 [] VHF	25	X7R	6800 p	±10, ±20	2.5	200		0.5±0.05	
MCASU105SB7103 [] FNA01	TMK105 B7103 [] VHF	25	X7R	0.01 μ	±10, ±20	3.5	200		0.5±0.05	
MCASU105SB7153 [] FNA01	TMK105 B7153 [] VHF	25	X7R	0.015 μ	±10, ±20	3.5	150		0.5±0.05	
MCASU105SB7223 [] FNA01	TMK105 B7223 [] VHF	25	X7R	0.022 μ	±10, ±20	3.5	150		0.5±0.05	
MCASU105SB7333 [] FNA01	TMK105 B7333 [] VHF	25	X7R	0.033 μ	±10, ±20	3.5	150		0.5±0.05	
MCASU105SB7473 [] FNA01	TMK105 B7473 [] VHF	25	X7R	0.047 μ	±10, ±20	3.5	150		0.5±0.05	
MCASU105SB7104 [] FNA01	TMK105 B7104 [] VHF	25	X7R	0.1 μ	±10, ±20	10	150		0.5±0.05	
MCASE105SB7103 [] FNA01	EMK105 B7103 [] VHF	16	X7R	0.01 μ	±10, ±20	3.5	200		0.5±0.05	
MCASE105SB7153 [] FNA01	EMK105 B7153 [] VHF	16	X7R	0.015 μ	±10, ±20	3.5	150		0.5±0.05	
MCASE105SB7223 [] FNA01	EMK105 B7223 [] VHF	16	X7R	0.022 μ	±10, ±20	3.5	150		0.5±0.05	
MCASE105SB7333 [] FNA01	EMK105 B7333 [] VHF	16	X7R	0.033 μ	±10, ±20	3.5	150		0.5±0.05	
MCASE105SB7473 [] FNA01	EMK105 B7473 [] VHF	16	X7R	0.047 μ	±10, ±20	3.5	150		0.5±0.05	
MCASE105SB7104 [] FNA01	EMK105 B7104 [] VHF	16	X7R	0.1 μ	±10, ±20	5	150		0.5±0.05	
MCASE105SB7224 [] FNA01	EMK105 B7224 [] VHF	16	X7R	0.22 μ	±10, ±20	10	150		0.5±0.05	
MCASL105SB7473 [] FNA01	LMK105 B7473 [] VHF	10	X7R	0.047 μ	±10, ±20	3.5	150		0.5±0.05	
MCASL105SB7104 [] FNA01	LMK105 B7104 [] VHF	10	X7R	0.1 μ	±10, ±20	5	150		0.5±0.05	
MCASL105SB7224 [] FNA01	LMK105 B7224 [] VHF	10	X7R	0.22 μ	±10, ±20	10	150		0.5±0.05	
MCASL105AD7474 [] FCA01	LMK105AD7474 [] VHFE	10	X7R	0.47 μ	±10, ±20	10	150		0.5±0.10	
MCASL105CD7105 [] FCA01	LMK105CD7105 [] VHFE	10	X7R	1 μ	±10, ±20	10	150		0.5+0.20/-0	
MCASJ105SB7104 [] FNA01	JMK105 B7104 [] VHF	6.3	X7R	0.1 μ	±10, ±20	5	150		0.5±0.05	
MCASJ105SB7224 [] FNA01	JMK105 B7224 [] VHF	6.3	X7R	0.22 μ	±10, ±20	10	150		0.5±0.05	
MCASJ105SB7474 [] FNA01	JMK105 B7474 [] VHF	6.3	X7R	0.47 μ	±10, ±20	10	150		0.5±0.05	
MCASJ105CD7105 [] FNA01	JMK105CD7105 [] VHF	6.3	X7T	1 μ	±10, ±20	10	150		0.5+0.20/-0	
MCASA105SB7474 [] FNA01	AMK105 B7474 [] VHF	4	X7R	0.47 μ	±10, ±20	10	150		0.5±0.05	

●1608规格

【温度特性 B5 (BJ) : X5R (-55~+85°C)】 0.8mm厚度

新型号	旧型号(参考用)	额定电压 [V]	温度特性	静电容量 [F]	静电容量允许偏差 [%]	tan δ [%]	高温负载		厚度*1 [mm]	注释
							额定电压 x %			
MCASU168SB5104 [] TNA01	UMK107 BJ104 [] AHT	50	X5R	0.1 μ	±10, ±20	3.5	150		0.8±0.10	
MCASU168SB5224 [] TNA01	UMK107 BJ224 [] AHT	50	X5R	0.22 μ	±10, ±20	10	150		0.8±0.10	
MCASU168SB5474 [] TNA01	UMK107 BJ474 [] AHT	50	X5R	0.47 μ	±10, ±20	10	150		0.8±0.10	
MCASU168AB5105 [] TNA01	UMK107ABJ105 [] AHT	50	X5R	1 μ	±10, ±20	10	150		0.8+0.15/-0.05	
MCASG168SB5223 [] TNA01	GMK107 BJ223 [] AHT	35	X5R	0.022 μ	±10, ±20	2.5	200		0.8±0.10	
MCASG168SB5473 [] TNA01	GMK107 BJ473 [] AHT	35	X5R	0.047 μ	±10, ±20	3.5	200		0.8±0.10	
MCASG168SB5104 [] TNA01	GMK107 BJ104 [] AHT	35	X5R	0.1 μ	±10, ±20	3.5	150		0.8±0.10	
MCASG168SB5224 [] TNA01	GMK107 BJ224 [] AHT	35	X5R	0.22 μ	±10, ±20	10	150		0.8±0.10	
MCASG168AB5474 [] TNA01	GMK107ABJ474 [] AHT	35	X5R	0.47 μ	±10, ±20	10	150		0.8+0.15/-0.05	
MCASG168SB5105 [] TNA01	GMK107 BJ105 [] AHT	35	X5R	1 μ	±10, ±20	10	150		0.8±0.10	
MCASU168SB5223 [] TNA01	TMK107 BJ223 [] AHT	25	X5R	0.022 μ	±10, ±20	2.5	200		0.8±0.10	
MCASU168SB5473 [] TNA01	TMK107 BJ473 [] AHT	25	X5R	0.047 μ	±10, ±20	3.5	200		0.8±0.10	
MCASU168SB5104 [] TNA01	TMK107 BJ104 [] AHT	25	X5R	0.1 μ	±10, ±20	3.5	150		0.8±0.10	
MCASU168SB5224 [] TNA01	TMK107 BJ224 [] AHT	25	X5R	0.22 μ	±10, ±20	5	150		0.8±0.10	
MCASU168SB5474 [] TNA01	TMK107 BJ474 [] AHT	25	X5R	0.47 μ	±10, ±20	3.5	150		0.8±0.10	
MCASU168SB5105 [] TNA01	TMK107 BJ105 [] AHT	25	X5R	1 μ	±10, ±20	10	150		0.8±0.10	
MCASU168BB5225 [] TNA01	TMK107BBJ225 [] AHT	25	X5R	2.2 μ	±10, ±20	10	150		0.8+0.20/-0	
MCASE168SB5104 [] TNA01	EMK107 BJ104 [] AHT	16	X5R	0.1 μ	±10, ±20	3.5	150		0.8±0.10	
MCASE168SB5224 [] TNA01	EMK107 BJ224 [] AHT	16	X5R	0.22 μ	±10, ±20	5	150		0.8±0.10	
MCASE168SB5474 [] TNA01	EMK107 BJ474 [] AHT	16	X5R	0.47 μ	±10, ±20	3.5	150		0.8±0.10	
MCASE168SB5105 [] TNA01	EMK107 BJ105 [] AHT	16	X5R	1 μ	±10, ±20	5	150		0.8±0.10	
MCASE168AB5225 [] TNA01	EMK107ABJ225 [] AHT	16	X5R	2.2 μ	±10, ±20	10	150		0.8+0.15/-0.05	
MCASE168BB5475 [] TNA01	EMK107BBJ475 [] AHT	16	X5R	4.7 μ	±10, ±20	10	150		0.8+0.20/-0	
MCASL168SB5474 [] TNA01	LMK107 BJ474 [] AHT	10	X5R	0.47 μ	±10, ±20	3.5	150		0.8±0.10	
MCASL168SB5105 [] TNA01	LMK107 BJ105 [] AHT	10	X5R	1 μ	±10, ±20	5	150		0.8±0.10	
MCASL168SB5225 [] TNA01	LMK107 BJ225 [] AHT	10	X5R	2.2 μ	±10, ±20	10	150		0.8±0.10	
MCASL168SB5475 [] TNA01	LMK107 BJ475 [] AHT	10	X5R	4.7 μ	±10, ±20	10	150		0.8±0.10	
MCASL168BB5106MNTA01	LMK107BBJ106MHAHT	10	X5R	10 μ	±20	10	150		0.8+0.20/-0	
MCASJ168SB5105 [] TNA01	JMK107 BJ105 [] AHT	6.3	X5R	1 μ	±10, ±20	5	150		0.8±0.10	
MCASJ168SB5225 [] TNA01	JMK107 BJ225 [] AHT	6.3	X5R	2.2 μ	±10, ±20	10	150		0.8±0.10	
MCASJ168SB5475 [] TNA01	JMK107 BJ475 [] AHT	6.3	X5R	4.7 μ	±10, ±20	10	150		0.8±0.10	
MCASJ168AB5106 [] TNA01	JMK107ABJ106 [] AHT	6.3	X5R	10 μ	±10, ±20	10	150		0.8+0.15/-0.05	
MCASA168AB5106 [] TNA01	AMK107ABJ106 [] AHT	4	X5R	10 μ	±10, ±20	10	150		0.8+0.15/-0.05	
MCASA168BB5226MNTA01	AMK107BBJ226MHAHT	4	X5R	22 μ	±20	10	150		0.8+0.20/-0	

▶ 由于篇幅有限, 本产品目录中只记载了有代表性的产品规格, 若考虑使用敝公司产品时, 请确认交货规格说明书中的详细规格。另外, 有关各产品的详细信息(特性图、可靠性信息、使用时的注意事项等), 请参阅敝公司网站(http://www.ty-top.com/)。

●型号一览

【温度特性 G6 : X6S (-55~+105°C)】 0.8mm厚度

新型号	旧型号(参考用)	额定电压 [V]	温度特性	静电容量 [F]	静电容量允许偏差 [%]	tan δ [%]	高温负载		厚度*1 [mm]	注释
							额定电压 x %			
MCASL168SC6225 □ TNA01	LMK107 C6225 □ AHT	10	X6S	2.2 μ	±10, ±20	10	150		0.8±0.10	
MCASJ168AC6475 □ TNA01	JMK107AC6475 □ AHT	6.3	X6S	4.7 μ	±10, ±20	10	150		0.8+0.15/-0.05	
MCASJ168BC6106MTNA01	JMK107BC6106MAHT	6.3	X6S	10 μ	±20	10	150		0.8+0.20/-0	

【温度特性 B7 : X7R (-55~+125°C), C7 : X7S (-55~+125°C), D7 : X7T (-55~+125°C)】 0.8mm厚度

新型号	旧型号(参考用)	额定电压 [V]	温度特性	静电容量 [F]	静电容量允许偏差 [%]	tan δ [%]	高温负载		厚度*1 [mm]	注释
							额定电压 x %			
MCASU168SB7102 □ TNA01	UMK107 B7102 □ AHT	50	X7R	1000 p	±10, ±20	3.5	200		0.8±0.10	
MCASU168SB7152 □ TNA01	UMK107 B7152 □ AHT	50	X7R	1500 p	±10, ±20	3.5	200		0.8±0.10	
MCASU168SB7222 □ TNA01	UMK107 B7222 □ AHT	50	X7R	2200 p	±10, ±20	3.5	200		0.8±0.10	
MCASU168SB7332 □ TNA01	UMK107 B7332 □ AHT	50	X7R	3300 p	±10, ±20	3.5	200		0.8±0.10	
MCASU168SB7472 □ TNA01	UMK107 B7472 □ AHT	50	X7R	4700 p	±10, ±20	3.5	200		0.8±0.10	
MCASU168SB7682 □ TNA01	UMK107 B7682 □ AHT	50	X7R	6800 p	±10, ±20	3.5	200		0.8±0.10	
MCASU168SB7103 □ TNA01	UMK107 B7103 □ AHT	50	X7R	0.01 μ	±10, ±20	3.5	200		0.8±0.10	
MCASU168SB7153 □ TNA01	UMK107 B7153 □ AHT	50	X7R	0.015 μ	±10, ±20	3.5	200		0.8±0.10	
MCASU168SB7223 □ TNA01	UMK107 B7223 □ AHT	50	X7R	0.022 μ	±10, ±20	3.5	200		0.8±0.10	
MCASU168SB7333 □ TNA01	UMK107 B7333 □ AHT	50	X7R	0.033 μ	±10, ±20	3.5	200		0.8±0.10	
MCASU168SB7473 □ TNA01	UMK107 B7473 □ AHT	50	X7R	0.047 μ	±10, ±20	3.5	200		0.8±0.10	
MCASU168SB7683 □ TNA01	UMK107 B7683 □ AHT	50	X7R	0.068 μ	±10, ±20	3.5	150		0.8±0.10	
MCASU168SB7104 □ TNA01	UMK107 B7104 □ AHT	50	X7R	0.1 μ	±10, ±20	3.5	200		0.8±0.10	
MCASU168AC7154 □ TCA01	UMK107AC7154 □ AHT	50	X7S	0.15 μ	±10, ±20	3.5	150		0.8+0.15/-0.05	
MCASU168SC7224 □ TCA01	UMK107 C7224 □ AHT	50	X7S	0.22 μ	±10, ±20	3.5	150		0.8±0.10	
MCASU168SB7474 □ TCA01	UMK107 B7474 □ AHT	50	X7R	0.47 μ	±10, ±20	10	150		0.8±0.10	
MCASG168SB7473 □ TNA01	GMK107 B7473 □ AHT	35	X7R	0.047 μ	±10, ±20	3.5	200		0.8±0.10	
MCASG168SB7104 □ TNA01	GMK107 B7104 □ AHT	35	X7R	0.1 μ	±10, ±20	3.5	150		0.8±0.10	
MCASG168SB7224 □ TNA01	GMK107 B7224 □ AHT	35	X7R	0.22 μ	±10, ±20	10	150		0.8±0.10	
MCASG168SB7474 □ TNA01	GMK107 B7474 □ AHT	35	X7R	0.47 μ	±10, ±20	10	150		0.8±0.10	
MCASG168AB7105 □ TNA01	GMK107AB7105 □ AHT	35	X7R	1 μ	±10, ±20	10	150		0.8+0.15/-0.05	
MCASU168SB7223 □ TNA01	TMK107 B7223 □ AHT	25	X7R	0.022 μ	±10, ±20	2.5	200		0.8±0.10	
MCASU168SB7473 □ TNA01	TMK107 B7473 □ AHT	25	X7R	0.047 μ	±10, ±20	3.5	200		0.8±0.10	
MCASU168SB7104 □ TNA01	TMK107 B7104 □ AHT	25	X7R	0.1 μ	±10, ±20	3.5	150		0.8±0.10	
MCASU168SB7224 □ TNA01	TMK107 B7224 □ AHT	25	X7R	0.22 μ	±10, ±20	10	150		0.8±0.10	
MCASU168SB7474 □ TNA01	TMK107 B7474 □ AHT	25	X7R	0.47 μ	±10, ±20	10	150		0.8±0.10	
MCASU168AB7105 □ TNA01	TMK107AB7105 □ AHT	25	X7R	1 μ	±10, ±20	10	150		0.8+0.15/-0.05	
MCASE168SB7473 □ TNA01	EMK107 B7473 □ AHT	16	X7R	0.047 μ	±10, ±20	3.5	200		0.8±0.10	
MCASE168SB7104 □ TNA01	EMK107 B7104 □ AHT	16	X7R	0.1 μ	±10, ±20	3.5	150		0.8±0.10	
MCASE168SB7224 □ TNA01	EMK107 B7224 □ AHT	16	X7R	0.22 μ	±10, ±20	5	150		0.8±0.10	
MCASE168SB7474 □ TNA01	EMK107 B7474 □ AHT	16	X7R	0.47 μ	±10, ±20	10	150		0.8±0.10	
MCASE168SB7105 □ TNA01	EMK107 B7105 □ AHT	16	X7R	1 μ	±10, ±20	10	150		0.8±0.10	
MCASL168SB7224 □ TNA01	LMK107 B7224 □ AHT	10	X7R	0.22 μ	±10, ±20	5	150		0.8±0.10	
MCASL168SB7474 □ TNA01	LMK107 B7474 □ AHT	10	X7R	0.47 μ	±10, ±20	3.5	150		0.8±0.10	
MCASL168SB7105 □ TNA01	LMK107 B7105 □ AHT	10	X7R	1 μ	±10, ±20	10	150		0.8±0.10	
MCASL168BD7225 □ TNA01	LMK107BD7225 □ AHT	10	X7T	2.2 μ	±10, ±20	10	200		0.8+0.20/-0	
MCASJ168SB7105 □ TNA01	JMK107 B7105 □ AHT	6.3	X7R	1 μ	±10, ±20	10	150		0.8±0.10	
MCASJ168SB7225 □ TNB25	JMK107 B7225 □ AHTR	6.3	X7R	2.2 μ	±10, ±20	10	150		0.8±0.10	

●2012规格

【温度特性 B5 (BJ) : X5R (-55~+85°C)】 1.25mm厚度

新型号	旧型号(参考用)	额定电压 [V]	温度特性	静电容量 [F]	静电容量允许偏差 [%]	tan δ [%]	高温负载		厚度*1 [mm]	注释
							额定电压 x %			
MCASU21GSB5104 □ TNA01	UMK212 BJ104 □ GHT	50	X5R	0.1 μ	±10, ±20	3.5	200		1.25±0.10	
MCASU21GSB5224 □ TNA01	UMK212 BJ224 □ GHT	50	X5R	0.22 μ	±10, ±20	3.5	200		1.25±0.10	
MCASU21GSB5474 □ TNA01	UMK212 BJ474 □ GHT	50	X5R	0.47 μ	±10, ±20	3.5	150		1.25±0.10	
MCASU21GSB5105 □ TNA01	UMK212 BJ105 □ GHT	50	X5R	1 μ	±10, ±20	5	150		1.25±0.10	
MCASG21GSB5104 □ TNA01	GMK212 BJ104 □ GHT	35	X5R	0.1 μ	±10, ±20	3.5	200		1.25±0.10	
MCASG21GSB5224 □ TNA01	GMK212 BJ224 □ GHT	35	X5R	0.22 μ	±10, ±20	3.5	150		1.25±0.10	
MCASG21GSB5474 □ TNA01	GMK212 BJ474 □ GHT	35	X5R	0.47 μ	±10, ±20	3.5	150		1.25±0.10	
MCASG21GSB5105 □ TNA01	GMK212 BJ105 □ GHT	35	X5R	1 μ	±10, ±20	5	150		1.25±0.10	
MCASG21GBB5225 □ TNA01	GMK212BBJ225 □ GHT	35	X5R	2.2 μ	±10, ±20	10	150		1.25+0.20/-0	
MCASU21GSB5104 □ TNA01	TMK212 BJ104 □ GHT	25	X5R	0.1 μ	±10, ±20	3.5	200		1.25±0.10	
MCASU21GSB5224 □ TNA01	TMK212 BJ224 □ GHT	25	X5R	0.22 μ	±10, ±20	3.5	150		1.25±0.10	
MCASU21GSB5474 □ TNA01	TMK212 BJ474 □ GHT	25	X5R	0.47 μ	±10, ±20	3.5	200		1.25±0.10	
MCASU21GSB5105 □ TNA01	TMK212 BJ105 □ GHT	25	X5R	1 μ	±10, ±20	3.5	150		1.25±0.10	
MCASU21GSB5225 □ TNA01	TMK212 BJ225 □ GHT	25	X5R	2.2 μ	±10, ±20	5	150		1.25±0.10	
MCASU21GBB5475 □ TNA01	TMK212BBJ475 □ GHT	25	X5R	4.7 μ	±10, ±20	10	150		1.25+0.20/-0	
MCASU21GBB5106 □ TNA01	TMK212BBJ106 □ GHT	25	X5R	10 μ	±10, ±20	10	150		1.25+0.20/-0	
MCASE21GSB5105 □ TNA01	EMK212 BJ105 □ GHT	16	X5R	1 μ	±10, ±20	3.5	150		1.25±0.10	
MCASE21GSB5225 □ TNA01	EMK212 BJ225 □ GHT	16	X5R	2.2 μ	±10, ±20	5	150		1.25±0.10	
MCASE21GAB5475 □ TNA01	EMK212ABJ475 □ GHT	16	X5R	4.7 μ	±10, ±20	10	150		1.25+0.15/-0.05	
MCASE21GBB5106 □ TNA01	EMK212BBJ106 □ GHT	16	X5R	10 μ	±10, ±20	10	150		1.25+0.20/-0	
MCASL21GSB5225 □ TNA01	LMK212 BJ225 □ GHT	10	X5R	2.2 μ	±10, ±20	5	200		1.25±0.10	
MCASL21GAB5475 □ TNA01	LMK212ABJ475 □ GHT	10	X5R	4.7 μ	±10, ±20	10	150		1.25+0.15/-0.05	
MCASL21GAB5106 □ TNA01	LMK212ABJ106 □ GHT	10	X5R	10 μ	±10, ±20	10	150		1.25+0.15/-0.05	
MCASJ21GAB5475 □ TNA01	JMK212ABJ475 □ GHT	6.3	X5R	4.7 μ	±10, ±20	5	200		1.25+0.15/-0.05	
MCASJ21GAB5106 □ TNA01	JMK212ABJ106 □ GHT	6.3	X5R	10 μ	±10, ±20	10	150		1.25+0.15/-0.05	
MCASJ21GBB5226MTNA01	JMK212BBJ226MGHT	6.3	X5R	22 μ	±20	10	150		1.25+0.20/-0	
MCASA21GAB5226MTNA01	AMK212ABJ226MGHT	4	X5R	22 μ	±20	10	150		1.25+0.15/-0.05	
MCASA21GBB5476MTNA01	AMK212BBJ476MGHT	4	X5R	47 μ	±20	10	150		1.25+0.20/-0	

▶ 由于篇幅有限, 本产品目录中只记载了有代表性的产品规格, 若考虑使用敝公司产品时, 请确认交货规格说明书中的详细规格。另外, 有关各产品的详细信息(特性图、可靠性信息、使用时的注意事项等), 请参阅敝公司网站(<http://www.ty-top.com/>)。

■型号一览

【温度特性 B5 (BJ) : X5R (-55~+85°C)】 0.85mm厚度

新型号	旧型号(参考用)	额定电压 [V]	温度特性	静电容量 [F]	静电容量允许偏差 [%]	tan δ [%]	高温负载	厚度*1 [mm]	注释
							额定电压 x %		
MCASE219SB5105 [TNA01]	EMK212 BJ105 [DHT]	16	X5R	1 μ	±10, ±20	5	200	0.85±0.10	
MCASE219JB5225 [TNA01]	EMK212ABJ225 [DHT]	16	X5R	2.2 μ	±10, ±20	5	150	0.85±0.10	
MCASE219LB5475 [TNA01]	EMK212BBJ475 [DHT]	16	X5R	4.7 μ	±10, ±20	10	150	0.85±0.10	

【温度特性 G6 : X6S (-55~+105°C)】 1.25mm厚度

新型号	旧型号(参考用)	额定电压 [V]	温度特性	静电容量 [F]	静电容量允许偏差 [%]	tan δ [%]	高温负载	厚度*1 [mm]	注释
							额定电压 x %		
MCASL21GBC6106 [TNA01]	LMK212BC6106 [GHT]	10	X6S	10 μ	±10, ±20	10	150	1.25+0.20/-0	
MCASA21GBC6226MTNA01	AMK212BC6226MGHT	4	X6S	22 μ	±20	10	150	1.25+0.20/-0	

【温度特性 B7 : X7R (-55~+125°C), G7 : X7S (-55~+125°C)】 1.25mm厚度

新型号	旧型号(参考用)	额定电压 [V]	温度特性	静电容量 [F]	静电容量允许偏差 [%]	tan δ [%]	高温负载	厚度*1 [mm]	注释
							额定电压 x %		
MCASU21GSB7103 [TNA01]	UMK212 B7103 [GHT]	50	X7R	0.01 μ	±10, ±20	3.5	200	1.25±0.10	
MCASU21GSB7153 [TNA01]	UMK212 B7153 [GHT]	50	X7R	0.015 μ	±10, ±20	2.5	200	1.25±0.10	
MCASU21GSB7223 [TNA01]	UMK212 B7223 [GHT]	50	X7R	0.022 μ	±10, ±20	3.5	200	1.25±0.10	
MCASU21GSB7333 [TNA01]	UMK212 B7333 [GHT]	50	X7R	0.033 μ	±10, ±20	3.5	200	1.25±0.10	
MCASU21GSB7473 [TNA01]	UMK212 B7473 [GHT]	50	X7R	0.047 μ	±10, ±20	3.5	200	1.25±0.10	
MCASU21GSB7683 [TNA01]	UMK212 B7683 [GHT]	50	X7R	0.068 μ	±10, ±20	3.5	200	1.25±0.10	
MCASU21GSB7104 [TNA01]	UMK212 B7104 [GHT]	50	X7R	0.1 μ	±10, ±20	3.5	200	1.25±0.10	
MCASU21GBB7154 [TCA01]	UMK212BB7154 [GHTE]	50	X7R	0.15 μ	±10, ±20	3.5	200	1.25+0.2/-0	
MCASU21GSB7224 [TNA01]	UMK212 B7224 [GHT]	50	X7R	0.22 μ	±10, ±20	3.5	150	1.25±0.10	
MCASU21GBC7334 [TCA01]	UMK212BC7334 [GHTE]	50	X7S	0.33 μ	±10, ±20	3.5	150	1.25+0.2/-0	
MCASU21GSC7474 [TCA01]	UMK212 C7474 [GHTE]	50	X7S	0.47 μ	±10, ±20	3.5	150	1.25±0.10	
MCASU21GCC7684 [TCA01]	UMK212CC7684 [GHTE]	50	X7S	0.68 μ	±10, ±20	3.5	150	1.25+0.25/-0	
MCASU21GSB7105 [TNA01]	UMK212 B7105 [GHT]	50	X7R	1 μ	±10, ±20	10	150	1.25±0.10	
MCASG21GSB7224 [TNA01]	GMK212 B7224 [GHT]	35	X7R	0.22 μ	±10, ±20	3.5	150	1.25±0.10	
MCASG21GSB7105 [TNA01]	GMK212 B7105 [GHT]	35	X7R	1 μ	±10, ±20	10	150	1.25±0.10	
MCAS21GSB7224 [TNA01]	TMK212 B7224 [GHT]	25	X7R	0.22 μ	±10, ±20	3.5	150	1.25±0.10	
MCAS21GSB7334 [TNA01]	TMK212 B7334 [GHT]	25	X7R	0.33 μ	±10, ±20	3.5	200	1.25±0.10	
MCAS21GSB7474 [TNA01]	TMK212 B7474 [GHT]	25	X7R	0.47 μ	±10, ±20	3.5	150	1.25±0.10	
MCAS21GSB7105 [TNB25]	TMK212 B7105 [GHTR]	25	X7R	1 μ	±10, ±20	10	150	1.25±0.10	
MCAS21GSB7225 [TNA01]	TMK212 B7225 [GHT]	25	X7R	2.2 μ	±10, ±20	10	150	1.25±0.10	
MCASE21GSB7224 [TNA01]	EMK212 B7224 [GHT]	16	X7R	0.22 μ	±10, ±20	3.5	200	1.25±0.10	
MCASE21GSB7334 [TNA01]	EMK212 B7334 [GHT]	16	X7R	0.33 μ	±10, ±20	3.5	200	1.25±0.10	
MCASE21GSB7474 [TNA01]	EMK212 B7474 [GHT]	16	X7R	0.47 μ	±10, ±20	3.5	200	1.25±0.10	
MCASE21GSB7105 [TNB25]	EMK212 B7105 [GHTR]	16	X7R	1 μ	±10, ±20	10	150	1.25±0.10	
MCASE21GSB7225 [TNA01]	EMK212 B7225 [GHT]	16	X7R	2.2 μ	±10, ±20	10	150	1.25±0.10	
MCASE21GAB7475 [TNA01]	EMK212AB7475 [GHT]	16	X7R	4.7 μ	±10, ±20	10	150	1.25+0.15/-0.05	
MCASL21GSB7105 [TNB25]	LMK212 B7105 [GHTR]	10	X7R	1 μ	±10, ±20	10	150	1.25±0.10	
MCASL21GSB7225 [TNA01]	LMK212 B7225 [GHT]	10	X7R	2.2 μ	±10, ±20	10	150	1.25±0.10	
MCASL21GSB7475 [TNA01]	LMK212 B7475 [GHT]	10	X7R	4.7 μ	±10, ±20	10	150	1.25±0.10	
MCASL21GBB7106 [TNA01]	LMK212BB7106 [GHT]	10	X7R	10 μ	±10, ±20	10	150	1.25+0.2/-0	
MCASJ21GSB7475 [TNA01]	JMK212 B7475 [GHT]	6.3	X7R	4.7 μ	±10, ±20	10	150	1.25±0.10	
MCASJ21GAB7106 [TNA01]	JMK212AB7106 [GHT]	6.3	X7R	10 μ	±10, ±20	10	150	1.25+0.15/-0.05	

●3216规格

【温度特性 B5 (BJ) : X5R (-55~+85°C)】 1.6mm厚度

新型号	旧型号(参考用)	额定电压 [V]	温度特性	静电容量 [F]	静电容量允许偏差 [%]	tan δ [%]	高温负载	厚度*1 [mm]	注释
							额定电压 x %		
MCASU31LSB5474 [TNA01]	UMK316 BJ474 [LHT]	50	X5R	0.47 μ	±10, ±20	3.5	200	1.6±0.20	
MCASU31LSB5105 [TNA01]	UMK316 BJ105 [LHT]	50	X5R	1 μ	±10, ±20	3.5	200	1.6±0.20	
MCASU31LSB5225 [TNA01]	UMK316 BJ225 [LHT]	50	X5R	2.2 μ	±10, ±20	10	150	1.6±0.20	
MCASU31LAB5475 [TNA01]	UMK316ABJ475 [LHT]	50	X5R	4.7 μ	±10, ±20	10	150	1.6±0.20	
MCASG31LSB5105 [TNA01]	GMK316 BJ105 [LHT]	35	X5R	1 μ	±10, ±20	3.5	200	1.6±0.20	
MCASG31LSB5225 [TNA01]	GMK316 BJ225 [LHT]	35	X5R	2.2 μ	±10, ±20	10	150	1.6±0.20	
MCASG31LSB5475 [TNA01]	GMK316 BJ475 [LHT]	35	X5R	4.7 μ	±10, ±20	10	150	1.6±0.20	
MCASG31LBB5106 [TNA01]	GMK316BBJ106 [LHT]	35	X5R	10 μ	±10, ±20	10	150	1.6±0.30	
MCAS21LSB5225 [TNA01]	TMK316 BJ225 [LHT]	25	X5R	2.2 μ	±10, ±20	3.5	200	1.6±0.20	
MCAS21LSB5475 [TNA01]	TMK316 BJ475 [LHT]	25	X5R	4.7 μ	±10, ±20	5	150	1.6±0.20	
MCAS21LSB5106 [TNA01]	TMK316 BJ106 [LHT]	25	X5R	10 μ	±10, ±20	5	150	1.6±0.20	
MCASE31LSB5225 [TNA01]	EMK316 BJ225 [LHT]	16	X5R	2.2 μ	±10, ±20	3.5	200	1.6±0.20	
MCASE31LSB5475 [TNA01]	EMK316 BJ475 [LHT]	16	X5R	4.7 μ	±10, ±20	5	150	1.6±0.20	
MCASE31LSB5106 [TNA01]	EMK316 BJ106 [LHT]	16	X5R	10 μ	±10, ±20	5	150	1.6±0.20	
MCASE31LBB5226MTNA01	EMK316BBJ226MLHT	16	X5R	22 μ	±20	10	150	1.6±0.30	
MCASL31LSB5475 [TNA01]	LMK316 BJ475 [LHT]	10	X5R	4.7 μ	±10, ±20	5	150	1.6±0.20	
MCASL31LSB5106 [TNA01]	LMK316 BJ106 [LHT]	10	X5R	10 μ	±10, ±20	5	150	1.6±0.20	
MCASL31LAB5226 [TNA01]	LMK316ABJ226 [LHT]	10	X5R	22 μ	±10, ±20	10	150	1.6±0.20	
MCASJ31LSB5106 [TNA01]	JMK316 BJ106 [LHT]	6.3	X5R	10 μ	±10, ±20	5	200	1.6±0.20	
MCASJ31LAB5226 [TNA01]	JMK316ABJ226 [LHT]	6.3	X5R	22 μ	±10, ±20	10	150	1.6±0.20	
MCASJ31LAB5476MTNA01	JMK316ABJ476MLHT	6.3	X5R	47 μ	±20	10	150	1.6±0.20	

▶由于篇幅有限,本产品目录中只记载了有代表性的产品规格,若考虑使用敝公司产品时,请确认交货规格说明书中的详细规格。另外,有关各产品的详细信息(特性图、可靠性信息、使用时的注意事项等),请参阅敝公司网站(http://www.ty-top.com/)。

■ 型号一览

【温度特性 B7 : X7R (-55~+125°C), C7 : X7S (-55~+125°C)】 1.6mm厚度

新型号	旧型号(参考用)	额定电压 [V]	温度特性	静电容量 [F]	静电容量允许偏差[%]	tan δ [%]	高温负载		厚度*1 [mm]	注释
							额定电压 x %			
MCASU31LSB7473 □ TNA01	UMK316 B7473 □ LHT	50	X7R	0.047 μ	±10, ±20	3.5	200		1.6±0.20	
MCASU31LSB7683 □ TNA01	UMK316 B7683 □ LHT	50	X7R	0.068 μ	±10, ±20	2.5	200		1.6±0.20	
MCASU31LSB7104 □ TNA01	UMK316 B7104 □ LHT	50	X7R	0.1 μ	±10, ±20	3.5	200		1.6±0.20	
MCASU31LSB7154 □ TNA01	UMK316 B7154 □ LHT	50	X7R	0.15 μ	±10, ±20	3.5	200		1.6±0.20	
MCASU31LSB7224 □ TNA01	UMK316 B7224 □ LHT	50	X7R	0.22 μ	±10, ±20	3.5	200		1.6±0.20	
MCASU31LSB7334 □ TNA01	UMK316 B7334 □ LHT	50	X7R	0.33 μ	±10, ±20	3.5	200		1.6±0.20	
MCASU31LSB7474 □ TNA01	UMK316 B7474 □ LHT	50	X7R	0.47 μ	±10, ±20	3.5	200		1.6±0.20	
MCASU31LSB7105 □ TNA01	UMK316 B7105 □ LHT	50	X7R	1 μ	±10, ±20	3.5	200		1.6±0.20	
MCASU31LBC7155 □ TGA01	UMK316BC7155 □ LHTE	50	X7S	1.5 μ	±10, ±20	3.5	150		1.6±0.30	
MCASU31LSB7225 □ TNA01	UMK316 B7225 □ LHT	50	X7R	2.2 μ	±10, ±20	10	150		1.6±0.20	
MCASU31LAC7475 □ TGA01	UMK316AC7475 □ LHTE	50	X7S	4.7 μ	±10, ±20	2.5	150		1.6±0.20	
MCASG31LSB7105 □ TNA01	GMK316 B7105 □ LHT	35	X7R	1 μ	±10, ±20	3.5	200		1.6±0.20	
MCASG31LSB7225 □ TNA01	GMK316 B7225 □ LHT	35	X7R	2.2 μ	±10, ±20	10	150		1.6±0.20	
MCASG31LAB7475 □ TNA01	GMK316AB7475 □ LHT	35	X7R	4.7 μ	±10, ±20	10	150		1.6±0.20	
MCASG31LSB7105 □ TNA01	TMK316 B7105 □ LHT	25	X7R	1 μ	±10, ±20	3.5	200		1.6±0.20	
MCASG31LSB7225 □ TNA01	TMK316 B7225 □ LHT	25	X7R	2.2 μ	±10, ±20	3.5	200		1.6±0.20	
MCASG31LAB7475 □ TNA01	TMK316AB7475 □ LHT	25	X7R	4.7 μ	±10, ±20	10	150		1.6±0.20	
MCASG31LSB7106 □ TNA01	TMK316AB7106 □ LHT	25	X7R	10 μ	±10, ±20	10	150		1.6±0.20	
MCASE31LSB7225 □ TNA01	EMK316 B7225 □ LHT	16	X7R	2.2 μ	±10, ±20	3.5	200		1.6±0.20	
MCASE31LAB7475 □ TNA01	EMK316AB7475 □ LHT	16	X7R	4.7 μ	±10, ±20	10	150		1.6±0.20	
MCASE31LAB7106 □ TNA01	EMK316AB7106 □ LHT	16	X7R	10 μ	±10, ±20	10	150		1.6±0.20	
MCASL31LSB7475 □ TNA01	LMK316 B7475 □ LHT	10	X7R	4.7 μ	±10, ±20	5	150		1.6±0.20	
MCASL31LAB7106 □ TNA01	LMK316AB7106 □ LHT	10	X7R	10 μ	±10, ±20	10	150		1.6±0.20	
MCASJ31LAB7106 □ TNA01	JMK316AB7106 □ LHT	6.3	X7R	10 μ	±10, ±20	10	150		1.6±0.20	
MCASJ31LAB7226 □ TNA01	JMK316AB7226 □ LHT	6.3	X7R	22 μ	±10, ±20	10	150		1.6±0.20	
MCASA31LAB7226 □ TNA01	AMK316AB7226 □ LHT	4	X7R	22 μ	±10, ±20	10	150		1.6±0.20	
MCASA31LAC7476MTNA01	AMK316AC7476MLHT	4	X7S	47 μ	±20	10	150		1.6±0.20	

● 3225规格

【温度特性 B5 (BJ) : X5R (-55~+85°C)】 2.5mm厚度

新型号	旧型号(参考用)	额定电压 [V]	温度特性	静电容量 [F]	静电容量允许偏差[%]	tan δ [%]	高温负载		厚度*1 [mm]	注释
							额定电压 x %			
MCASU32MSB5106 □ PNA01	UMK325 BJ106 □ MHP	50	X5R	10 μ	±10, ±20	5	150		2.5±0.20	
MCASG32MSB5106 □ PNA01	GMK325 BJ106 □ MHP	35	X5R	10 μ	±10, ±20	5	150		2.5±0.20	
MCASG32MSB5106 □ PNA01	TMK325 BJ106 □ MHP	25	X5R	10 μ	±10, ±20	5	150		2.5±0.20	
MCASE32MSB5226 □ PNA01	EMK325 BJ226 □ MHP	16	X5R	22 μ	±10, ±20	5	150		2.5±0.20	
MCASE32MAB5476 □ PNDT1	EMK325ABJ476 □ MHP	16	X5R	47 μ	±10, ±20	10	150		2.5±0.30	
MCASL32MSB5226 □ PNA01	LMK325 BJ226 □ MHP	10	X5R	22 μ	±10, ±20	5	150		2.5±0.20	
MCASL32MAB5476 □ PNA01	LMK325 BJ476 □ MHP	10	X5R	47 μ	±10, ±20	10	150		2.5±0.20	
MCASJ32MSB5476 □ PNA01	JMK325 BJ476 □ MHP	6.3	X5R	47 μ	±10, ±20	10	150		2.5±0.20	

【温度特性 B5 (BJ) : X5R (-55~+85°C)】 1.9mm厚度

新型号	旧型号(参考用)	额定电压 [V]	温度特性	静电容量 [F]	静电容量允许偏差[%]	tan δ [%]	高温负载		厚度*1 [mm]	注释
							额定电压 x %			
MCASU32NSB5475 □ TNA01	UMK325 BJ475 □ NHT	50	X5R	4.7 μ	±10, ±20	10	150		1.9±0.20	
MCASG32NSB5225MTNA01	GMK325 BJ225MNHT	35	X5R	2.2 μ	±20	3.5	200		1.9±0.20	
MCASG32NSB5475 □ TNA01	GMK325 BJ475 □ NHT	35	X5R	4.7 μ	±10, ±20	10	150		1.9±0.20	
MCASG32NSB5475 □ TNA01	TMK325 BJ475 □ NHT	25	X5R	4.7 μ	±10, ±20	10	150		1.9±0.20	
MCASE32NSB5475MTNA01	EMK325 BJ475MNHT	16	X5R	4.7 μ	±20	3.5	200		1.9±0.20	
MCASE32NSB5106 □ TNA01	EMK325 BJ106 □ NHT	16	X5R	10 μ	±10, ±20	5	150		1.9±0.20	

【温度特性 B7 : X7R (-55~+125°C)】 2.5mm厚度

新型号	旧型号(参考用)	额定电压 [V]	温度特性	静电容量 [F]	静电容量允许偏差[%]	tan δ [%]	高温负载		厚度*1 [mm]	注释
							额定电压 x %			
MCASU32MSB7225 □ PNA01	UMK325 B7225 □ MHP	50	X7R	2.2 μ	±10, ±20	3.5	200		2.5±0.20	
MCASU32MSB7335 □ PNA01	UMK325 B7335 □ MHP	50	X7R	3.3 μ	±10, ±20	3.5	200		2.5±0.20	
MCASU32MSB7475 □ PNA01	UMK325 B7475 □ MHP	50	X7R	4.7 μ	±10, ±20	5	150		2.5±0.20	
MCASU32MAB7106 □ PNA01	UMK325AB7106 □ MHP	50	X7R	10 μ	±10, ±20	10	150		2.5±0.30	
MCASG32MAB7106 □ PNA01	GMK325AB7106 □ MHP	35	X7R	10 μ	±10, ±20	10	150		2.5±0.30	
MCASG32MSB7335 □ PNA01	TMK325 B7335 □ MHP	25	X7R	3.3 μ	±10, ±20	3.5	200		2.5±0.20	
MCASG32MAB7106 □ PNB25	TMK325AB7106 □ MHP	25	X7R	10 μ	±10, ±20	10	150		2.5±0.30	
MCASG32MSB7226 □ PNA01	TMK325 B7226 □ MHP	25	X7R	22 μ	±10, ±20	10	150		2.5±0.20	
MCASE32MSB7226 □ PNA01	EMK325 B7226 □ MHP	16	X7R	22 μ	±10, ±20	10	150		2.5±0.20	
MCASL32MSB7226 □ PNA01	LMK325 B7226 □ MHP	10	X7R	22 μ	±10, ±20	10	150		2.5±0.20	
MCASJ32MSB7226 □ PNB25	JMK325 B7226 □ MHP	6.3	X7R	22 μ	±10, ±20	10	150		2.5±0.20	
MCASJ32MSB7476 □ PNB25	JMK325 B7476 □ MHP	6.3	X7R	47 μ	±10, ±20	10	150		2.5±0.20	

【温度特性 B7 : X7R (-55~+125°C)】 1.9mm厚度

新型号	旧型号(参考用)	额定电压 [V]	温度特性	静电容量 [F]	静电容量允许偏差[%]	tan δ [%]	高温负载		厚度*1 [mm]	注释
							额定电压 x %			
MCASU32NSB7105 □ TNA01	UMK325 B7105 □ NHT	50	X7R	1 μ	±10, ±20	3.5	200		1.9±0.20	
MCASG32NSB7225 □ TNA01	GMK325 B7225 □ NHT	35	X7R	2.2 μ	±10, ±20	3.5	200		1.9±0.20	
MCASG32NSB7475 □ TNB25	GMK325 B7475 □ NHT	35	X7R	4.7 μ	±10, ±20	10	150		1.9±0.20	
MCASG32NSB7475 □ TNA01	TMK325 B7475 □ NHT	25	X7R	4.7 μ	±10, ±20	10	150		1.9±0.20	
MCASE32NSB7475 □ TNA01	EMK325 B7475 □ NHT	16	X7R	4.7 μ	±10, ±20	3.5	150		1.9±0.20	
MCASE32NSB7106 □ TNB25	EMK325 B7106 □ NHT	16	X7R	10 μ	±10, ±20	10	150		1.9±0.20	

▶ 由于篇幅有限, 本产品目录中只记载了有代表性的产品规格, 若考虑使用敝公司产品时, 请确认交货规格说明书中的详细规格。另外, 有关各产品的详细信息(特性图、可靠性信息、使用时的注意事项等), 请参阅敝公司网站(<http://www.ty-top.com/>)。

车载(车身分/情报系)用途 多层陶瓷电容器(温度补偿用)

●0603规格

【温度特性 $C\Delta$: $C\Delta/CO\Delta$ (-55~+125°C)】 0.3mm厚度

新型号	旧型号(参考用)	额定电压 [V]	温度特性		静电容量 [F]	静电容量允许偏差	Q值 [at 1MHz] (Min)	高温负载	厚度*1 [mm]	注释
								额定电压 x %		
MCASU063SCK0R5CFNA01	UMKO63 CK0R5CTHF	50	CK	COK	0.5 p	±0.25pF	410	200	0.3±0.03	
MCASU063SCK010CFNA01	UMKO63 CK010CTHF	50	CK	COK	1 p	±0.25pF	420	200	0.3±0.03	
MCASU063SCK1R5CFNA01	UMKO63 CK1R5CTHF	50	CK	COK	1.5 p	±0.25pF	430	200	0.3±0.03	
MCASU063SCK20CFNA01	UMKO63 CK20CTHF	50	CK	COK	2 p	±0.25pF	440	200	0.3±0.03	
MCASU063SCJ030CFNA01	UMKO63 CJ030CTHF	50	CJ	COJ	3 p	±0.25pF	460	200	0.3±0.03	
MCASU063SCH040CFNA01	UMKO63 CH040CTHF	50	CH	COH	4 p	±0.25pF	480	200	0.3±0.03	
MCASU063SCH050CFNA01	UMKO63 CH050CTHF	50	CH	COH	5 p	±0.25pF	500	200	0.3±0.03	
MCASU063SCH060DFNA01	UMKO63 CH060DTHF	50	CH	COH	6 p	±0.5pF	520	200	0.3±0.03	
MCASU063SCH070DFNA01	UMKO63 CH070DTHF	50	CH	COH	7 p	±0.5pF	540	200	0.3±0.03	
MCASU063SCH080DFNA01	UMKO63 CH080DTHF	50	CH	COH	8 p	±0.5pF	560	200	0.3±0.03	
MCASU063SCH090DFNA01	UMKO63 CH090DTHF	50	CH	COH	9 p	±0.5pF	580	200	0.3±0.03	
MCASU063SCH100DFNA01	UMKO63 CH100DTHF	50	CH	COH	10 p	±0.5pF	600	200	0.3±0.03	
MCASU063SCH120JFNA01	UMKO63 CH120JTHF	50	CH	COH	12 p	±5%	640	200	0.3±0.03	
MCASU063SCH150JFNA01	UMKO63 CH150JTHF	50	CH	COH	15 p	±5%	700	200	0.3±0.03	
MCASU063SCH180JFNA01	UMKO63 CH180JTHF	50	CH	COH	18 p	±5%	760	200	0.3±0.03	
MCASU063SCH220JFNA01	UMKO63 CH220JTHF	50	CH	COH	22 p	±5%	840	200	0.3±0.03	
MCASU063SCH270JFNA01	UMKO63 CH270JTHF	50	CH	COH	27 p	±5%	940	200	0.3±0.03	
MCASU063SCH330JFNA01	UMKO63 CH330JTHF	50	CH	COH	33 p	±5%	1000	200	0.3±0.03	
MCASU063SCH390JFNA01	UMKO63 CH390JTHF	50	CH	COH	39 p	±5%	1000	200	0.3±0.03	
MCASU063SCH470JFNA01	UMKO63 CH470JTHF	50	CH	COH	47 p	±5%	1000	200	0.3±0.03	
MCASU063SCH560JFNA01	UMKO63 CH560JTHF	50	CH	COH	56 p	±5%	1000	200	0.3±0.03	
MCASU063SCH680JFNA01	UMKO63 CH680JTHF	50	CH	COH	68 p	±5%	1000	200	0.3±0.03	
MCASU063SCH820JFNA01	UMKO63 CH820JTHF	50	CH	COH	82 p	±5%	1000	200	0.3±0.03	
MCASU063SCH101JFNA01	UMKO63 CH101JTHF	50	CH	COH	100 p	±5%	1000	200	0.3±0.03	
MCASU063SCH121JFNA01	UMKO63 CH121JTHF	50	CH	COH	120 p	±5%	1000	200	0.3±0.03	
MCASU063SCH151JFNA01	UMKO63 CH151JTHF	50	CH	COH	150 p	±5%	1000	200	0.3±0.03	
MCASU063SCH181JFNA01	UMKO63 CH181JTHF	50	CH	COH	180 p	±5%	1000	200	0.3±0.03	
MCASU063SCH221JFNA01	UMKO63 CH221JTHF	50	CH	COH	220 p	±5%	1000	200	0.3±0.03	
MCASU063SCH121JFNA01	TMKO63 CH121JTHF	25	CH	COH	120 p	±5%	1000	200	0.3±0.03	
MCASU063SCH151JFNA01	TMKO63 CH151JTHF	25	CH	COH	150 p	±5%	1000	200	0.3±0.03	
MCASU063SCH181JFNA01	TMKO63 CH181JTHF	25	CH	COH	180 p	±5%	1000	200	0.3±0.03	
MCASU063SCH221JFNA01	TMKO63 CH221JTHF	25	CH	COH	220 p	±5%	1000	200	0.3±0.03	
MCASU063SCG0R5CFNA01	UMKO63 CG0R5CTHF	50	CG	COG	0.5 p	±0.25pF	410	200	0.3±0.03	
MCASU063SCG010CFNA01	UMKO63 CG010CTHF	50	CG	COG	1 p	±0.25pF	420	200	0.3±0.03	
MCASU063SCG1R5CFNA01	UMKO63 CG1R5CTHF	50	CG	COG	1.5 p	±0.25pF	430	200	0.3±0.03	
MCASU063SCG20CFNA01	UMKO63 CG20CTHF	50	CG	COG	2 p	±0.25pF	440	200	0.3±0.03	
MCASU063SCG030CFNA01	UMKO63 CG030CTHF	50	CG	COG	3 p	±0.25pF	460	200	0.3±0.03	
MCASU063SCG040CFNA01	UMKO63 CG040CTHF	50	CG	COG	4 p	±0.25pF	480	200	0.3±0.03	
MCASU063SCG050CFNA01	UMKO63 CG050CTHF	50	CG	COG	5 p	±0.25pF	500	200	0.3±0.03	
MCASU063SCG060DFNA01	UMKO63 CG060DTHF	50	CG	COG	6 p	±0.5pF	520	200	0.3±0.03	
MCASU063SCG070DFNA01	UMKO63 CG070DTHF	50	CG	COG	7 p	±0.5pF	540	200	0.3±0.03	
MCASU063SCG080DFNA01	UMKO63 CG080DTHF	50	CG	COG	8 p	±0.5pF	560	200	0.3±0.03	
MCASU063SCG090DFNA01	UMKO63 CG090DTHF	50	CG	COG	9 p	±0.5pF	580	200	0.3±0.03	
MCASU063SCG100DFNA01	UMKO63 CG100DTHF	50	CG	COG	10 p	±0.5pF	600	200	0.3±0.03	
MCASU063SCG120JFNA01	UMKO63 CG120JTHF	50	CG	COG	12 p	±5%	640	200	0.3±0.03	
MCASU063SCG150JFNA01	UMKO63 CG150JTHF	50	CG	COG	15 p	±5%	700	200	0.3±0.03	
MCASU063SCG180JFNA01	UMKO63 CG180JTHF	50	CG	COG	18 p	±5%	760	200	0.3±0.03	
MCASU063SCG220JFNA01	UMKO63 CG220JTHF	50	CG	COG	22 p	±5%	840	200	0.3±0.03	
MCASU063SCG270JFNA01	UMKO63 CG270JTHF	50	CG	COG	27 p	±5%	940	200	0.3±0.03	
MCASU063SCG330JFNA01	UMKO63 CG330JTHF	50	CG	COG	33 p	±5%	1000	200	0.3±0.03	
MCASU063SCG390JFNA01	UMKO63 CG390JTHF	50	CG	COG	39 p	±5%	1000	200	0.3±0.03	
MCASU063SCG470JFNA01	UMKO63 CG470JTHF	50	CG	COG	47 p	±5%	1000	200	0.3±0.03	
MCASU063SCG560JFNA01	UMKO63 CG560JTHF	50	CG	COG	56 p	±5%	1000	200	0.3±0.03	
MCASU063SCG680JFNA01	UMKO63 CG680JTHF	50	CG	COG	68 p	±5%	1000	200	0.3±0.03	
MCASU063SCG820JFNA01	UMKO63 CG820JTHF	50	CG	COG	82 p	±5%	1000	200	0.3±0.03	
MCASU063SCG101JFNA01	UMKO63 CG101JTHF	50	CG	COG	100 p	±5%	1000	200	0.3±0.03	
MCASU063SCG121JFNA01	UMKO63 CG121JTHF	50	CG	COG	120 p	±5%	1000	200	0.3±0.03	
MCASU063SCG151JFNA01	UMKO63 CG151JTHF	50	CG	COG	150 p	±5%	1000	200	0.3±0.03	
MCASU063SCG181JFNA01	UMKO63 CG181JTHF	50	CG	COG	180 p	±5%	1000	200	0.3±0.03	
MCASU063SCG221JFNA01	UMKO63 CG221JTHF	50	CG	COG	220 p	±5%	1000	200	0.3±0.03	
MCASU063SCG121JFNA01	TMKO63 CG121JTHF	25	CG	COG	120 p	±5%	1000	200	0.3±0.03	
MCASU063SCG151JFNA01	TMKO63 CG151JTHF	25	CG	COG	150 p	±5%	1000	200	0.3±0.03	
MCASU063SCG181JFNA01	TMKO63 CG181JTHF	25	CG	COG	180 p	±5%	1000	200	0.3±0.03	
MCASU063SCG221JFNA01	TMKO63 CG221JTHF	25	CG	COG	220 p	±5%	1000	200	0.3±0.03	

▶ 由于篇幅有限, 本产品目录中只记载了有代表性的产品规格, 若考虑使用敝公司产品时, 请确认交货规格说明书中的详细规格。另外, 有关各产品的详细信息(特性图、可靠性信息、使用时的注意事项等), 请参阅敝公司网站(<http://www.ty-top.com/>)。

■ 型号一览

● 1005规格

【温度特性 C△ : C△/C0△ (-55~+125°C)】 0.5mm厚度

新型号	旧型号(参考用)	额定电压 [V]	温度特性		静电容量 [F]	静电容量允许偏差	Q值 [at 1MHz] (Min)	高温负载		厚度*1 [mm]	注释
								额定电压 x %			
MCASU1055CK0R5CFNA01	UMK105 CK0R5CVHF	50	GK	COK	0.5 p	±0.25pF	410	200		0.5±0.05	
MCASU1055CK010CFNA01	UMK105 CK010CVHF	50	GK	COK	1 p	±0.25pF	420	200		0.5±0.05	
MCASU1055CK1R5CFNA01	UMK105 CK1R5CVHF	50	GK	COK	1.5 p	±0.25pF	430	200		0.5±0.05	
MCASU1055CK020CFNA01	UMK105 CK020CVHF	50	GK	COK	2 p	±0.25pF	440	200		0.5±0.05	
MCASU1055CJ030CFNA01	UMK105 CJ030CVHF	50	GJ	COJ	3 p	±0.25pF	460	200		0.5±0.05	
MCASU1055CH040CFNA01	UMK105 CH040CVHF	50	GH	COH	4 p	±0.25pF	480	200		0.5±0.05	
MCASU1055CH050CFNA01	UMK105 CH050CVHF	50	GH	COH	5 p	±0.25pF	500	200		0.5±0.05	
MCASU1055CH060DFNA01	UMK105 CH060DVHF	50	GH	COH	6 p	±0.5pF	520	200		0.5±0.05	
MCASU1055CH070DFNA01	UMK105 CH070DVHF	50	GH	COH	7 p	±0.5pF	540	200		0.5±0.05	
MCASU1055CH080DFNA01	UMK105 CH080DVHF	50	GH	COH	8 p	±0.5pF	560	200		0.5±0.05	
MCASU1055CH090DFNA01	UMK105 CH090DVHF	50	GH	COH	9 p	±0.5pF	580	200		0.5±0.05	
MCASU1055CH100DFNA01	UMK105 CH100DVHF	50	GH	COH	10 p	±0.5pF	600	200		0.5±0.05	
MCASU1055CH120JFNA01	UMK105 CH120JVHF	50	GH	COH	12 p	±5%	640	200		0.5±0.05	
MCASU1055CH150JFNA01	UMK105 CH150JVHF	50	GH	COH	15 p	±5%	700	200		0.5±0.05	
MCASU1055CH180JFNA01	UMK105 CH180JVHF	50	GH	COH	18 p	±5%	760	200		0.5±0.05	
MCASU1055CH220JFNA01	UMK105 CH220JVHF	50	GH	COH	22 p	±5%	840	200		0.5±0.05	
MCASU1055CH270JFNA01	UMK105 CH270JVHF	50	GH	COH	27 p	±5%	940	200		0.5±0.05	
MCASU1055CH330JFNA01	UMK105 CH330JVHF	50	GH	COH	33 p	±5%	1000	200		0.5±0.05	
MCASU1055CH390JFNA01	UMK105 CH390JVHF	50	GH	COH	39 p	±5%	1000	200		0.5±0.05	
MCASU1055CH470JFNA01	UMK105 CH470JVHF	50	GH	COH	47 p	±5%	1000	200		0.5±0.05	
MCASU1055CH560JFNA01	UMK105 CH560JVHF	50	GH	COH	56 p	±5%	1000	200		0.5±0.05	
MCASU1055CH680JFNA01	UMK105 CH680JVHF	50	GH	COH	68 p	±5%	1000	200		0.5±0.05	
MCASU1055CH820JFNA01	UMK105 CH820JVHF	50	GH	COH	82 p	±5%	1000	200		0.5±0.05	
MCASU1055CH101JFNA01	UMK105 CH101JVHF	50	GH	COH	100 p	±5%	1000	200		0.5±0.05	
MCASU1055CH121JFNA01	UMK105 CH121JVHF	50	GH	COH	120 p	±5%	1000	200		0.5±0.05	
MCASU1055CH151JFNA01	UMK105 CH151JVHF	50	GH	COH	150 p	±5%	1000	200		0.5±0.05	
MCASU1055CH181JFNA01	UMK105 CH181JVHF	50	GH	COH	180 p	±5%	1000	200		0.5±0.05	
MCASU1055CH221JFNA01	UMK105 CH221JVHF	50	GH	COH	220 p	±5%	1000	200		0.5±0.05	
MCASU1055CH271JFNA01	UMK105 CH271JVHF	50	GH	COH	270 p	±5%	1000	200		0.5±0.05	
MCASU1055CH331JFNA01	UMK105 CH331JVHF	50	GH	COH	330 p	±5%	1000	200		0.5±0.05	
MCASU1055CH391JFNA01	UMK105 CH391JVHF	50	GH	COH	390 p	±5%	1000	200		0.5±0.05	
MCASU1055CH471JFNA01	UMK105 CH471JVHF	50	GH	COH	470 p	±5%	1000	200		0.5±0.05	
MCASU1055CH561JFNA01	UMK105 CH561JVHF	50	GH	COH	560 p	±5%	1000	200		0.5±0.05	
MCASU1055CH681JFNA01	UMK105 CH681JVHF	50	GH	COH	680 p	±5%	1000	200		0.5±0.05	
MCASU1055CH821JFNA01	UMK105 CH821JVHF	50	GH	COH	820 p	±5%	1000	200		0.5±0.05	
MCASU1055CH102JFNA01	UMK105 CH102JVHF	50	GH	COH	1000 p	±5%	1000	200		0.5±0.05	
MCASU1055CG0R5CFNA01	UMK105 CG0R5CVHF	50	GG	COG	0.5 p	±0.25pF	410	200		0.5±0.05	
MCASU1055CG010CFNA01	UMK105 CG010CVHF	50	GG	COG	1 p	±0.25pF	420	200		0.5±0.05	
MCASU1055CG1R5CFNA01	UMK105 CG1R5CVHF	50	GG	COG	1.5 p	±0.25pF	430	200		0.5±0.05	
MCASU1055CG020CFNA01	UMK105 CG020CVHF	50	GG	COG	2 p	±0.25pF	440	200		0.5±0.05	
MCASU1055CG030CFNA01	UMK105 CG030CVHF	50	GG	COG	3 p	±0.25pF	460	200		0.5±0.05	
MCASU1055CG040CFNA01	UMK105 CG040CVHF	50	GG	COG	4 p	±0.25pF	480	200		0.5±0.05	
MCASU1055CG050CFNA01	UMK105 CG050CVHF	50	GG	COG	5 p	±0.25pF	500	200		0.5±0.05	
MCASU1055CG060DFNA01	UMK105 CG060DVHF	50	GG	COG	6 p	±0.5pF	520	200		0.5±0.05	
MCASU1055CG070DFNA01	UMK105 CG070DVHF	50	GG	COG	7 p	±0.5pF	540	200		0.5±0.05	
MCASU1055CG080DFNA01	UMK105 CG080DVHF	50	GG	COG	8 p	±0.5pF	560	200		0.5±0.05	
MCASU1055CG090DFNA01	UMK105 CG090DVHF	50	GG	COG	9 p	±0.5pF	580	200		0.5±0.05	
MCASU1055CG100DFNA01	UMK105 CG100DVHF	50	GG	COG	10 p	±0.5pF	600	200		0.5±0.05	
MCASU1055CG120JFNA01	UMK105 CG120JVHF	50	GG	COG	12 p	±5%	640	200		0.5±0.05	
MCASU1055CG150JFNA01	UMK105 CG150JVHF	50	GG	COG	15 p	±5%	700	200		0.5±0.05	
MCASU1055CG180JFNA01	UMK105 CG180JVHF	50	GG	COG	18 p	±5%	760	200		0.5±0.05	
MCASU1055CG220JFNA01	UMK105 CG220JVHF	50	GG	COG	22 p	±5%	840	200		0.5±0.05	
MCASU1055CG270JFNA01	UMK105 CG270JVHF	50	GG	COG	27 p	±5%	940	200		0.5±0.05	
MCASU1055CG330JFNA01	UMK105 CG330JVHF	50	GG	COG	33 p	±5%	1000	200		0.5±0.05	
MCASU1055CG390JFNA01	UMK105 CG390JVHF	50	GG	COG	39 p	±5%	1000	200		0.5±0.05	
MCASU1055CG470JFNA01	UMK105 CG470JVHF	50	GG	COG	47 p	±5%	1000	200		0.5±0.05	
MCASU1055CG560JFNA01	UMK105 CG560JVHF	50	GG	COG	56 p	±5%	1000	200		0.5±0.05	
MCASU1055CG680JFNA01	UMK105 CG680JVHF	50	GG	COG	68 p	±5%	1000	200		0.5±0.05	
MCASU1055CG820JFNA01	UMK105 CG820JVHF	50	GG	COG	82 p	±5%	1000	200		0.5±0.05	
MCASU1055CG101JFNA01	UMK105 CG101JVHF	50	GG	COG	100 p	±5%	1000	200		0.5±0.05	
MCASU1055CG121JFNA01	UMK105 CG121JVHF	50	GG	COG	120 p	±5%	1000	200		0.5±0.05	
MCASU1055CG151JFNA01	UMK105 CG151JVHF	50	GG	COG	150 p	±5%	1000	200		0.5±0.05	
MCASU1055CG181JFNA01	UMK105 CG181JVHF	50	GG	COG	180 p	±5%	1000	200		0.5±0.05	
MCASU1055CG221JFNA01	UMK105 CG221JVHF	50	GG	COG	220 p	±5%	1000	200		0.5±0.05	
MCASU1055CG271JFNA01	UMK105 CG271JVHF	50	GG	COG	270 p	±5%	1000	200		0.5±0.05	
MCASU1055CG331JFNA01	UMK105 CG331JVHF	50	GG	COG	330 p	±5%	1000	200		0.5±0.05	
MCASU1055CG391JFNA01	UMK105 CG391JVHF	50	GG	COG	390 p	±5%	1000	200		0.5±0.05	
MCASU1055CG471JFNA01	UMK105 CG471JVHF	50	GG	COG	470 p	±5%	1000	200		0.5±0.05	
MCASU1055CG561JFNA01	UMK105 CG561JVHF	50	GG	COG	560 p	±5%	1000	200		0.5±0.05	
MCASU1055CG681JFNA01	UMK105 CG681JVHF	50	GG	COG	680 p	±5%	1000	200		0.5±0.05	
MCASU1055CG821JFNA01	UMK105 CG821JVHF	50	GG	COG	820 p	±5%	1000	200		0.5±0.05	
MCASU1055CG102JFNA01	UMK105 CG102JVHF	50	GG	COG	1000 p	±5%	1000	200		0.5±0.05	

车载用(车体系·信息系)
多层陶瓷电容器

▶ 由于篇幅有限, 本产品目录中只记载了有代表性的产品规格, 若考虑使用敝公司产品时, 请确认交货规格说明书中的详细规格。
另外, 有关各产品的详细信息(特性图、可靠性信息、使用时的注意事项等), 请参阅敝公司网站(<http://www.ty-top.com/>)。

■型号一览

车载(车身高/情报系)用途 中高耐压多层陶瓷电容器

●1005规格

【温度特性 B7 : X7R (-55~+125°C), C7 : X7S (-55~+125°C)】 0.5mm厚度

新型号	旧型号(参考用)	额定电压 [V]	温度特性	静电容量 [F]	静电容量允许偏差 [%]	tan δ [%]	高温负载		厚度*1 [mm]	注释
							额定电压 x %			
MCASH105SB7221 FCA01	HMK105 B7221 VHFE	100	X7R	220 p	±10, ±20	3.5	200		0.5±0.05	
MCASH105SB7331 FCA01	HMK105 B7331 VHFE	100	X7R	330 p	±10, ±20	3.5	200		0.5±0.05	
MCASH105SB7471 FCA01	HMK105 B7471 VHFE	100	X7R	470 p	±10, ±20	3.5	200		0.5±0.05	
MCASH105SB7681 FCA01	HMK105 B7681 VHFE	100	X7R	680 p	±10, ±20	3.5	200		0.5±0.05	
MCASH105SB7102 FCA01	HMK105 B7102 VHFE	100	X7R	1000 p	±10, ±20	3.5	200		0.5±0.05	
MCASH105SB7152 FCA01	HMK105 B7152 VHFE	100	X7R	1500 p	±10, ±20	3.5	200		0.5±0.05	
MCASH105SB7222 FCA01	HMK105 B7222 VHFE	100	X7R	2200 p	±10, ±20	3.5	200		0.5±0.05	
MCASH105SB7332 FCA01	HMK105 B7332 VHFE	100	X7R	3300 p	±10, ±20	3.5	200		0.5±0.05	
MCASH105SB7472 FCA01	HMK105 B7472 VHFE	100	X7R	4700 p	±10, ±20	3.5	200		0.5±0.05	
MCASH105SB7682 FCA01	HMK105 B7682 VHFE	100	X7R	6800 p	±10, ±20	3.5	200		0.5±0.05	
MCASH105SB7103 FCA01	HMK105 B7103 VHFE	100	X7R	0.01 μ	±10, ±20	3.5	200		0.5±0.05	

●1608规格

【温度特性 B7 : X7R (-55~+125°C), C7 : X7S (-55~+125°C)】 0.8mm厚度

新型号	旧型号(参考用)	额定电压 [V]	温度特性	静电容量 [F]	静电容量允许偏差 [%]	tan δ [%]	高温负载		厚度*1 [mm]	注释
							额定电压 x %			
MCASH168SB7102 TNA01	HMK107 B7102 AHT	100	X7R	1000 p	±10, ±20	3.5	200		0.8±0.10	
MCASH168SB7152 TNA01	HMK107 B7152 AHT	100	X7R	1500 p	±10, ±20	3.5	200		0.8±0.10	
MCASH168SB7222 TNA01	HMK107 B7222 AHT	100	X7R	2200 p	±10, ±20	3.5	200		0.8±0.10	
MCASH168SB7332 TNA01	HMK107 B7332 AHT	100	X7R	3300 p	±10, ±20	3.5	200		0.8±0.10	
MCASH168SB7472 TNA01	HMK107 B7472 AHT	100	X7R	4700 p	±10, ±20	3.5	200		0.8±0.10	
MCASH168SB7682 TNA01	HMK107 B7682 AHT	100	X7R	6800 p	±10, ±20	3.5	200		0.8±0.10	
MCASH168SB7103 TNA01	HMK107 B7103 AHT	100	X7R	0.01 μ	±10, ±20	3.5	200		0.8±0.10	
MCASH168SB7153 TNA01	HMK107 B7153 AHT	100	X7R	0.015 μ	±10, ±20	3.5	200		0.8±0.10	
MCASH168SB7223 TNA01	HMK107 B7223 AHT	100	X7R	0.022 μ	±10, ±20	3.5	200		0.8±0.10	
MCASH168SB7333 TNA01	HMK107 B7333 AHT	100	X7R	0.033 μ	±10, ±20	3.5	200		0.8±0.10	
MCASH168SB7473 TNA01	HMK107 B7473 AHT	100	X7R	0.047 μ	±10, ±20	3.5	200		0.8±0.10	
MCASH168AB7683 TCA01	HMK107AB7683 AHTE	100	X7R	0.068 μ	±10, ±20	3.5	200		0.8±0.15/-0.05	
MCASH168SB7104 TNA01	HMK107 B7104 AHT	100	X7R	0.1 μ	±10, ±20	3.5	200		0.8±0.10	
MCASH168AC7154 TCA01	HMK107AC7154 AHTE	100	X7S	0.15 μ	±10, ±20	3.5	150		0.8±0.15/-0.05	
MCASH168SC7224 TCA01	HMK107 C7224 AHTE	100	X7S	0.22 μ	±10, ±20	3.5	150		0.8±0.10	

●2012规格

【温度特性 B7 : X7R (-55~+125°C), C7 : X7S (-55~+125°C)】 1.25mm厚度

新型号	旧型号(参考用)	额定电压 [V]	温度特性	静电容量 [F]	静电容量允许偏差 [%]	tan δ [%]	高温负载		厚度*1 [mm]	注释
							额定电压 x %			
MCASH21GSB7472 TNA01	HMK212 B7472 GHT	100	X7R	4700 p	±10, ±20	2.5	200		1.25±0.10	
MCASH21GSB7682 TNA01	HMK212 B7682 GHT	100	X7R	6800 p	±10, ±20	2.5	200		1.25±0.10	
MCASH21GSB7103 TNA01	HMK212 B7103 GHT	100	X7R	0.01 μ	±10, ±20	3.5	200		1.25±0.10	
MCASH21GSB7153 TNA01	HMK212 B7153 GHT	100	X7R	0.015 μ	±10, ±20	3.5	200		1.25±0.10	
MCASH21GSB7223 TNA01	HMK212 B7223 GHT	100	X7R	0.022 μ	±10, ±20	3.5	200		1.25±0.10	
MCASH21GSB7333 TNA01	HMK212 B7333 GHT	100	X7R	0.033 μ	±10, ±20	3.5	200		1.25±0.10	
MCASH21GSB7473 TNA01	HMK212 B7473 GHT	100	X7R	0.047 μ	±10, ±20	3.5	200		1.25±0.10	
MCASH21GSB7683 TNA01	HMK212 B7683 GHT	100	X7R	0.068 μ	±10, ±20	3.5	200		1.25±0.10	
MCASH21GSB7104 TNA01	HMK212 B7104 GHT	100	X7R	0.1 μ	±10, ±20	3.5	200		1.25±0.10	
MCASH21GSB7154 TCA01	HMK212BB7154 GHTE	100	X7R	0.15 μ	±10, ±20	3.5	200		1.25±0.20/-0	
MCASH21GSB7224 TNA01	HMK212 B7224 GHT	100	X7R	0.22 μ	±10, ±20	3.5	200		1.25±0.10	
MCASH21GBC7334 TCA01	HMK212BC7334 GHTE	100	X7S	0.33 μ	±10, ±20	3.5	150		1.25±0.20/-0	
MCASH21GSC7474 TCA01	HMK212 C7474 GHTE	100	X7S	0.47 μ	±10, ±20	3.5	150		1.25±0.10	
MCASH21GCC7684 TCA01	HMK212CC7684 GHTE	100	X7S	0.68 μ	±10, ±20	3.5	150		1.25±0.25/-0	
MCASH21GBC7105 TCA01	HMK212BC7105 GHTE	100	X7S	1 μ	±10, ±20	3.5	150		1.25±0.20/-0	
MCASQ21GSB7472 TNA01	QMK212 B7472 GHT	250	X7R	4700 p	±10, ±20	2.5	150		1.25±0.10	
MCASQ21GSB7682 TNA01	QMK212 B7682 GHT	250	X7R	6800 p	±10, ±20	2.5	150		1.25±0.10	
MCASQ21GSB7103 TNA01	QMK212 B7103 GHT	250	X7R	0.01 μ	±10, ±20	2.5	150		1.25±0.10	
MCASQ21GSB7153 TNA01	QMK212 B7153 GHT	250	X7R	0.015 μ	±10, ±20	2.5	150		1.25±0.10	
MCASQ21GSB7223 TNA01	QMK212 B7223 GHT	250	X7R	0.022 μ	±10, ±20	2.5	150		1.25±0.10	

【温度特性 B7 : X7R (-55~+125°C)】 0.85mm厚度

新型号	旧型号(参考用)	额定电压 [V]	温度特性	静电容量 [F]	静电容量允许偏差 [%]	tan δ [%]	高温负载		厚度*1 [mm]	注释
							额定电压 x %			
MCASH219SB7102 TNA01	HMK212 B7102 DHT	100	X7R	1000 p	±10, ±20	2.5	200		0.85±0.10	
MCASH219SB7152 TNA01	HMK212 B7152 DHT	100	X7R	1500 p	±10, ±20	2.5	200		0.85±0.10	
MCASH219SB7222 TNA01	HMK212 B7222 DHT	100	X7R	2200 p	±10, ±20	2.5	200		0.85±0.10	
MCASH219SB7332 TNA01	HMK212 B7332 DHT	100	X7R	3300 p	±10, ±20	2.5	200		0.85±0.10	
MCASQ219SB7102 TNA01	QMK212 B7102 DHT	250	X7R	1000 p	±10, ±20	2.5	150		0.85±0.10	
MCASQ219SB7152 TNA01	QMK212 B7152 DHT	250	X7R	1500 p	±10, ±20	2.5	150		0.85±0.10	
MCASQ219SB7222 TNA01	QMK212 B7222 DHT	250	X7R	2200 p	±10, ±20	2.5	150		0.85±0.10	
MCASQ219SB7332 TNA01	QMK212 B7332 DHT	250	X7R	3300 p	±10, ±20	2.5	150		0.85±0.10	

▶ 由于篇幅有限, 本产品目录中只记载了有代表性的产品规格, 若考虑使用敝公司产品时, 请确认交货规格说明书中的详细规格。另外, 有关各产品的详细信息(特性图、可靠性信息、使用时的注意事项等), 请参阅敝公司网站(<http://www.ty-top.com/>)。

■型号一览

●3216规格

【温度特性 B7 : X7R (-55~+125℃), C7 : X7S (-55~+125℃)】 1.6mm厚度

新型号	旧型号(参考用)	额定电压 [V]	温度特性		静电容量 [F]	静电容量允许偏差 [%]	tan δ [%]	高温负载		厚度*1 [mm]	注释
								额定电压 x %			
MCASH31LSB7473 □ TNA01	HMK316 B7473 □ LHT	100		X7R	0.047 μ	±10, ±20	3.5	200		1.6±0.20	
MCASH31LSB7683 □ TNA01	HMK316 B7683 □ LHT	100		X7R	0.068 μ	±10, ±20	3.5	200		1.6±0.20	
MCASH31LSB7104 □ TNA01	HMK316 B7104 □ LHT	100		X7R	0.1 μ	±10, ±20	3.5	200		1.6±0.20	
MCASH31LSB7154 □ TNA01	HMK316 B7154 □ LHT	100		X7R	0.15 μ	±10, ±20	3.5	200		1.6±0.20	
MCASH31LSB7224 □ TNA01	HMK316 B7224 □ LHT	100		X7R	0.22 μ	±10, ±20	3.5	200		1.6±0.20	
MCASH31LSB7334 □ TNA01	HMK316 B7334 □ LHT	100		X7R	0.33 μ	±10, ±20	3.5	200		1.6±0.20	
MCASH31LSB7474 □ TNA01	HMK316 B7474 □ LHT	100		X7R	0.47 μ	±10, ±20	3.5	200		1.6±0.20	
MCASH31LSB7105 □ TNA01	HMK316 B7105 □ LHT	100		X7R	1 μ	±10, ±20	3.5	200		1.6±0.20	
MCASH31LBC7155 □ TCA01	HMK316BC7155 □ LHTE	100		X7S	1.5 μ	±10, ±20	3.5	150		1.6±0.30	
MCASH31LAC7225 □ TGA01	HMK316AC7225 □ LHTE	100		X7S	2.2 μ	±10, ±20	3.5	150		1.6±0.20	
MCASQ31LSB7223 □ TNA01	QMK316 B7223 □ LHT	250		X7R	0.022 μ	±10, ±20	2.5	150		1.6±0.20	
MCASQ31LSB7333 □ TNA01	QMK316 B7333 □ LHT	250		X7R	0.033 μ	±10, ±20	2.5	150		1.6±0.20	
MCASQ31LSB7473 □ TNA01	QMK316 B7473 □ LHT	250		X7R	0.047 μ	±10, ±20	2.5	150		1.6±0.20	
MCASQ31LSB7683 □ TNA01	QMK316 B7683 □ LHT	250		X7R	0.068 μ	±10, ±20	2.5	150		1.6±0.20	
MCASQ31LSB7104 □ TNA01	QMK316 B7104 □ LHT	250		X7R	0.1 μ	±10, ±20	2.5	150		1.6±0.20	
MCASS31LSB7153 □ TNA01	SMK316 B7153 □ LHT	630		X7R	0.015 μ	±10, ±20	2.5	120		1.6±0.20	
MCASS31LSB7223 □ TNA01	SMK316 B7223 □ LHT	630		X7R	0.022 μ	±10, ±20	2.5	120		1.6±0.20	
MCASS31LAB7333 □ TNA01	SMK316AB7333 □ LHT	630		X7R	0.033 μ	±10, ±20	2.5	120		1.6±0.20	
MCASS31LAB7473 □ TNA01	SMK316AB7473 □ LHT	630		X7R	0.047 μ	±10, ±20	2.5	120		1.6±0.20	

【温度特性 B7 : X7R (-55~+125℃)】 1.15mm厚度

新型号	旧型号(参考用)	额定电压 [V]	温度特性		静电容量 [F]	静电容量允许偏差 [%]	tan δ [%]	高温负载		厚度*1 [mm]	注释
								额定电压 x %			
MCASS31QHB7102 □ TNA01	SMK316 B7102 □ FHT	630		X7R	1000 p	±10, ±20	2.5	120		1.15±0.10	
MCASS31QHB7152 □ TNA01	SMK316 B7152 □ FHT	630		X7R	1500 p	±10, ±20	2.5	120		1.15±0.10	
MCASS31QHB7222 □ TNA01	SMK316 B7222 □ FHT	630		X7R	2200 p	±10, ±20	2.5	120		1.15±0.10	
MCASS31QHB7332 □ TNA01	SMK316 B7332 □ FHT	630		X7R	3300 p	±10, ±20	2.5	120		1.15±0.10	
MCASS31QHB7472 □ TNA01	SMK316 B7472 □ FHT	630		X7R	4700 p	±10, ±20	2.5	120		1.15±0.10	
MCASS31QHB7682 □ TNA01	SMK316 B7682 □ FHT	630		X7R	6800 p	±10, ±20	2.5	120		1.15±0.10	
MCASS31QHB7103 □ TNA01	SMK316 B7103 □ FHT	630		X7R	0.01 μ	±10, ±20	2.5	120		1.15±0.10	

●3225规格

【温度特性 B7 : X7R (-55~+125℃), C7 : X7S (-55~+125℃)】 2.5mm厚度

新型号	旧型号(参考用)	额定电压 [V]	温度特性		静电容量 [F]	静电容量允许偏差 [%]	tan δ [%]	高温负载		厚度*1 [mm]	注释
								额定电压 x %			
MCASH32MSB7225 □ PNA01	HMK325 B7225 □ MHP	100		X7R	2.2 μ	±10, ±20	3.5	200		2.5±0.20	
MCASH32MSC7475 □ PGA01	HMK325 C7475 □ MHPPE	100		X7S	4.7 μ	±10, ±20	3.5	150		2.5±0.20	

【温度特性 B7 : X7R (-55~+125℃)】 1.9mm厚度

新型号	旧型号(参考用)	额定电压 [V]	温度特性		静电容量 [F]	静电容量允许偏差 [%]	tan δ [%]	高温负载		厚度*1 [mm]	注释
								额定电压 x %			
MCASH32NSB7224 □ TNA01	HMK325 B7224 □ NHT	100		X7R	0.22 μ	±10, ±20	3.5	200		1.9±0.20	
MCASH32NSB7474 □ TNA01	HMK325 B7474 □ NHT	100		X7R	0.47 μ	±10, ±20	3.5	200		1.9±0.20	
MCASH32NSB7684 □ TNA01	HMK325 B7684 □ NHT	100		X7R	0.68 μ	±10, ±20	3.5	200		1.9±0.20	
MCASH32NSB7105 □ TNA01	HMK325 B7105 □ NHT	100		X7R	1 μ	±10, ±20	3.5	200		1.9±0.20	
MCASQ32NSB7473 □ TNA01	QMK325 B7473 □ NHT	250		X7R	0.047 μ	±10, ±20	2.5	150		1.9±0.20	
MCASQ32NSB7104 □ TNA01	QMK325 B7104 □ NHT	250		X7R	0.1 μ	±10, ±20	2.5	150		1.9±0.20	
MCASQ32NSB7154 □ TNA01	QMK325 B7154 □ NHT	250		X7R	0.15 μ	±10, ±20	2.5	150		1.9±0.20	
MCASQ32NSB7224 □ TNA01	QMK325 B7224 □ NHT	250		X7R	0.22 μ	±10, ±20	2.5	150		1.9±0.20	
MCASS32NSB7223 □ TNA01	SMK325 B7223 □ NHT	630		X7R	0.022 μ	±10, ±20	2.5	120		1.9±0.20	
MCASS32NSB7333 □ TNA01	SMK325 B7333 □ NHT	630		X7R	0.033 μ	±10, ±20	2.5	120		1.9±0.20	
MCASS32NSB7473 □ TNA01	SMK325 B7473 □ NHT	630		X7R	0.047 μ	±10, ±20	2.5	120		1.9±0.20	

●4532规格

【温度特性 B7 : X7R (-55~+125℃)】 2.5mm厚度

新型号	旧型号(参考用)	额定电压 [V]	温度特性		静电容量 [F]	静电容量允许偏差 [%]	tan δ [%]	高温负载		厚度*1 [mm]	注释
								额定电压 x %			
MCASH45MSB7474 □ TNA01	HMK432 B7474 □ MHT	100		X7R	0.47 μ	±10, ±20	3.5	200		2.5±0.20	
MCASH45MSB7105 □ TNA01	HMK432 B7105 □ MHT	100		X7R	1 μ	±10, ±20	3.5	200		2.5±0.20	
MCASH45MSB7155 □ TNA01	HMK432 B7155 □ MHT	100		X7R	1.5 μ	±10, ±20	3.5	200		2.5±0.20	
MCASH45MSB7225 □ TNA01	HMK432 B7225 □ MHT	100		X7R	2.2 μ	±10, ±20	3.5	200		2.5±0.20	
MCASQ45MSB7104 □ TNA01	QMK432 B7104 □ MHT	250		X7R	0.1 μ	±10, ±20	2.5	150		2.5±0.20	
MCASQ45MSB7224 □ TNA01	QMK432 B7224 □ MHT	250		X7R	0.22 μ	±10, ±20	2.5	150		2.5±0.20	
MCASQ45MSB7334 □ TNA01	QMK432 B7334 □ MHT	250		X7R	0.33 μ	±10, ±20	2.5	150		2.5±0.20	
MCASQ45MSB7474 □ TNA01	QMK432 B7474 □ MHT	250		X7R	0.47 μ	±10, ±20	2.5	150		2.5±0.20	
MCASS45MSB7473 □ TNA01	SMK432 B7473 □ MHT	630		X7R	0.047 μ	±10, ±20	2.5	120		2.5±0.20	
MCASS45MSB7683 □ TNA01	SMK432 B7683 □ MHT	630		X7R	0.068 μ	±10, ±20	2.5	120		2.5±0.20	
MCASS45MSB7104 □ TNA01	SMK432 B7104 □ MHT	630		X7R	0.1 μ	±10, ±20	2.5	120		2.5±0.20	

▶ 由于篇幅有限, 本产品目录中只记载了有代表性的产品规格, 若考虑使用敝公司产品时, 请确认交货规格说明书中的详细规格。
另外, 有关各产品的详细信息(特性图、可靠性信息、使用时的注意事项等), 请参阅敝公司网站(<http://www.ty-top.com/>)。

车载(车身分/情报系)用途 高频/低损耗中高耐压多层陶瓷电容器

●1005规格

【温度特性 CG : CG/CGG (-55~+125°C)】 0.5mm厚度

新型号	旧型号(参考用)	额定电压 [V]	温度特性		静电容量 [F]	静电容量允许偏差	Q值 [at 1MHz] (Min)	高温负载	厚度*1 [mm]	注释
								额定电压 x %		
MCARQ105SCG0R5 []FRA01	QVS105 CG0R5 []VHF	250	CG	CGG	0.5 p	±0.1pF, ±0.25pF	810	200	0.5±0.05	
MCARQ105SCG0R6 []FRA01	QVS105 CG0R6 []VHF	250	CG	CGG	0.6 p	±0.1pF, ±0.25pF	812	200	0.5±0.05	
MCARQ105SCG0R7 []FRA01	QVS105 CG0R7 []VHF	250	CG	CGG	0.7 p	±0.1pF, ±0.25pF	814	200	0.5±0.05	
MCARQ105SCG0R75 []FRA01	QVS105 CG0R75 []VHF	250	CG	CGG	0.75 p	±0.1pF, ±0.25pF	815	200	0.5±0.05	
MCARQ105SCG0R8 []FRA01	QVS105 CG0R8 []VHF	250	CG	CGG	0.8 p	±0.1pF, ±0.25pF	816	200	0.5±0.05	
MCARQ105SCG0R9 []FRA01	QVS105 CG0R9 []VHF	250	CG	CGG	0.9 p	±0.1pF, ±0.25pF	818	200	0.5±0.05	
MCARQ105SCG010 []FRA01	QVS105 CG010 []VHF	250	CG	CGG	1 p	±0.1pF, ±0.25pF	820	200	0.5±0.05	
MCARQ105SCG1R1 []FRA01	QVS105 CG1R1 []VHF	250	CG	CGG	1.1 p	±0.1pF, ±0.25pF	822	200	0.5±0.05	
MCARQ105SCG1R2 []FRA01	QVS105 CG1R2 []VHF	250	CG	CGG	1.2 p	±0.1pF, ±0.25pF	824	200	0.5±0.05	
MCARQ105SCG1R3 []FRA01	QVS105 CG1R3 []VHF	250	CG	CGG	1.3 p	±0.1pF, ±0.25pF	826	200	0.5±0.05	
MCARQ105SCG1R5 []FRA01	QVS105 CG1R5 []VHF	250	CG	CGG	1.5 p	±0.1pF, ±0.25pF	830	200	0.5±0.05	
MCARQ105SCG1R6 []FRA01	QVS105 CG1R6 []VHF	250	CG	CGG	1.6 p	±0.1pF, ±0.25pF	832	200	0.5±0.05	
MCARQ105SCG1R8 []FRA01	QVS105 CG1R8 []VHF	250	CG	CGG	1.8 p	±0.1pF, ±0.25pF	836	200	0.5±0.05	
MCARQ105SCG020 []FRA01	QVS105 CG020 []VHF	250	CG	CGG	2 p	±0.1pF, ±0.25pF	840	200	0.5±0.05	
MCARQ105SCG2R2 []FRA01	QVS105 CG2R2 []VHF	250	CG	CGG	2.2 p	±0.1pF, ±0.25pF	844	200	0.5±0.05	
MCARQ105SCG2R4 []FRA01	QVS105 CG2R4 []VHF	250	CG	CGG	2.4 p	±0.1pF, ±0.25pF	848	200	0.5±0.05	
MCARQ105SCG2R7 []FRA01	QVS105 CG2R7 []VHF	250	CG	CGG	2.7 p	±0.1pF, ±0.25pF	854	200	0.5±0.05	
MCARQ105SCG030 []FRA01	QVS105 CG030 []VHF	250	CG	CGG	3 p	±0.1pF, ±0.25pF	860	200	0.5±0.05	
MCARQ105SCG3R3 []FRA01	QVS105 CG3R3 []VHF	250	CG	CGG	3.3 p	±0.1pF, ±0.25pF	866	200	0.5±0.05	
MCARQ105SCG3R6 []FRA01	QVS105 CG3R6 []VHF	250	CG	CGG	3.6 p	±0.1pF, ±0.25pF	872	200	0.5±0.05	
MCARQ105SCG3R9 []FRA01	QVS105 CG3R9 []VHF	250	CG	CGG	3.9 p	±0.1pF, ±0.25pF	878	200	0.5±0.05	
MCARQ105SCG4R3 []FRA01	QVS105 CG4R3 []VHF	250	CG	CGG	4.3 p	±0.1pF, ±0.25pF	886	200	0.5±0.05	
MCARQ105SCG4R7 []FRA01	QVS105 CG4R7 []VHF	250	CG	CGG	4.7 p	±0.1pF, ±0.25pF	894	200	0.5±0.05	
MCARQ105SCG5R1 []FRA01	QVS105 CG5R1 []VHF	250	CG	CGG	5.1 p	±0.25pF, ±0.5pF	902	200	0.5±0.05	
MCARQ105SCG5R6 []FRA01	QVS105 CG5R6 []VHF	250	CG	CGG	5.6 p	±0.25pF, ±0.5pF	912	200	0.5±0.05	
MCARQ105SCG6R2 []FRA01	QVS105 CG6R2 []VHF	250	CG	CGG	6.2 p	±0.25pF, ±0.5pF	924	200	0.5±0.05	
MCARQ105SCG6R8 []FRA01	QVS105 CG6R8 []VHF	250	CG	CGG	6.8 p	±0.25pF, ±0.5pF	936	200	0.5±0.05	
MCARQ105SCG7R5 []FRA01	QVS105 CG7R5 []VHF	250	CG	CGG	7.5 p	±0.25pF, ±0.5pF	950	200	0.5±0.05	
MCARQ105SCG8R2 []FRA01	QVS105 CG8R2 []VHF	250	CG	CGG	8.2 p	±0.25pF, ±0.5pF	964	200	0.5±0.05	
MCARQ105SCG9R1 []FRA01	QVS105 CG9R1 []VHF	250	CG	CGG	9.1 p	±0.25pF, ±0.5pF	982	200	0.5±0.05	
MCARQ105SCG100JFRA01	QVS105 CG100JVHF	250	CG	CGG	10 p	±5%	1000	200	0.5±0.05	
MCARQ105SCG110JFRA01	QVS105 CG110JVHF	250	CG	CGG	11 p	±5%	1020	200	0.5±0.05	
MCARQ105SCG120JFRA01	QVS105 CG120JVHF	250	CG	CGG	12 p	±5%	1040	200	0.5±0.05	
MCARQ105SCG130JFRA01	QVS105 CG130JVHF	250	CG	CGG	13 p	±5%	1060	200	0.5±0.05	
MCARQ105SCG150JFRA01	QVS105 CG150JVHF	250	CG	CGG	15 p	±5%	1100	200	0.5±0.05	
MCARQ105SCG160JFRA01	QVS105 CG160JVHF	250	CG	CGG	16 p	±5%	1120	200	0.5±0.05	
MCARQ105SCG180JFRA01	QVS105 CG180JVHF	250	CG	CGG	18 p	±5%	1160	200	0.5±0.05	
MCARQ105SCG200JFRA01	QVS105 CG200JVHF	250	CG	CGG	20 p	±5%	1200	200	0.5±0.05	
MCARQ105SCG220JFRA01	QVS105 CG220JVHF	250	CG	CGG	22 p	±5%	1240	200	0.5±0.05	
MCARQ105SCG240JFRA01	QVS105 CG240JVHF	250	CG	CGG	24 p	±5%	1280	200	0.5±0.05	
MCARQ105SCG270JFRA01	QVS105 CG270JVHF	250	CG	CGG	27 p	±5%	1340	200	0.5±0.05	
MCARQ105SCG300JFRA01	QVS105 CG300JVHF	250	CG	CGG	30 p	±5%	1400	200	0.5±0.05	
MCARQ105SCG330JFRA01	QVS105 CG330JVHF	250	CG	CGG	33 p	±5%	1400	200	0.5±0.05	

▶由于篇幅有限,本产品目录中只记载了有代表性的产品规格,若考虑使用敝公司产品时,请确认交货规格说明书中的详细规格。另外,有关各产品的详细信息(特性图、可靠性信息、使用时的注意事项等),请参阅敝公司网站(<http://www.ty-top.com/>)。

■型号一览

●1608规格

【温度特性 CG : CG/COG (-55~+125°C)】 0.7mm厚度

新型号	旧型号(参考用)	额定电压 [V]	温度特性		静电容量 [F]	静电容量允许偏差	Q值 [at 1MHz] (Min)	高温负载		厚度*1 [mm]	注释
								额定电压 x %			
MCARQ167SCG0R2 [] TRA01	QVS107 CG0R2 [] CHT	250	CG	CG	0.2 p	±0.05pF, ±0.1pF	804	200		0.7±0.10	
MCARQ167SCG0R3 [] TRA01	QVS107 CG0R3 [] CHT	250	CG	CG	0.3 p	±0.05pF, ±0.1pF	806	200		0.7±0.10	
MCARQ167SCG0R4 [] TRA01	QVS107 CG0R4 [] CHT	250	CG	CG	0.4 p	±0.05pF, ±0.1pF	808	200		0.7±0.10	
MCARQ167SCG0R5 [] TRA01	QVS107 CG0R5 [] CHT	250	CG	CG	0.5 p	±0.1pF, ±0.25pF	810	200		0.7±0.10	
MCARQ167SCG0R6 [] TRA01	QVS107 CG0R6 [] CHT	250	CG	CG	0.6 p	±0.1pF, ±0.25pF	812	200		0.7±0.10	
MCARQ167SCG0R7 [] TRA01	QVS107 CG0R7 [] CHT	250	CG	CG	0.7 p	±0.1pF, ±0.25pF	814	200		0.7±0.10	
MCARQ167SCG0R75 [] TRA01	QVS107 CGR75 [] CHT	250	CG	CG	0.75 p	±0.1pF, ±0.25pF	815	200		0.7±0.10	
MCARQ167SCG0R8 [] TRA01	QVS107 CG0R8 [] CHT	250	CG	CG	0.8 p	±0.1pF, ±0.25pF	816	200		0.7±0.10	
MCARQ167SCG0R9 [] TRA01	QVS107 CG0R9 [] CHT	250	CG	CG	0.9 p	±0.1pF, ±0.25pF	818	200		0.7±0.10	
MCARQ167SCG010 [] TRA01	QVS107 CG010 [] CHT	250	CG	CG	1 p	±0.1pF, ±0.25pF	820	200		0.7±0.10	
MCARQ167SCG01R1 [] TRA01	QVS107 CG1R1 [] CHT	250	CG	CG	1.1 p	±0.1pF, ±0.25pF	822	200		0.7±0.10	
MCARQ167SCG01R2 [] TRA01	QVS107 CG1R2 [] CHT	250	CG	CG	1.2 p	±0.1pF, ±0.25pF	824	200		0.7±0.10	
MCARQ167SCG01R3 [] TRA01	QVS107 CG1R3 [] CHT	250	CG	CG	1.3 p	±0.1pF, ±0.25pF	826	200		0.7±0.10	
MCARQ167SCG01R5 [] TRA01	QVS107 CG1R5 [] CHT	250	CG	CG	1.5 p	±0.1pF, ±0.25pF	830	200		0.7±0.10	
MCARQ167SCG01R6 [] TRA01	QVS107 CG1R6 [] CHT	250	CG	CG	1.6 p	±0.1pF, ±0.25pF	832	200		0.7±0.10	
MCARQ167SCG01R8 [] TRA01	QVS107 CG1R8 [] CHT	250	CG	CG	1.8 p	±0.1pF, ±0.25pF	836	200		0.7±0.10	
MCARQ167SCG020 [] TRA01	QVS107 CG020 [] CHT	250	CG	CG	2 p	±0.1pF, ±0.25pF	840	200		0.7±0.10	
MCARQ167SCG2R2 [] TRA01	QVS107 CG2R2 [] CHT	250	CG	CG	2.2 p	±0.1pF, ±0.25pF	844	200		0.7±0.10	
MCARQ167SCG2R4 [] TRA01	QVS107 CG2R4 [] CHT	250	CG	CG	2.4 p	±0.1pF, ±0.25pF	848	200		0.7±0.10	
MCARQ167SCG2R7 [] TRA01	QVS107 CG2R7 [] CHT	250	CG	CG	2.7 p	±0.1pF, ±0.25pF	854	200		0.7±0.10	
MCARQ167SCG030 [] TRA01	QVS107 CG030 [] CHT	250	CG	CG	3 p	±0.1pF, ±0.25pF	860	200		0.7±0.10	
MCARQ167SCG3R3 [] TRA01	QVS107 CG3R3 [] CHT	250	CG	CG	3.3 p	±0.1pF, ±0.25pF	866	200		0.7±0.10	
MCARQ167SCG3R6 [] TRA01	QVS107 CG3R6 [] CHT	250	CG	CG	3.6 p	±0.1pF, ±0.25pF	872	200		0.7±0.10	
MCARQ167SCG3R9 [] TRA01	QVS107 CG3R9 [] CHT	250	CG	CG	3.9 p	±0.1pF, ±0.25pF	878	200		0.7±0.10	
MCARQ167SCG4R3 [] TRA01	QVS107 CG4R3 [] CHT	250	CG	CG	4.3 p	±0.1pF, ±0.25pF	886	200		0.7±0.10	
MCARQ167SCG4R7 [] TRA01	QVS107 CG4R7 [] CHT	250	CG	CG	4.7 p	±0.1pF, ±0.25pF	894	200		0.7±0.10	
MCARQ167SCG5R1 [] TRA01	QVS107 CG5R1 [] CHT	250	CG	CG	5.1 p	±0.25pF, ±0.5pF	902	200		0.7±0.10	
MCARQ167SCG5R6 [] TRA01	QVS107 CG5R6 [] CHT	250	CG	CG	5.6 p	±0.25pF, ±0.5pF	912	200		0.7±0.10	
MCARQ167SCG6R2 [] TRA01	QVS107 CG6R2 [] CHT	250	CG	CG	6.2 p	±0.25pF, ±0.5pF	924	200		0.7±0.10	
MCARQ167SCG6R8 [] TRA01	QVS107 CG6R8 [] CHT	250	CG	CG	6.8 p	±0.25pF, ±0.5pF	936	200		0.7±0.10	
MCARQ167SCG7R5 [] TRA01	QVS107 CG7R5 [] CHT	250	CG	CG	7.5 p	±0.25pF, ±0.5pF	950	200		0.7±0.10	
MCARQ167SCG8R2 [] TRA01	QVS107 CG8R2 [] CHT	250	CG	CG	8.2 p	±0.25pF, ±0.5pF	964	200		0.7±0.10	
MCARQ167SCG9R1 [] TRA01	QVS107 CG9R1 [] CHT	250	CG	CG	9.1 p	±0.25pF, ±0.5pF	982	200		0.7±0.10	
MCARQ167SCG100 [] TRA01	QVS107 CG100 [] CHT	250	CG	CG	10 p	±2%, ±5%	1000	200		0.7±0.10	
MCARQ167SCG110JTRA01	QVS107 CG110JCHT	250	CG	CG	11 p	±5%	1020	200		0.7±0.10	
MCARQ167SCG120JTRA01	QVS107 CG120JCHT	250	CG	CG	12 p	±5%	1040	200		0.7±0.10	
MCARQ167SCG130JTRA01	QVS107 CG130JCHT	250	CG	CG	13 p	±5%	1060	200		0.7±0.10	
MCARQ167SCG150JTRA01	QVS107 CG150JCHT	250	CG	CG	15 p	±5%	1100	200		0.7±0.10	
MCARQ167SCG160JTRA01	QVS107 CG160JCHT	250	CG	CG	16 p	±5%	1120	200		0.7±0.10	
MCARQ167SCG180JTRA01	QVS107 CG180JCHT	250	CG	CG	18 p	±5%	1160	200		0.7±0.10	
MCARQ167SCG200JTRA01	QVS107 CG200JCHT	250	CG	CG	20 p	±5%	1200	200		0.7±0.10	
MCARQ167SCG220JTRA01	QVS107 CG220JCHT	250	CG	CG	22 p	±5%	1240	200		0.7±0.10	
MCARQ167SCG240JTRA01	QVS107 CG240JCHT	250	CG	CG	24 p	±5%	1280	200		0.7±0.10	
MCARQ167SCG270JTRA01	QVS107 CG270JCHT	250	CG	CG	27 p	±5%	1340	200		0.7±0.10	
MCARQ167SCG300JTRA01	QVS107 CG300JCHT	250	CG	CG	30 p	±5%	1400	200		0.7±0.10	
MCARQ167SCG330JTRA01	QVS107 CG330JCHT	250	CG	CG	33 p	±5%	1400	200		0.7±0.10	
MCARQ167SCG360JTRA01	QVS107 CG360JCHT	250	CG	CG	36 p	±5%	1400	200		0.7±0.10	
MCARQ167SCG390JTRA01	QVS107 CG390JCHT	250	CG	CG	39 p	±5%	1400	200		0.7±0.10	
MCARQ167SCG430JTRA01	QVS107 CG430JCHT	250	CG	CG	43 p	±5%	1400	200		0.7±0.10	
MCARQ167SCG470JTRA01	QVS107 CG470JCHT	250	CG	CG	47 p	±5%	1400	200		0.7±0.10	
MCARQ167SCG510JTRA01	QVS107 CG510JCHT	250	CG	CG	51 p	±5%	1400	200		0.7±0.10	
MCARQ167SCG560JTRA01	QVS107 CG560JCHT	250	CG	CG	56 p	±5%	1400	200		0.7±0.10	
MCARQ167SCG620JTRA01	QVS107 CG620JCHT	250	CG	CG	62 p	±5%	1400	200		0.7±0.10	
MCARQ167SCG680JTRA01	QVS107 CG680JCHT	250	CG	CG	68 p	±5%	1400	200		0.7±0.10	
MCARQ167SCG750JTRA01	QVS107 CG750JCHT	250	CG	CG	75 p	±5%	1400	200		0.7±0.10	
MCARQ167SCG820JTRA01	QVS107 CG820JCHT	250	CG	CG	82 p	±5%	1400	200		0.7±0.10	
MCARQ167SCG910JTRA01	QVS107 CG910JCHT	250	CG	CG	91 p	±5%	1400	200		0.7±0.10	
MCARQ167SCG101JTRA01	QVS107 CG101JCHT	250	CG	CG	100 p	±5%	1400	200		0.7±0.10	

车载用(车身系·信息系)

多层陶瓷电容器

▶ 由于篇幅有限, 本产品目录中只记载了有代表性的产品规格, 若考虑使用敝公司产品时, 请确认交货规格说明书中的详细规格。
另外, 有关各产品的详细信息(特性图、可靠性信息、使用时的注意事项等), 请参阅敝公司网站(<http://www.ty-top.com/>)。

■型号一览

●2012规格

【温度特性 CG : CG/COG (-55~+125°C)】 0.85mm厚度

新型号	旧型号(参考用)	额定电压 [V]	温度特性		静电容量 [F]	静电容量允许偏差	Q值 [at 1MHz] (Min)	高温负载	厚度*1 [mm]	注释
								额定电压 x %		
MCARQ219SCG0R3 [] TRA01	QVS212 CG0R3 [] DHT	250	CG	COG	0.3 p	±0.05pF, ±0.1pF, ±0.25p	806	200	0.85±0.10	
MCARQ219SCG0R4 [] TRA01	QVS212 CG0R4 [] DHT	250	CG	COG	0.4 p	±0.05pF, ±0.1pF, ±0.25p	808	200	0.85±0.10	
MCARQ219SCG0R5 [] TRA01	QVS212 CG0R5 [] DHT	250	CG	COG	0.5 p	±0.1pF, ±0.25pF	810	200	0.85±0.10	
MCARQ219SCG0R6 [] TRA01	QVS212 CG0R6 [] DHT	250	CG	COG	0.6 p	±0.1pF, ±0.25pF	812	200	0.85±0.10	
MCARQ219SCG0R7 [] TRA01	QVS212 CG0R7 [] DHT	250	CG	COG	0.7 p	±0.1pF, ±0.25pF	814	200	0.85±0.10	
MCARQ219SCG0R75 [] TRA01	QVS212 CGR75 [] DHT	250	CG	COG	0.75 p	±0.1pF, ±0.25pF	815	200	0.85±0.10	
MCARQ219SCG0R8 [] TRA01	QVS212 CG0R8 [] DHT	250	CG	COG	0.8 p	±0.1pF, ±0.25pF	816	200	0.85±0.10	
MCARQ219SCG0R9 [] TRA01	QVS212 CG0R9 [] DHT	250	CG	COG	0.9 p	±0.1pF, ±0.25pF	818	200	0.85±0.10	
MCARQ219SCG010 [] TRA01	QVS212 CG010 [] DHT	250	CG	COG	1 p	±0.1pF, ±0.25pF	820	200	0.85±0.10	
MCARQ219SCG1R1 [] TRA01	QVS212 CG1R1 [] DHT	250	CG	COG	1.1 p	±0.1pF, ±0.25pF	822	200	0.85±0.10	
MCARQ219SCG1R2 [] TRA01	QVS212 CG1R2 [] DHT	250	CG	COG	1.2 p	±0.1pF, ±0.25pF	824	200	0.85±0.10	
MCARQ219SCG1R3 [] TRA01	QVS212 CG1R3 [] DHT	250	CG	COG	1.3 p	±0.1pF, ±0.25pF	826	200	0.85±0.10	
MCARQ219SCG1R5 [] TRA01	QVS212 CG1R5 [] DHT	250	CG	COG	1.5 p	±0.1pF, ±0.25pF	830	200	0.85±0.10	
MCARQ219SCG1R6 [] TRA01	QVS212 CG1R6 [] DHT	250	CG	COG	1.6 p	±0.1pF, ±0.25pF	832	200	0.85±0.10	
MCARQ219SCG1R8 [] TRA01	QVS212 CG1R8 [] DHT	250	CG	COG	1.8 p	±0.1pF, ±0.25pF	836	200	0.85±0.10	
MCARQ219SCG020 [] TRA01	QVS212 CG020 [] DHT	250	CG	COG	2 p	±0.1pF, ±0.25pF	840	200	0.85±0.10	
MCARQ219SCG2R2 [] TRA01	QVS212 CG2R2 [] DHT	250	CG	COG	2.2 p	±0.1pF, ±0.25pF	844	200	0.85±0.10	
MCARQ219SCG2R4 [] TRA01	QVS212 CG2R4 [] DHT	250	CG	COG	2.4 p	±0.1pF, ±0.25pF	848	200	0.85±0.10	
MCARQ219SCG2R7 [] TRA01	QVS212 CG2R7 [] DHT	250	CG	COG	2.7 p	±0.1pF, ±0.25pF	854	200	0.85±0.10	
MCARQ219SCG030 [] TRA01	QVS212 CG030 [] DHT	250	CG	COG	3 p	±0.1pF, ±0.25pF	860	200	0.85±0.10	
MCARQ219SCG3R3 [] TRA01	QVS212 CG3R3 [] DHT	250	CG	COG	3.3 p	±0.1pF, ±0.25pF	866	200	0.85±0.10	
MCARQ219SCG3R6 [] TRA01	QVS212 CG3R6 [] DHT	250	CG	COG	3.6 p	±0.1pF, ±0.25pF	872	200	0.85±0.10	
MCARQ219SCG3R9 [] TRA01	QVS212 CG3R9 [] DHT	250	CG	COG	3.9 p	±0.1pF, ±0.25pF	878	200	0.85±0.10	
MCARQ219SCG4R3 [] TRA01	QVS212 CG4R3 [] DHT	250	CG	COG	4.3 p	±0.1pF, ±0.25pF	886	200	0.85±0.10	
MCARQ219SCG4R7 [] TRA01	QVS212 CG4R7 [] DHT	250	CG	COG	4.7 p	±0.1pF, ±0.25pF	894	200	0.85±0.10	
MCARQ219SCG5R1 [] TRA01	QVS212 CG5R1 [] DHT	250	CG	COG	5.1 p	±0.25pF, ±0.5pF	902	200	0.85±0.10	
MCARQ219SCG5R6 [] TRA01	QVS212 CG5R6 [] DHT	250	CG	COG	5.6 p	±0.25pF, ±0.5pF	912	200	0.85±0.10	
MCARQ219SCG6R2 [] TRA01	QVS212 CG6R2 [] DHT	250	CG	COG	6.2 p	±0.25pF, ±0.5pF	924	200	0.85±0.10	
MCARQ219SCG6R8 [] TRA01	QVS212 CG6R8 [] DHT	250	CG	COG	6.8 p	±0.25pF, ±0.5pF	936	200	0.85±0.10	
MCARQ219SCG7R5 [] TRA01	QVS212 CG7R5 [] DHT	250	CG	COG	7.5 p	±0.25pF, ±0.5pF	950	200	0.85±0.10	
MCARQ219SCG8R2 [] TRA01	QVS212 CG8R2 [] DHT	250	CG	COG	8.2 p	±0.25pF, ±0.5pF	964	200	0.85±0.10	
MCARQ219SCG9R1 [] TRA01	QVS212 CG9R1 [] DHT	250	CG	COG	9.1 p	±0.25pF, ±0.5pF	982	200	0.85±0.10	
MCARQ219SCG100JTRA01	QVS212 CG100JDHT	250	CG	COG	10 p	±5%	1000	200	0.85±0.10	
MCARQ219SCG110JTRA01	QVS212 CG110JDHT	250	CG	COG	11 p	±5%	1020	200	0.85±0.10	
MCARQ219SCG120JTRA01	QVS212 CG120JDHT	250	CG	COG	12 p	±5%	1040	200	0.85±0.10	
MCARQ219SCG130JTRA01	QVS212 CG130JDHT	250	CG	COG	13 p	±5%	1060	200	0.85±0.10	
MCARQ219SCG150JTRA01	QVS212 CG150JDHT	250	CG	COG	15 p	±5%	1100	200	0.85±0.10	
MCARQ219SCG160JTRA01	QVS212 CG160JDHT	250	CG	COG	16 p	±5%	1120	200	0.85±0.10	
MCARQ219SCG180JTRA01	QVS212 CG180JDHT	250	CG	COG	18 p	±5%	1160	200	0.85±0.10	
MCARQ219SCG200JTRA01	QVS212 CG200JDHT	250	CG	COG	20 p	±5%	1200	200	0.85±0.10	
MCARQ219SCG220JTRA01	QVS212 CG220JDHT	250	CG	COG	22 p	±5%	1240	200	0.85±0.10	
MCARQ219SCG240JTRA01	QVS212 CG240JDHT	250	CG	COG	24 p	±5%	1280	200	0.85±0.10	
MCARQ219SCG270JTRA01	QVS212 CG270JDHT	250	CG	COG	27 p	±5%	1340	200	0.85±0.10	
MCARQ219SCG300JTRA01	QVS212 CG300JDHT	250	CG	COG	30 p	±5%	1400	200	0.85±0.10	
MCARQ219SCG330JTRA01	QVS212 CG330JDHT	250	CG	COG	33 p	±5%	1400	200	0.85±0.10	
MCARQ219SCG360JTRA01	QVS212 CG360JDHT	250	CG	COG	36 p	±5%	1400	200	0.85±0.10	
MCARQ219SCG390JTRA01	QVS212 CG390JDHT	250	CG	COG	39 p	±5%	1400	200	0.85±0.10	
MCARQ219SCG430JTRA01	QVS212 CG430JDHT	250	CG	COG	43 p	±5%	1400	200	0.85±0.10	
MCARQ219SCG470JTRA01	QVS212 CG470JDHT	250	CG	COG	47 p	±5%	1400	200	0.85±0.10	
MCARQ219SCG510JTRA01	QVS212 CG510JDHT	250	CG	COG	51 p	±5%	1400	200	0.85±0.10	
MCARQ219SCG560JTRA01	QVS212 CG560JDHT	250	CG	COG	56 p	±5%	1400	200	0.85±0.10	
MCARQ219SCG620JTRA01	QVS212 CG620JDHT	250	CG	COG	62 p	±5%	1400	200	0.85±0.10	
MCARQ219SCG680JTRA01	QVS212 CG680JDHT	250	CG	COG	68 p	±5%	1400	200	0.85±0.10	
MCARQ219SCG750JTRA01	QVS212 CG750JDHT	250	CG	COG	75 p	±5%	1400	200	0.85±0.10	
MCARQ219SCG820JTRA01	QVS212 CG820JDHT	250	CG	COG	82 p	±5%	1400	200	0.85±0.10	
MCARQ219SCG910JTRA01	QVS212 CG910JDHT	250	CG	COG	91 p	±5%	1400	200	0.85±0.10	
MCARQ219SCG101JTRA01	QVS212 CG101JDHT	250	CG	COG	100 p	±5%	1400	200	0.85±0.10	

▶由于篇幅有限,本产品目录中只记载了有代表性的产品规格,若考虑使用敝公司产品时,请确认交货规格说明书中的详细规格。另外,有关各产品的详细信息(特性图、可靠性信息、使用时的注意事项等),请参阅敝公司网站(<http://www.ty-top.com/>)。

■型号一览

车载(车身系/情报系)用途 树脂外部电极多层陶瓷电容器

●1608规格

【温度特性 B7 : X7R (-55~+125℃)】 0.8mm厚度

新型号	旧型号(参考用)	额定电压 [V]	温度特性		静电容量 [F]	静电容量允许偏差[%]	tan δ [%]	高温负载		厚度*1 [mm]	注释
								额定电压 x %			
MCJCT168BB7473 [TPA01]	TMJ107BB7473 [AHT]	25		X7R	0.047 μ	±10, ±20	3.5	200		0.8+0.20/-0	
MCJCT168BB7104 [TPA01]	TMJ107BB7104 [AHT]	25		X7R	0.1 μ	±10, ±20	3.5	200		0.8+0.20/-0	
MGJCT168BB7224 [TPA01]	TMJ107BB7224 [AHT]	25		X7R	0.22 μ	±10, ±20	10	150		0.8+0.20/-0	
MCJCT168BB7474 [TPA01]	TMJ107BB7474 [AHT]	25		X7R	0.47 μ	±10, ±20	10	150		0.8+0.20/-0	
MCJCT168CB7105 [RPA01]	TMJ107CB7105 [AHR]	25		X7R	1 μ	±10, ±20	10	150		0.8+0.25/-0	
MCJCG168BB7473 [TPA01]	GMJ107BB7473 [AHT]	35		X7R	0.047 μ	±10, ±20	3.5	200		0.8+0.20/-0	
MCJCG168BB7104 [TPA01]	GMJ107BB7104 [AHT]	35		X7R	0.1 μ	±10, ±20	3.5	200		0.8+0.20/-0	
MCJCG168BB7224 [TPA01]	GMJ107BB7224 [AHT]	35		X7R	0.22 μ	±10, ±20	10	150		0.8+0.20/-0	
MCJCG168BB7474 [TPA01]	GMJ107BB7474 [AHT]	35		X7R	0.47 μ	±10, ±20	10	150		0.8+0.20/-0	
MCJCG168CB7105 [RPA01]	GMJ107CB7105 [AHR]	35		X7R	1 μ	±10, ±20	10	150		0.8+0.25/-0	
MCJCU168AB7102 [TPA01]	UMJ107AB7102 [AHT]	50		X7R	1000 p	±10, ±20	3.5	200		0.8+0.15/-0.05	
MCJCU168AB7222 [TPA01]	UMJ107AB7222 [AHT]	50		X7R	2200 p	±10, ±20	3.5	200		0.8+0.15/-0.05	
MCJCU168BB7472 [TPA01]	UMJ107BB7472 [AHT]	50		X7R	4700 p	±10, ±20	3.5	200		0.8+0.20/-0	
MCJCU168BB7103 [TPA01]	UMJ107BB7103 [AHT]	50		X7R	0.01 μ	±10, ±20	3.5	200		0.8+0.20/-0	
MCJCU168BB7223 [TPA01]	UMJ107BB7223 [AHT]	50		X7R	0.022 μ	±10, ±20	3.5	200		0.8+0.20/-0	
MCJCU168BB7473 [TPA01]	UMJ107BB7473 [AHT]	50		X7R	0.047 μ	±10, ±20	3.5	200		0.8+0.20/-0	
MCJCU168BB7104 [TPA01]	UMJ107BB7104 [AHT]	50		X7R	0.1 μ	±10, ±20	3.5	200		0.8+0.20/-0	
MCJCH168AB7102 [TPA01]	HMJ107AB7102 [AHT]	100		X7R	1000 p	±10, ±20	3.5	200		0.8+0.15/-0.05	
MCJCH168AB7222 [TPA01]	HMJ107AB7222 [AHT]	100		X7R	2200 p	±10, ±20	3.5	200		0.8+0.15/-0.05	
MCJCH168BB7472 [TPA01]	HMJ107BB7472 [AHT]	100		X7R	4700 p	±10, ±20	3.5	200		0.8+0.20/-0	
MCJCH168BB7103 [TPA01]	HMJ107BB7103 [AHT]	100		X7R	0.01 μ	±10, ±20	3.5	200		0.8+0.20/-0	
MCJCH168BB7223 [TPA01]	HMJ107BB7223 [AHT]	100		X7R	0.022 μ	±10, ±20	3.5	200		0.8+0.20/-0	
MCJCH168BB7473 [TPA01]	HMJ107BB7473 [AHT]	100		X7R	0.047 μ	±10, ±20	3.5	200		0.8+0.20/-0	
MCJCH168BB7104 [TPA01]	HMJ107BB7104 [AHT]	100		X7R	0.1 μ	±10, ±20	3.5	200		0.8+0.20/-0	

●2012规格

【温度特性 B7 : X7R (-55~+125℃), C7 : X7S (-55~+125℃)】 0.85mm厚度 (D)、1.25mm厚度 (G)

新型号	旧型号(参考用)	额定电压 [V]	温度特性		静电容量 [F]	静电容量允许偏差[%]	tan δ [%]	高温负载		厚度*1 [mm]	注释
								额定电压 x %			
MCJJC21GCB7106 [TPA01]	UMJ212CB7106 [GHT]	6.3		X7R	10 μ	±10, ±20	10	150		1.25+0.25/-0	
MGJGE21GCB7225 [TPA01]	EMJ212CB7225 [GHT]	16		X7R	2.2 μ	±10, ±20	10	150		1.25+0.25/-0	
MCJGE21GCB7475 [TPA01]	EMJ212CB7475 [GHT]	16		X7R	4.7 μ	±10, ±20	10	150		1.25+0.25/-0	
MCJCT21GCB7225 [TPA01]	TMJ212CB7225 [GHT]	25		X7R	2.2 μ	±10, ±20	10	150		1.25+0.25/-0	
MCJCG21GCB7105 [TPA01]	GMJ212CB7105 [GHT]	35		X7R	1 μ	±10, ±20	10	150		1.25+0.25/-0	
MCJCU21GCB7103 [TPA01]	UMJ212BB7103 [GHT]	50		X7R	0.01 μ	±10, ±20	3.5	200		1.25+0.20/-0	
MCJCU21GCB7223 [TPA01]	UMJ212BB7223 [GHT]	50		X7R	0.022 μ	±10, ±20	3.5	200		1.25+0.20/-0	
MGJCU21GCB7473 [TPA01]	UMJ212BB7473 [GHT]	50		X7R	0.047 μ	±10, ±20	3.5	200		1.25+0.20/-0	
MCJCU21GCB7104 [TPA01]	UMJ212BB7104 [GHT]	50		X7R	0.1 μ	±10, ±20	3.5	200		1.25+0.20/-0	
MCJCU21GCB7224 [TPA01]	UMJ212BB7224 [GHT]	50		X7R	0.22 μ	±10, ±20	3.5	200		1.25+0.20/-0	
MCJCU21GCC7474 [TDA01]	UMJ212CC7474 [GHTE]	50		X7S	0.47 μ	±10, ±20	3.5	150		1.25+0.25/-0	
MCJCU21GCB7105 [TPA01]	UMJ212CB7105 [GHT]	50		X7R	1 μ	±10, ±20	10	150		1.25+0.25/-0	
MCJCH219NB7102 [TPA01]	HMJ212KB7102 [DHT]	100		X7R	1000 p	±10, ±20	3.5	200		0.85±0.15	
MCJCH219NB7222 [TPA01]	HMJ212KB7222 [DHT]	100		X7R	2200 p	±10, ±20	3.5	200		0.85±0.15	
MCJCH219NB7472 [TPA01]	HMJ212KB7472 [DHT]	100		X7R	4700 p	±10, ±20	3.5	200		1.25+0.20/-0	
MCJCH219NB7103 [TPA01]	HMJ212KB7103 [DHT]	100		X7R	0.01 μ	±10, ±20	3.5	200		1.25+0.20/-0	
MCJCH219NB7223 [TPA01]	HMJ212KB7223 [DHT]	100		X7R	0.022 μ	±10, ±20	3.5	200		1.25+0.20/-0	
MCJCH219NB7473 [TPA01]	HMJ212KB7473 [DHT]	100		X7R	0.047 μ	±10, ±20	3.5	200		1.25+0.20/-0	
MGJCH219NB7104 [TPA01]	HMJ212KB7104 [DHT]	100		X7R	0.1 μ	±10, ±20	3.5	200		1.25+0.20/-0	
MCJCH219NB7224 [TPA01]	HMJ212KB7224 [DHT]	100		X7R	0.22 μ	±10, ±20	3.5	200		1.25+0.20/-0	
MCJCH219NB7474 [TDA01]	HMJ212CC7474 [GHTE]	100		X7S	0.47 μ	±10, ±20	3.5	150		1.25+0.25/-0	
MCJCH219NB7105 [TDA01]	HMJ212CC7105 [GHTE]	100		X7S	1 μ	±10, ±20	3.5	150		1.25+0.30/-0	
MCJQ219NB7102 [TPA01]	QMJ212KB7102 [DHT]	250		X7R	1000 p	±10, ±20	2.5	150		0.85±0.15	
MGJQ219NB7222 [TPA01]	QMJ212KB7222 [DHT]	250		X7R	2200 p	±10, ±20	2.5	150		0.85±0.15	
MCJQ219NB7472 [TPA01]	QMJ212KB7472 [DHT]	250		X7R	4700 p	±10, ±20	2.5	150		1.25+0.20/-0	
MCJQ219NB7103 [TPA01]	QMJ212KB7103 [DHT]	250		X7R	0.01 μ	±10, ±20	2.5	150		1.25+0.20/-0	
MCJQ219NB7223 [TPA01]	QMJ212KB7223 [DHT]	250		X7R	0.022 μ	±10, ±20	2.5	150		1.25+0.20/-0	

▶ 由于篇幅有限, 本产品目录中只记载了有代表性的产品规格, 若考虑使用敝公司产品时, 请确认交货规格说明书中的详细规格。另外, 有关各产品的详细信息(特性图、可靠性信息、使用时的注意事项等), 请参阅敝公司网站(<http://www.ty-top.com/>)。

■型号一览

●3216规格

【温度特性 B7 : X7R (-55~+125°C), C7 : X7S (-55~+125°C)】 1.15mm厚度、1.6mm厚度

新型号	旧型号(参考用)	额定电压 [V]	温度特性	静电容量 [F]	静电容量允许偏差 [%]	tan δ [%]	高温负载		厚度*1 [mm]	注释
							额定电压 x %			
MCJCL31BB7226 [] TPA01	LMJ316BB7226 [] LHT	10	X7R	22 μ	±10, ±20	10	150		1.6±0.30	
MCJCE31LB7475 [] TPA01	EMJ316BB7475 [] LHT	16	X7R	4.7 μ	±10, ±20	10	150		1.6±0.30	
MCJCE31LB7106 [] TPA01	EMJ316BB7106 [] LHT	16	X7R	10 μ	±10, ±20	10	150		1.6±0.30	
MCJCT31LB7474 [] TPA01	TMJ316BB7474 [] LHT	25	X7R	0.47 μ	±10, ±20	3.5	200		1.6±0.30	
MCJCT31LB7475 [] TPA01	TMJ316BB7475 [] LHT	25	X7R	4.7 μ	±10, ±20	10	150		1.6±0.30	
MCJCT31LB7106 [] TPA01	TMJ316BB7106 [] LHT	25	X7R	10 μ	±10, ±20	10	150		1.6±0.30	
MCJCG31LB7474 [] TPA01	GMJ316BB7474 [] LHT	35	X7R	0.47 μ	±10, ±20	3.5	200		1.6±0.30	
MCJCG31LB7225 [] TPA01	GMJ316BB7225 [] LHT	35	X7R	2.2 μ	±10, ±20	10	150		1.6±0.20	
MCJCG31LB7475 [] TPA01	GMJ316BB7475 [] LHT	35	X7R	4.7 μ	±10, ±20	10	150		1.6±0.30	
MCJCG31LB7106 [] TPA01	GMJ316BB7106 [] LHT	35	X7R	10 μ	±10, ±20	10	150		1.6±0.30	
MCJCU31LB7473 [] TPA01	UMJ316BB7473 [] LHT	50	X7R	0.047 μ	±10, ±20	3.5	200		1.6±0.30	
MCJCU31LB7104 [] TPA01	UMJ316BB7104 [] LHT	50	X7R	0.1 μ	±10, ±20	3.5	200		1.6±0.30	
MCJCU31LB7224 [] TPA01	UMJ316BB7224 [] LHT	50	X7R	0.22 μ	±10, ±20	3.5	200		1.6±0.30	
MCJCU31LB7474 [] TPA01	UMJ316BB7474 [] LHT	50	X7R	0.47 μ	±10, ±20	3.5	200		1.6±0.30	
MCJCU31LB7105 [] TPA01	UMJ316BB7105 [] LHT	50	X7R	1 μ	±10, ±20	3.5	200		1.6±0.30	
MCJCU31LB7225 [] TPA01	UMJ316AB7225 [] LHT	50	X7R	2.2 μ	±10, ±20	10	150		1.6±0.20	
MCJCU31LB7475 [] TDA01	UMJ316BC7475 [] LHTE	50	X7S	4.7 μ	±10, ±20	2.5	150		1.6±0.30	
MCJCH31QHB7102 [] TPA01	HMJ316 B7102 [] FHT	100	X7R	1000 p	±10, ±20	3.5	200		1.15±0.10	
MCJCH31QHB7222 [] TPA01	HMJ316 B7222 [] FHT	100	X7R	2200 p	±10, ±20	3.5	200		1.15±0.10	
MCJCH31QHB7472 [] TPA01	HMJ316 B7472 [] FHT	100	X7R	4700 p	±10, ±20	3.5	200		1.15±0.10	
MCJCH31QAB7103 [] TPA01	HMJ316KB7103 [] FHT	100	X7R	0.01 μ	±10, ±20	3.5	200		1.15±0.20	
MCJCH31LB7223 [] TPA01	HMJ316BB7223 [] LHT	100	X7R	0.022 μ	±10, ±20	3.5	200		1.6±0.30	
MCJCH31LB7473 [] TPA01	HMJ316BB7473 [] LHT	100	X7R	0.047 μ	±10, ±20	3.5	200		1.6±0.30	
MCJCH31LB7104 [] TPA01	HMJ316BB7104 [] LHT	100	X7R	0.1 μ	±10, ±20	3.5	200		1.6±0.30	
MCJCH31LB7224 [] TPA01	HMJ316BB7224 [] LHT	100	X7R	0.22 μ	±10, ±20	3.5	200		1.6±0.30	
MCJCH31LB7474 [] TPA01	HMJ316BB7474 [] LHT	100	X7R	0.47 μ	±10, ±20	3.5	200		1.6±0.30	
MCJCH31LB7105 [] TPA01	HMJ316BB7105 [] LHT	100	X7R	1 μ	±10, ±20	3.5	200		1.6±0.30	
MCJCH31LB7225 [] TDA01	HMJ316BC7225 [] LHTE	100	X7S	2.2 μ	±10, ±20	3.5	150		1.6±0.30	
MCJCG31QHB7102 [] TPA01	QMJ316 B7102 [] FHT	250	X7R	1000 p	±10, ±20	2.5	150		1.15±0.10	
MCJCG31QHB7222 [] TPA01	QMJ316 B7222 [] FHT	250	X7R	2200 p	±10, ±20	2.5	150		1.15±0.10	
MCJCG31QHB7472 [] TPA01	QMJ316 B7472 [] FHT	250	X7R	4700 p	±10, ±20	2.5	150		1.15±0.10	
MCJCG31QAB7103 [] TPA01	QMJ316KB7103 [] FHT	250	X7R	0.01 μ	±10, ±20	2.5	150		1.15±0.20	
MCJCG31LB7223 [] TPA01	QMJ316BB7223 [] LHT	250	X7R	0.022 μ	±10, ±20	2.5	150		1.6±0.30	
MCJCG31LB7473 [] TPA01	QMJ316BB7473 [] LHT	250	X7R	0.047 μ	±10, ±20	2.5	150		1.6±0.30	
MCJCG31LB7104 [] TPA01	QMJ316BB7104 [] LHT	250	X7R	0.1 μ	±10, ±20	2.5	150		1.6±0.30	
MCJCS31QHB7102 [] TPA01	SMJ316 B7102 [] FHT	630	X7R	1000 p	±10, ±20	2.5	120		1.15±0.10	
MCJCS31QHB7222 [] TPA01	SMJ316 B7222 [] FHT	630	X7R	2200 p	±10, ±20	2.5	120		1.15±0.10	
MCJCS31QHB7472 [] TPA01	SMJ316 B7472 [] FHT	630	X7R	4700 p	±10, ±20	2.5	120		1.15±0.10	
MCJCS31QAB7103 [] TPA01	SMJ316KB7103 [] FHT	630	X7R	0.01 μ	±10, ±20	2.5	120		1.15±0.20	
MCJCS31LB7223 [] TPA01	SMJ316BB7223 [] LHT	630	X7R	0.022 μ	±10, ±20	2.5	120		1.6±0.30	

●3225规格

【温度特性 B7 : X7R (-55~+125°C), C7 : X7S (-55~+125°C)】 1.9mm厚度、2.5mm厚度

新型号	旧型号(参考用)	额定电压 [V]	温度特性	静电容量 [F]	静电容量允许偏差 [%]	tan δ [%]	高温负载		厚度*1 [mm]	注释
							额定电压 x %			
MCJCG32MLB7476 [] PPD1	JMJ325KB7476 [] MHP	6.3	X7R	47 μ	±10, ±20	10	150		2.5±0.30	
MCJCE32MLB7226 [] PPD1	EMJ325KB7226 [] MHP	16	X7R	22 μ	±10, ±20	10	150		2.5±0.30	
MCJCT32MAB7475 [] PPA01	TMJ325AB7475 [] MHP	25	X7R	4.7 μ	±10, ±20	5	150		2.5±0.30	
MCJCT32MLB7106 [] PPD1	TMJ325KB7106 [] MHP	25	X7R	10 μ	±10, ±20	10	150		2.5±0.30	
MCJCG32MAB7475 [] PPA01	GMJ325AB7475 [] MHP	35	X7R	4.7 μ	±10, ±20	5	150		2.5±0.30	
MCJCG32MLB7106 [] PPD1	GMJ325KB7106 [] MHP	35	X7R	10 μ	±10, ±20	10	150		2.5±0.30	
MCJCU32MAB7225 [] PPA01	UMJ325AB7225 [] MHP	50	X7R	2.2 μ	±10, ±20	3.5	200		2.5±0.30	
MCJCU32MAB7475 [] PPA01	UMJ325AB7475 [] MHP	50	X7R	4.7 μ	±10, ±20	5	150		2.5±0.30	
MCJCU32MLB7106 [] PPD1	UMJ325KB7106 [] MHP	50	X7R	10 μ	±10, ±20	10	150		2.5±0.30	
MCJCH32NSB7223 [] TPA01	HMJ325 B7223 [] NHT	100	X7R	0.022 μ	±10, ±20	3.5	200		1.9±0.20	
MCJCH32NSB7473 [] TPA01	HMJ325 B7473 [] NHT	100	X7R	0.047 μ	±10, ±20	3.5	200		1.9±0.20	
MCJCH32NSB7104 [] TPA01	HMJ325 B7104 [] NHT	100	X7R	0.1 μ	±10, ±20	3.5	200		1.9±0.20	
MCJCH32NSB7224 [] TPA01	HMJ325 B7224 [] NHT	100	X7R	0.22 μ	±10, ±20	3.5	200		1.9±0.20	
MCJCH32NSB7474 [] TPA01	HMJ325 B7474 [] NHT	100	X7R	0.47 μ	±10, ±20	3.5	200		1.9±0.20	
MCJCH32NSB7105 [] TPA01	HMJ325 B7105 [] NHT	100	X7R	1 μ	±10, ±20	3.5	200		1.9±0.20	
MCJCH32MAB7225 [] PPA01	HMJ325AB7225 [] MHP	100	X7R	2.2 μ	±10, ±20	3.5	200		2.5±0.30	
MCJCH32MLC7475 [] PPD1	HMJ325KC7475 [] MHPE	100	X7S	4.7 μ	±10, ±20	3.5	150		2.5±0.30	
MCJCG32NSB7223 [] TPA01	QMJ325 B7223 [] NHT	250	X7R	0.022 μ	±10, ±20	2.5	150		1.9±0.20	
MCJCG32NSB7473 [] TPA01	QMJ325 B7473 [] NHT	250	X7R	0.047 μ	±10, ±20	2.5	150		1.9±0.20	
MCJCG32NSB7104 [] TPA01	QMJ325 B7104 [] NHT	250	X7R	0.1 μ	±10, ±20	2.5	150		1.9±0.20	
MCJCG32NSB7224 [] TPA01	QMJ325 B7224 [] NHT	250	X7R	0.22 μ	±10, ±20	2.5	150		1.9±0.20	
MCJCS32NSB7223 [] TPA01	SMJ325 B7223 [] NHT	630	X7R	0.022 μ	±10, ±20	2.5	120		1.9±0.20	
MCJCS32NSB7473 [] TPA01	SMJ325 B7473 [] NHT	630	X7R	0.047 μ	±10, ±20	2.5	120		1.9±0.20	

▶ 由于篇幅有限, 本产品目录中只记载了有代表性的产品规格, 若考虑使用敝公司产品时, 请确认交货规格说明书中的详细规格。另外, 有关各产品的详细信息(特性图、可靠性信息、使用时的注意事项等), 请参阅敝公司网站(<http://www.ty-top.com/>)。

车载用(车身系)信息系

多层陶瓷电容器

■ 型号一览

车载(车身系/情报系)用途 LW反转/低 ESL多层陶瓷电容器(LWDC™)

● 0510规格

【温度特性 B5 (BJ) : X5R (-55~+85°C)】 0.3mm厚度

新型号	旧型号(参考用)	额定电压 [V]	温度特性	静电容量 [F]	静电容量允许偏差 [%]	tan δ [%]	高温负载		厚度*1 [mm]	注释
							额定电压 x %			
MCRLT103SB5104MFNA01	TWK105 BJ104MPHF	25	X5R	0.1 μ	±20	5	150	0.3±0.05		
MCRLT103SB5224MFNA01	EWK105 BJ224MPHF	16	X5R	0.22 μ	±20	10	150	0.3±0.05		
MCRLT103SB5474MFNA01	LWK105 BJ474MPHF	10	X5R	0.47 μ	±20	10	150	0.3±0.05		
MCRLA103SB5105MFNA01	AWK105 BJ105MPHF	4	X5R	1 μ	±20	10	150	0.3±0.05		

【温度特性 C6 : X6S (-55~+105°C), C7 : X7S (-55~+125°C)】 0.3mm厚度

新型号	旧型号(参考用)	额定电压 [V]	温度特性	静电容量 [F]	静电容量允许偏差 [%]	tan δ [%]	高温负载		厚度*1 [mm]	注释
							额定电压 x %			
MCRLT103SC6104MFNA01	EWK105 C6104MPHF	16	X6S	0.1 μ	±20	5	150	0.3±0.05		
MCRLT103SC7104MFNA01	LWK105 C7104MPHF	10	X7S	0.1 μ	±20	5	150	0.3±0.05		
MCRLT103SC6224MFNA01	LWK105 C6224MPHF	10	X6S	0.22 μ	±20	10	150	0.3±0.05		
MCRLJ103SC7104MFNA01	JWK105 C7104MPHF	6.3	X7S	0.1 μ	±20	5	150	0.3±0.05		
MCRLJ103SC7224MFNA01	JWK105 C7224MPHF	6.3	X7S	0.22 μ	±20	10	150	0.3±0.05		
MCRLJ103SC6474MFNA01	JWK105 C6474MPHF	6.3	X6S	0.47 μ	±20	10	150	0.3±0.05		
MCRLA103SC7224MFNA01	AWK105 C7224MPHF	4	X7S	0.22 μ	±20	10	150	0.3±0.05		
MCRLA103SC6474MFNA01	AWK105 C6474MPHF	4	X6S	0.47 μ	±20	10	150	0.3±0.05		

● 0816规格

【温度特性 B5 (BJ) : X5R (-55~+85°C)】 0.5mm厚度

新型号	旧型号(参考用)	额定电压 [V]	温度特性	静电容量 [F]	静电容量允许偏差 [%]	tan δ [%]	高温负载		厚度*1 [mm]	注释
							额定电压 x %			
MCRLT165SB5105MTNA01	LWK107 BJ105MVHT	10	X5R	1 μ	±20	10	150	0.5±0.05		
MCRLJ165SB5225MTNA01	JWK107 BJ225MVHT	6.3	X5R	2.2 μ	±20	10	150	0.5±0.05		
MCRLJ165SB5475MTNA01	JWK107 BJ475MVHT	6.3	X5R	4.7 μ	±20	10	150	0.5±0.05		

【温度特性 B7 : X7R (-55~+125°C), C6 : X6S (-55~+105°C), C7 : X7S (-55~+125°C)】 0.5mm厚度

新型号	旧型号(参考用)	额定电压 [V]	温度特性	静电容量 [F]	静电容量允许偏差 [%]	tan δ [%]	高温负载		厚度*1 [mm]	注释
							额定电压 x %			
MCRLT165SB7104MTNA01	TWK107 B7104MVHT	25	X7R	0.1 μ	±20	5	150	0.5±0.05		
MCRLT165SB7224MTNA01	EWK107 B7224MVHT	16	X7R	0.22 μ	±20	5	150	0.5±0.05		
MCRLT165SB7474MTNA01	EWK107 B7474MVHT	16	X7R	0.47 μ	±20	5	150	0.5±0.05		
MCRLT165SB7474MTNA01	LWK107 B7474MVHT	10	X7R	0.47 μ	±20	5	150	0.5±0.05		
MCRLJ165SC7105MTNA01	JWK107 C7105MVHT	6.3	X7S	1 μ	±20	10	150	0.5±0.05		
MCRLA165SC6225MTNA01	AWK107 C6225MVHT	4	X6S	2.2 μ	±20	10	150	0.5±0.05		
MCRLA165SC6475MTNA01	AWK107 C6475MVHT	4	X6S	4.7 μ	±20	10	150	0.5±0.05		

● 1220规格

【温度特性 B5 (BJ) : X5R (-55~+85°C)】 0.85mm厚度

新型号	旧型号(参考用)	额定电压 [V]	温度特性	静电容量 [F]	静电容量允许偏差 [%]	tan δ [%]	高温负载		厚度*1 [mm]	注释
							额定电压 x %			
MCRLT219SB5475[]TNA01	LWK212 BJ475[]DHT	10	X5R	4.7 μ	±10, ±20	10	150	0.85±0.10		
MCRLJ219SB5106MTNA01	JWK212 BJ106MDHT	6.3	X5R	10 μ	±20	10	150	0.85±0.10		
MCRLA219SB5226MTNA01	AWK212 BJ226MDHT	4	X5R	22 μ	±20	10	150	0.85±0.10		

【温度特性 C6 : X6S (-55~+105°C)】 0.85mm厚度

新型号	旧型号(参考用)	额定电压 [V]	温度特性	静电容量 [F]	静电容量允许偏差 [%]	tan δ [%]	高温负载		厚度*1 [mm]	注释
							额定电压 x %			
MCRLJ219SC6475[]TNA01	JWK212 C6475[]DHT	6.3	X6S	4.7 μ	±10, ±20	10	150	0.85±0.10		

▶ 由于篇幅有限, 本产品目录中只记载了有代表性的产品规格, 若考虑使用敝公司产品时, 请确认交货规格说明书中的详细规格。
另外, 有关各产品的详细信息(特性图、可靠性信息、使用时的注意事项等), 请参阅敝公司网站(<http://www.ty-top.com/>)。

Multilayer Ceramic Capacitors

PACKAGING

① Minimum Quantity

● Taped package

Type			Thickness		Standard Quantity [pcs]	
Code	JIS(mm)	EIA(inch)	[mm]	Code	Paper tape	Embossed tape
02	0201	008004	0.125	1	—	50000
04	0402	01005	0.2	2	—	40000
06	0603	0201	0.3	3	15000	—
1L	1005	0402	0.13	H	—	20000
			0.18	E	—	15000
			0.2	2	20000	—
			0.3	3	15000	—
10	1005	0402	0.5	5	10000	—
	0510 ※	0204	0.3	3	10000	—
16	1608	0603	0.45	K	4000	—
			0.7	7		
			0.8	8		
			0.8	8	3000 (Soft Termination)	3000 (Soft Termination)
	0816 ※	0306	0.5	5	—	4000
21	2012	0805	0.85	9	4000	—
			1.25	G	—	3000
			1.25	G	—	2000 (Soft Termination)
	1220 ※	0508	0.85	9	4000	—
31	3216	1206	0.85	9	4000	—
			1.15	Q	—	3000
			1.6	L	—	2000
32	3225	1210	0.85	9	—	2000
			1.15	Q		
			1.9	N		
			2.0 max	Y		
			2.5	M	—	500(T), 1000(P)
45	4532	1812	2.0 max	Y	—	1000
			2.5	M	—	500

注: ※LW Reverse type (MSRL, MCRL, MBRL, MLRL, MMRL)

② Taping material

※ No bottom tape for pressed carrier tape

- Card board carrier tape
- Embossed tape

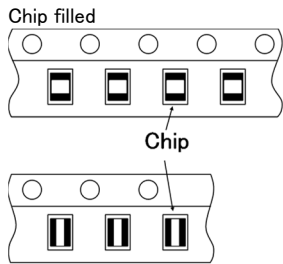
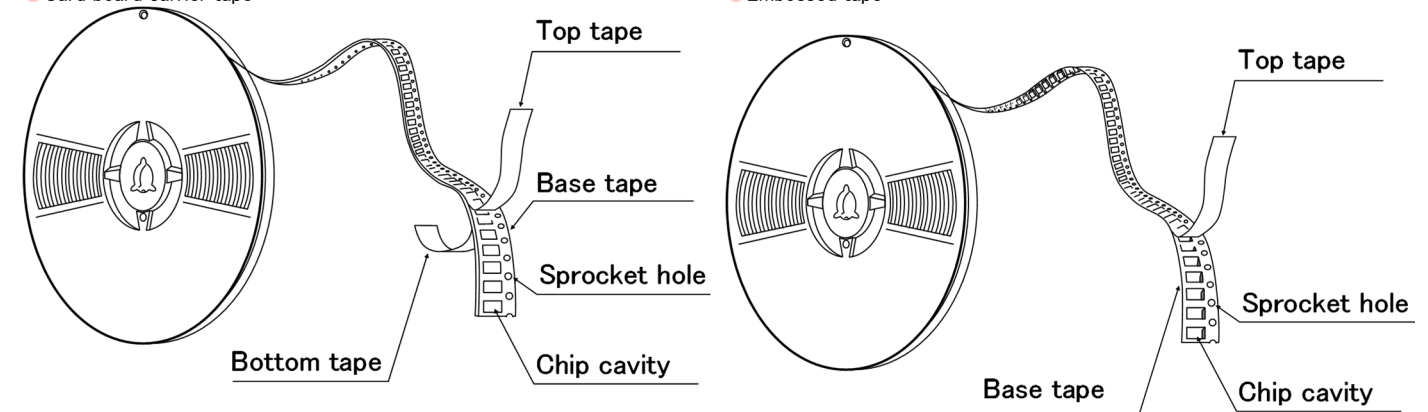

※ LW Reverse type.

③ Representative taping dimensions

● Paper Tape (8mm wide)

● Pressed carrier tape (2mm pitch)

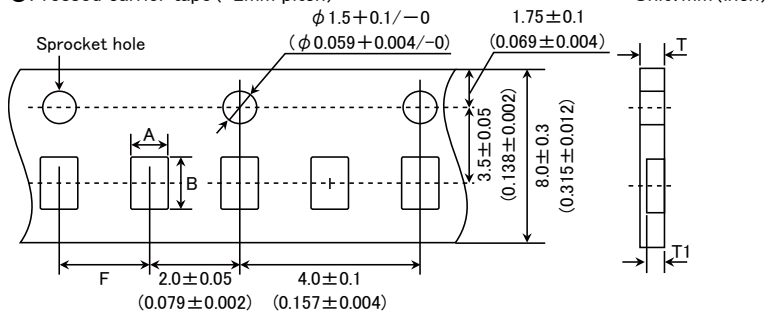

Type(EIA)	Chip Cavity		Insertion Pitch F	Tape Thickness	
	A	B		T	T1
0603 (0201)	0.37	0.67	2.0±0.05	0.45max.	0.42max.
0510 (0204) ※	0.65	1.15		0.4max.	0.3max.
1005 (0402) (*1 2)				0.45max.	0.42max.
1005 (0402) (*1 3)					

Note *1 Thickness, 2:0.2mm, 3:0.3mm. ※ LW Reverse type.

Unit: mm

● Punched carrier tape (2mm pitch)

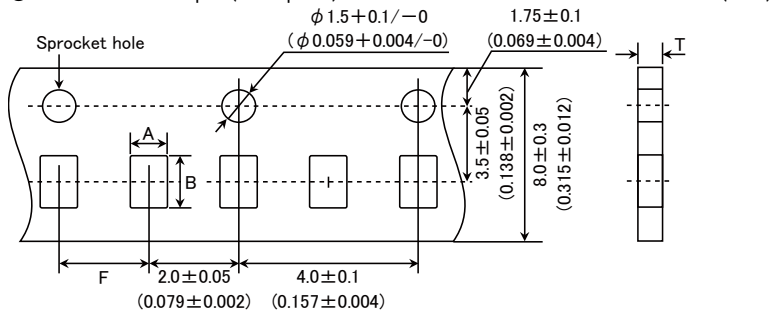

Type(EIA)	Chip Cavity		Insertion Pitch F	Tape Thickness
	A	B		T
1005 (0402)	0.65	1.15	2.0±0.05	0.8max.

Unit: mm

► This catalog contains the typical specification only due to the limitation of space. When you consider the purchase of our products, please check our specification. For details of each product (characteristics graph, reliability information, precautions for use, and so on), see our Web site (<http://www.ty-top.com/>).

● Punched carrier tape (4mm pitch)

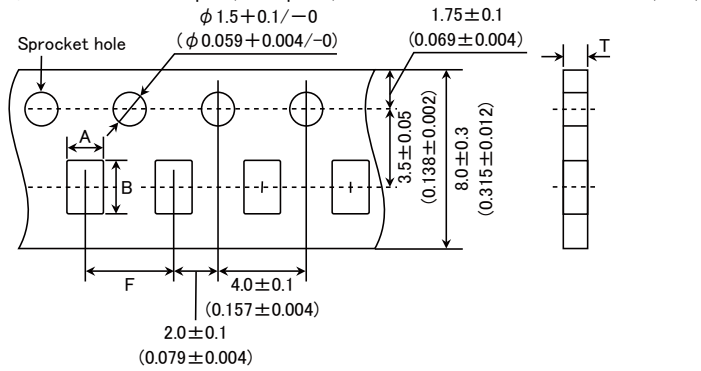

Type(EIA)	Chip Cavity		Insertion Pitch F	Tape Thickness	
	A	B		K	T
1608 (0603)	1.0	1.8	4.0 ± 0.1	1.1max.	1.1max.
0816 (0306) ※					
2012 (0805)					
1220 (0508) ※	1.65	2.4	4.0 ± 0.1	1.1max.	1.1max.
3216 (1206)	2.0	3.6			

Note: Taping size might be different depending on the size of the product. ※ LW Reverse type.

Unit: mm

● Embossed tape (4mm wide)

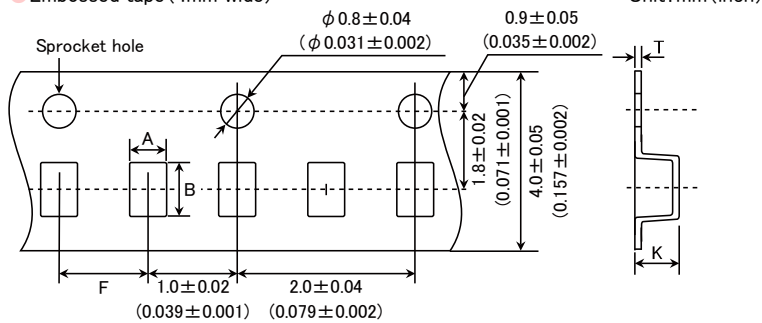

Type(EIA)	Chip Cavity		Insertion Pitch F	Tape Thickness	
	A	B		K	T
0201 (008004)	0.135	0.27	1.0 ± 0.02	0.5max.	0.25max.
0402 (01005)	0.23	0.43			

Unit: mm

● Embossed tape (8mm wide)

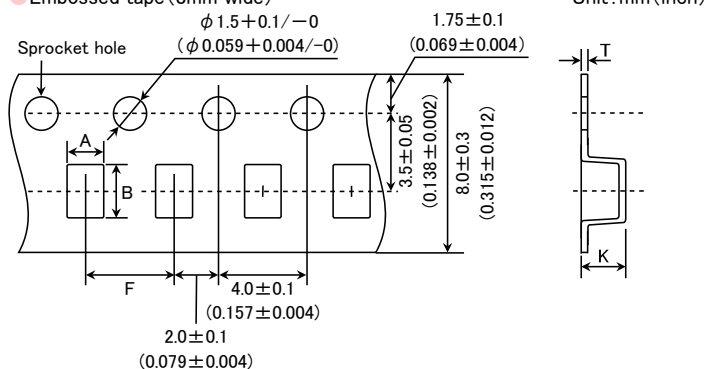

Type(EIA)	Chip Cavity		Insertion Pitch F	Tape Thickness	
	A	B		K	T
1005 (0402)	0.6	1.1	2.0 ± 0.1	0.6max	0.2 ± 0.1
0816 (0306) ※	1.0	1.8	4.0 ± 0.1	1.3max.	0.25 ± 0.1
2012 (0805)	1.65	2.4			
3216 (1206)	2.0	3.6			
3225 (1210)	2.8	3.6	4.0 ± 0.1	3.4max.	0.6max.

Note: ※ LW Reverse type.

Unit: mm

► This catalog contains the typical specification only due to the limitation of space. When you consider the purchase of our products, please check our specification. For details of each product (characteristics graph, reliability information, precautions for use, and so on), see our Web site (<http://www.ty-top.com/>).

● Embossed tape (12mm wide) Unit: mm (inch)

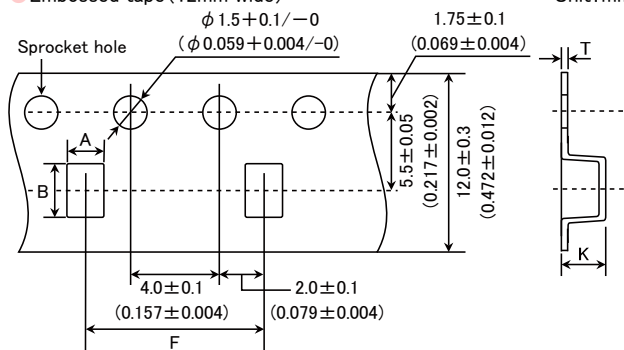

Type(EIA)	Chip Cavity		Insertion Pitch	Tape Thickness	
	A	B		K	T
3225 (1210)	3.1	4.0	8.0±0.1	4.0max.	0.6max.
4532 (1812)	3.7	4.9	8.0±0.1	4.0max.	0.6max.

Unit: mm

④ Trailer and Leader

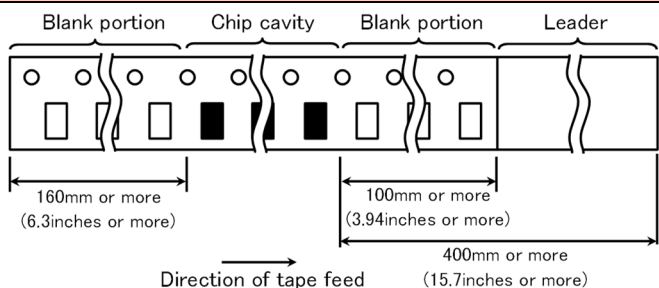

⑤ Reel size

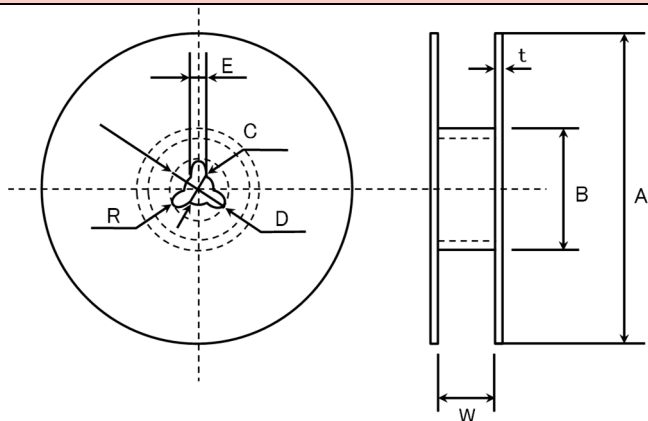

A	B	C	D	E	R
φ178±2.0	φ50min.	φ13.0±0.2	φ21.0±0.8	2.0±0.5	1.0

	T	W
4mm wide tape	1.5max.	5±1.0
8mm wide tape	2.5max.	10±1.5
12mm wide tape	2.5max.	14±1.5

Unit: mm

⑥ Top Tape Strength

The top tape requires a peel-off force of 0.1 to 0.7N in the direction of the arrow as illustrated below.

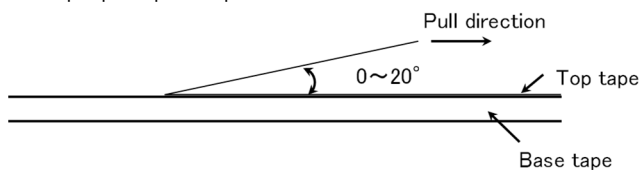

▶ This catalog contains the typical specification only due to the limitation of space. When you consider the purchase of our products, please check our specification. For details of each product (characteristics graph, reliability information, precautions for use, and so on), see our Web site (<http://www.ty-top.com/>).

Multilayer Ceramic Capacitors for Automotive Body & Chassis and Infotainment

RELIABILITY DATA

1. Operating Temperature Range

Specified Value	Temperature Compensating (Class1)	-55 to +125°C		
	High Permittivity (Class2)		Specification	Temperature Range
		B5	X5R	-55 to +85°C
		B7	X7R	-55 to +125°C
		C6	X6S	-55 to +105°C
		C7	X7S	-55 to +125°C
D7	X7T	-55 to +125°C		

2. Storage Conditions

Specified Value	Temperature Compensating (Class1)	-55 to +125°C		
	High Permittivity (Class2)		Specification	Temperature Range
		B5	X5R	-55 to +85°C
		B7	X7R	-55 to +125°C
		C6	X6S	-55 to +105°C
		C7	X7S	-55 to +125°C
D7	X7T	-55 to +125°C		

3. Rated Voltage

Specified Value	Temperature Compensating (Class1)	Standard	50VDC, 25VDC
		High Frequency Type	250VDC
	High Permittivity (Class2)	630VDC, 250VDC, 100VDC 50VDC, 35VDC, 25VDC, 16VDC, 10VDC, 6.3VDC, 4VDC	

4. Withstanding Voltage (Between terminals)

Specified Value	Temperature Compensating (Class1)	No breakdown or damage	
	High Permittivity (Class2)		
Test Methods and Remarks		Class 1	Class 2
	Applied voltage	Rated voltage × 3 Rated voltage (Code Q) × 2	Rated voltage × 2.5 Rated voltage (Code Q) × 2, Rated voltage (Code S) × 1.2
	Duration	1 to 5 sec.	
	Charge/discharge current	50mA max.	

5. Insulation Resistance

Specified Value	Temperature Compensating (Class1)	10000 MΩ min.
	High Permittivity (Class2) Note 1	C ≤ 0.047 μF : 10000 MΩ min. C > 0.047 μF : 500 MΩ · μF (C : Nominal capacitance)
Test Methods and Remarks	Applied voltage : Rated voltage, 500V (Code S)	
	Duration : 60 ± 5 sec.	
	Charge/discharge current : 50mA max.	

► This catalog contains the typical specification only due to the limitation of space. When you consider the purchase of our products, please check our specification. For details of each product (characteristics graph, reliability information, precautions for use, and so on), see our Web site (<http://www.ty-top.com/>).

6. Capacitance (Tolerance)

Specified Value	Temperature Compensating (Class1)	Standard	$C \leq 5\text{pF} : \pm 0.25\text{pF}$ $5\text{pF} < C \leq 10\text{pF} : \pm 0.5\text{pF}$ $C > 10\text{pF} : \pm 5\%$ (C:Nominal capacitance)		
		High Frequency Type	Refer to detailed specification		
	High Permittivity (Class2)		$\pm 10\%$ or $\pm 20\%$		
Test Methods and Remarks		Class 1		Class 2	
		Standard	High Frequency Type	$C \leq 10 \mu\text{F}$	$C > 10 \mu\text{F}$
	Preconditioning	None		Thermal treatment (at 150°C for 1hr) No.9	
	Measuring frequency	1MHz \pm 10%		1kHz \pm 10%	120 \pm 10Hz
	Measuring voltage Note 1	0.5 to 5Vrms		1 \pm 0.2Vrms	0.5 \pm 0.1rms
	Bias application	None			

7. Q or Dissipation Factor

Specified Value	Temperature Compensating (Class1)	Standard	$C < 30\text{pF} : Q \geq 400 + 20C$ $C \geq 30\text{pF} : Q \geq 1000$ (C:Nominal capacitance)		
		High Frequency Type	Refer to detailed specification		
	High Permittivity (Class2) Note 1		2.5% max.		
Test Methods and Remarks		Class 1		Class 2	
		Standard	High Frequency Type	$C \leq 10 \mu\text{F}$	$C > 10 \mu\text{F}$
	Preconditioning	None		Thermal treatment (at 150°C for 1hr) No.9	
	Measuring frequency	1MHz \pm 10%		1kHz \pm 10%	120 \pm 10Hz
	Measuring voltage Note 1	0.5 to 5Vrms		1 \pm 0.2Vrms	0.5 \pm 0.1Vrms
	Bias application	None			

8. Pre- and Post-Stress Electrical test

Measurement at 25 \pm 5°C

9. Heat treatment

Value shall be measured after test sample is heat treated at 150 +0/-10°C for an hour and kept at room temperature for 24 \pm 2hrs.
 ※ Heat treatment is applicable to High dielectric type.

10. High Temperature Exposure (Storage)

Specified Value	Temperature Compensating (Class1)	Standard	Appearance : No abnormality Cap. Change : Within $\pm 3\%$ or $\pm 0.3\text{pF}$, whichever is larger. Q : $C < 10\text{pF} : Q \geq 200 + 10C$ $10 \leq C < 30\text{pF} : Q \geq 275 + 2.5C$ $C \geq 30\text{pF} : Q \geq 350$ (C:Nominal capacitance) IR : 1000M Ω min	
		High Frequency Type	Appearance : No abnormality Cap. Change : Within $\pm 3\%$ or $\pm 0.3\text{pF}$, whichever is larger. IR : 1000M Ω min	
	High Permittivity (Class2) Note 1		Appearance : No abnormality Cap. Change : Within $\pm 12.5\%$ tan δ : 5% max IR : Within 50M Ω or 100M Ω , whichever is smaller.	
Test Methods and Remarks	Heat treatment specified in this specification shall be conducted prior to test. No.9 Temperature: The maximum operating temperature shall be used. Duration: Unpowered 1000 hrs. Measurement shall be performed after test sample following the test is heated at 150+0/-10°C for an hour and kept at room temperature for 24 \pm 2 hrs. No.9			

► This catalog contains the typical specification only due to the limitation of space. When you consider the purchase of our products, please check our specification.
 For details of each product (characteristics graph, reliability information, precautions for use, and so on), see our Web site (<http://www.ty-top.com/>).

11. Temperature Cycling			
Specified Value	Temperature Compensating (Class1)	Standard	Appearance : No abnormality Cap. Change : Within $\pm 2.5\%$ or $\pm 0.25\text{pF}$, whichever is larger. Q : Initial value IR : Initial value
		High Frequency Type	Appearance : No abnormality Cap. Change : Within $\pm 2.5\%$ or $\pm 0.25\text{pF}$, whichever is larger. IR : Initial value
	High Permittivity (Class2)		Appearance : No abnormality Cap. Change : Within $\pm 7.5\%$ $\tan \delta$: Initial value IR : Initial value
Test Methods and Remarks	Heat treatment specified in this specification shall be conducted prior to test. No.9 Temperature: Minimum operating temperature to Maximum operating temperature Number of cycles: 1000 cycles Maximum dwell time at each temperature extreme: 30 min Maximum transition time: Within 1 min Measurement shall be performed after test sample following the test is heated at $150+0/-10^\circ\text{C}$ for an hour and kept at room temperature for 24 ± 2 hours. No.9		

12. Destructive Physical Analysis	
Specified Value	No abnormality
Test Methods and Remarks	Per EIA-469

13. Biased Humidity			
Specified Value	Temperature Compensating (Class1)	Standard	Appearance : No abnormality Cap. Change : Within $\pm 7.5\%$ or $\pm 0.75\text{pF}$, whichever is larger. Q : $C < 30\text{pF} : Q \geq 100 + 10C/3$ $C \geq 30\text{pF} : Q \geq 200$ (C: Nominal capacitance) IR : $500M\Omega \text{ min}$
		High Frequency Type	Appearance : No abnormality Cap. Change : $C \leq 2.0\text{pF} : \pm 0.4\text{pF}$ $2.0\text{pF} < C < 10\text{pF} : \pm 0.75\text{pF}$ $C \geq 10\text{pF} : \pm 7.5\%$ (C: Nominal capacitance) IR : $500M\Omega \text{ min}$
	High Permittivity (Class2) Note 1		Appearance : No abnormality Cap. Change : Within $\pm 12.5\%$ $\tan \delta$: 5% max IR : Within $25M\Omega \mu\text{F}$ or $500M\Omega$ whichever is smaller.
Test Methods and Remarks	Heat treatment specified in this specification shall be conducted prior to test. No.9 Temperature: 85°C Humidity: 85%RH Duration: 1000hrs Applied voltage: Rated voltage and 1.3 to 1.5V. Measurement shall be performed after test sample following the test is heated at $150+0/-10^\circ\text{C}$ for an hour and kept at room temperature for 24 ± 2 hours. No.9		

14. Temperature Cycle (Thermal Shock)			
Specified Value	Temperature Compensating (Class1)	Standard	Appearance : No abnormality Cap. Change : Within $\pm 3.0\%$ or $\pm 0.3\text{pF}$, whichever is larger. Q : $C < 10\text{pF} : Q \geq 200 + 10C$ $10 \leq C < 30\text{pF} : Q \geq 275 + 2.5C$ $C \geq 30\text{pF} : Q \geq 350$ (C: Nominal capacitance) IR : $1000M\Omega \text{ min}$
		High Frequency Type	Appearance : No abnormality Cap. Change : Within $\pm 3.0\%$ or $\pm 0.3\text{pF}$, whichever is larger. IR : $1000M\Omega \text{ min}$
	High Permittivity (Class2) Note 1		Appearance : No abnormality Cap. Change : Within $\pm 12.5\%$ $\tan \delta$: 5% max IR : Within $50M\Omega\mu\text{F}$ or $1000M\Omega$ whichever is smaller.
Test Methods and Remarks	Heat treatment specified in this specification shall be conducted prior to test. No.9 Temperature: Maximum operating temperature Duration: 1000hrs Applied voltage: Rated voltage Measurement shall be performed after test sample following the test is heated at $150 \pm 0 / -10^\circ\text{C}$ for an hour and kept at room temperature for 24 ± 2 hours. No.9		

15. External Visual	
Specified Value	No abnormality
Test Methods and Remarks	Visual inspection shall be performed.

16. Physical Dimension	
Specified Value	Refer to detailed specification
Test Methods and Remarks	Verify physical dimensions to the applicable device specification.

17. Resistance to Solvents	
Specified Value	Appearance : No abnormality Cap. Change : Initial value Q or $\tan \delta$: Initial value IR : Initial value
Test Methods and Remarks	Heat treatment specified in this specification shall be conducted prior to test. No.9 Add Aqueous wash chemical OKEMCLEAN (A 6% concentrated Oakite cleaner) or equivalent.

18. Mechanical Shock	
Specified Value	Appearance : No abnormality Cap. Change : Initial value Q or $\tan \delta$: Initial value IR : Initial value
Test Methods and Remarks	Heat treatment specified in this specification shall be conducted prior to test. No.9 Three shocks in each direction should be applied along 3 mutually perpendicular axes of the test specimen (18 shocks). Peak value: 1500g Duration: 0.5ms Test pulse: Half-sine Velocity change: 4.7m/s.

19. Vibration	
Specified Value	Appearance : No abnormality Cap. Change : Initial value Q or $\tan \delta$: Initial value IR : Initial value
Test Methods and Remarks	Heat treatment specified in this specification shall be conducted prior to test. No.9 5g's for 20 min., 12 cycles each of 3 orientations. (Total: 36 cycles) Frequency range: 10Hz~2000Hz

20. Resistance to Soldering Heat

Specified Value	Temperature Compensating (Class1)	Standard	Appearance : No abnormality Cap. Change : Within $\pm 2.5\%$ or $\pm 0.25\text{pF}$, whichever is larger. Q : Initial value IR : Initial value
		High Frequency Type	Appearance : No abnormality Cap. Change : Within $\pm 2.5\%$ or $\pm 0.25\text{pF}$, whichever is larger. IR : Initial value
	High Permittivity (Class2) Note 1		Appearance : No abnormality Cap. Change : Within $\pm 7.5\%$ $\tan \delta$: Initial value IR : Initial value
Test Methods and Remarks	Heat treatment specified in this specification shall be conducted prior to test. No.9 Dipping Solder: $260 \pm 5^\circ\text{C}$ Time: 10 ± 1 sec. Measurement shall be performed after test sample following the test kept at room temperature for 24 ± 2 hours.		

21. ESC

Specified Value	Appearance: No abnormality IR: Initial value
Test Methods and Remarks	Heat treatment specified in this specification shall be conducted prior to test. No.9 Per AEC-Q200-002

22. Solderability

Specified Value	More than 95% of terminal electrode shall be covered with fresh solder.
Test Methods and Remarks	(a) Pb Free Solder Solder at $235 \pm 5^\circ\text{C}$ for 5sec. (b) SnPb Solder Solder at $215 \pm 5^\circ\text{C}$ for 5sec. (c) Wave Soldering (Pb Free Solder) Solder at $260 \pm 5^\circ\text{C}$ for 7sec.

23. Temperature Characteristic

Specified Value	Temperature Compensating (Class1)	Temp. chara. [ppm/ $^\circ\text{C}$]		Tolerance [ppm/ $^\circ\text{C}$]		
		$C \square : 0$	CG, CH, CJ, CK	G: ± 30 H: ± 60 J: ± 120 K: ± 250		
	High Permittivity (Class2)	Capacitance change rate		Reference temperature	Temperature range	
	B5	X5R	$\pm 15\%$	25°C	$-55 \sim +85^\circ\text{C}$	
	B7	X7R	$\pm 15\%$	25°C	$-55 \sim +125^\circ\text{C}$	
	C6	X6S	$\pm 22\%$	25°C	$-55 \sim +105^\circ\text{C}$	
	C7	X7S	$\pm 22\%$	25°C	$-55 \sim +125^\circ\text{C}$	
	D7	X7T	$+22 / -33\%$	25°C	$-55 \sim +125^\circ\text{C}$	
Test Methods and Remarks	Heat treatment specified in this specification shall be conducted prior to test. No.9 Capacitance shall be measured at room temperature as well as minimum and maximum operating temperatures.					

24. Board Flex

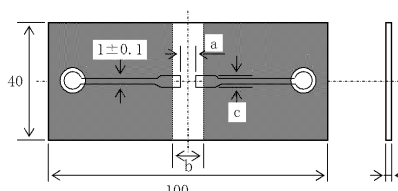
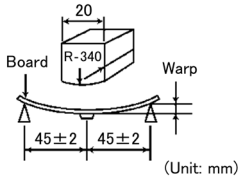
Specified Value	Appearance: No abnormality Cap. Change: $\pm 12.5\%$																																															
Test Methods and Remarks	<p>Heat treatment specified in this specification shall be conducted prior to test. No.9 Test sample is soldered onto the test board shown in Fig 1. The board is bent 2.0mm for 60 seconds as shown in Fig 2. Measurement shall be conducted as the board is bent 2.0mm.</p> <div style="display: flex; justify-content: space-around; align-items: flex-start;"> <div style="text-align: center;">  <p>Fig 1</p> </div> <table border="1" style="border-collapse: collapse; text-align: center;"> <thead> <tr> <th rowspan="2">Dimension</th> <th colspan="7">Case size [mm]</th> </tr> <tr> <th>0603</th> <th>1005</th> <th>1608</th> <th>2012</th> <th>3216</th> <th>3225</th> <th>4532</th> </tr> </thead> <tbody> <tr> <td>a</td> <td>0.3</td> <td>0.4</td> <td>1.0</td> <td>1.2</td> <td>2.2</td> <td>2.2</td> <td>3.5</td> </tr> <tr> <td>b</td> <td>0.9</td> <td>1.5</td> <td>3.0</td> <td>4.0</td> <td>5.0</td> <td>5.0</td> <td>7.0</td> </tr> <tr> <td>c</td> <td>0.3</td> <td>0.5</td> <td>1.2</td> <td>1.65</td> <td>2.0</td> <td>2.9</td> <td>3.7</td> </tr> <tr> <td>Thickness</td> <td colspan="7">0.8</td> </tr> </tbody> </table> </div> <div style="text-align: center; margin-top: 10px;">  <p>Fig 2</p> </div>	Dimension	Case size [mm]							0603	1005	1608	2012	3216	3225	4532	a	0.3	0.4	1.0	1.2	2.2	2.2	3.5	b	0.9	1.5	3.0	4.0	5.0	5.0	7.0	c	0.3	0.5	1.2	1.65	2.0	2.9	3.7	Thickness	0.8						
Dimension	Case size [mm]																																															
	0603	1005	1608	2012	3216	3225	4532																																									
a	0.3	0.4	1.0	1.2	2.2	2.2	3.5																																									
b	0.9	1.5	3.0	4.0	5.0	5.0	7.0																																									
c	0.3	0.5	1.2	1.65	2.0	2.9	3.7																																									
Thickness	0.8																																															

25. Terminal Strength

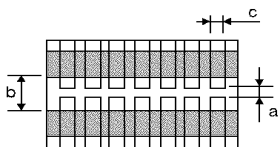
Specified Value	Appearance: No abnormality																																							
Test Methods and Remarks	<p>Per AEC-Q200-006 Test sample is soldered onto the test board shown in Fig 3. 0603 or greater (case size): 17.7N for 60\pm5 sec 0402 (case size): 5N for 30\pm5 sec. 0201 (case size): 2N for 30\pm5 sec.</p> <div style="display: flex; justify-content: space-around; align-items: flex-start;"> <div style="text-align: center;">  <p>Fig 3</p> </div> <table border="1" style="border-collapse: collapse; text-align: center;"> <thead> <tr> <th rowspan="2">Dimension</th> <th colspan="7">Case size [mm]</th> </tr> <tr> <th>0603</th> <th>1005</th> <th>1608</th> <th>2012</th> <th>3216</th> <th>3225</th> <th>4532</th> </tr> </thead> <tbody> <tr> <td>a</td> <td>0.3</td> <td>0.4</td> <td>1.0</td> <td>1.2</td> <td>2.2</td> <td>2.2</td> <td>3.5</td> </tr> <tr> <td>b</td> <td>0.9</td> <td>1.5</td> <td>3.0</td> <td>4.0</td> <td>5.0</td> <td>5.0</td> <td>7.0</td> </tr> <tr> <td>c</td> <td>0.3</td> <td>0.5</td> <td>1.2</td> <td>1.65</td> <td>2.0</td> <td>2.9</td> <td>3.7</td> </tr> </tbody> </table> </div>	Dimension	Case size [mm]							0603	1005	1608	2012	3216	3225	4532	a	0.3	0.4	1.0	1.2	2.2	2.2	3.5	b	0.9	1.5	3.0	4.0	5.0	5.0	7.0	c	0.3	0.5	1.2	1.65	2.0	2.9	3.7
Dimension	Case size [mm]																																							
	0603	1005	1608	2012	3216	3225	4532																																	
a	0.3	0.4	1.0	1.2	2.2	2.2	3.5																																	
b	0.9	1.5	3.0	4.0	5.0	5.0	7.0																																	
c	0.3	0.5	1.2	1.65	2.0	2.9	3.7																																	

26. Beam Load Test

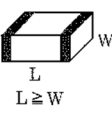
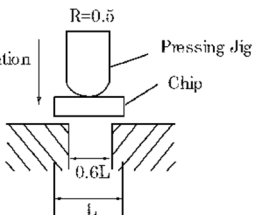
Specified Value	Destruction value should exceed 5N.
Test Methods and Remarks	<p>Per AEC-Q200-003</p> <div style="display: flex; align-items: center;"> <div style="margin-right: 20px;">  </div> <div>  </div> </div>

Note 1 The figures indicate typical specifications. Please refer to individual specifications in detail.

Multilayer Ceramic Capacitors

PRECAUTIONS

1. Circuit Design

- Precautions**
- ◆ Verification of operating environment, electrical rating and performance
 1. A malfunction of equipment in fields such as medical, aerospace, nuclear control, etc. may cause serious harm to human life or have severe social ramifications. Therefore, any capacitors to be used in such equipment may require higher safety and reliability, and shall be clearly differentiated from them used in general purpose applications.
 - ◆ Operating Voltage (Verification of Rated voltage)
 1. The operating voltage for capacitors must always be their rated voltage or less.
 - If an AC voltage is loaded on a DC voltage, the sum of the two peak voltages shall be the rated voltage or less.
 - For a circuit where an AC or a pulse voltage may be used, the sum of their peak voltages shall also be the rated voltage or less.
 2. Even if an applied voltage is the rated voltage or less reliability of capacitors may be deteriorated in case that either a high frequency AC voltage or a pulse voltage having rapid rise time is used in a circuit.

2. PCB Design

- Precautions**
- ◆ Pattern configurations (Design of Land-patterns)
 1. When capacitors are mounted on PCBs, the amount of solder used (size of fillet) can directly affect the capacitor performance. Therefore, the following items must be carefully considered in the design of land patterns:
 - (1) Excessive solder applied can cause mechanical stresses which lead to chip breaking or cracking. Therefore, please consider appropriate land-patterns for proper amount of solder.
 - (2) When more than one component are jointly soldered onto the same land, each component's soldering point shall be separated by solder-resist.
 - ◆ Pattern configurations (Capacitor layout on PCBs)

After capacitors are mounted on boards, they can be subjected to mechanical stresses in subsequent manufacturing processes (PCB cutting, board inspection, mounting of additional parts, assembly into the chassis, wave soldering of the boards, etc.). For this reason, land pattern configurations and positions of capacitors shall be carefully considered to minimize stresses.

Technical considerations

- ◆ Pattern configurations (Design of Land-patterns)

The following diagrams and tables show some examples of recommended land patterns to prevent excessive solder amounts.

(1) Recommended land dimensions for typical chip capacitors

 - Multilayer Ceramic Capacitors : Recommended land dimensions (unit: mm)

Wave-soldering

Type	1608	2012	3216	3225	
Size	L	1.6	2.0	3.2	3.2
	W	0.8	1.25	1.6	2.5
A	0.8 to 1.0	1.0 to 1.4	1.8 to 2.5	1.8 to 2.5	
B	0.5 to 0.8	0.8 to 1.5	0.8 to 1.7	0.8 to 1.7	
C	0.6 to 0.8	0.9 to 1.2	1.2 to 1.6	1.8 to 2.5	

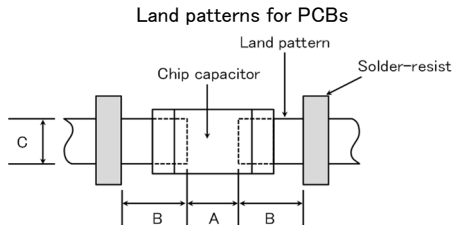

Reflow-soldering

Type	0201	0402	0603	1005	1608	2012	3216	3225	4532
Size	L	0.25	0.4	0.6	1.0	1.6	2.0	3.2	4.5
	W	0.125	0.2	0.3	0.5	0.8	1.25	1.6	3.2
A	0.095~0.135	0.15~0.25	0.20~0.30	0.45~0.55	0.6~0.8	0.8~1.2	1.8~2.5	1.8~2.5	2.5~3.5
B	0.085~0.125	0.10~0.20	0.20~0.30	0.40~0.50	0.6~0.8	0.8~1.2	1.0~1.5	1.0~1.5	1.5~1.8
C	0.110~0.150	0.15~0.30	0.25~0.40	0.45~0.55	0.6~0.8	0.9~1.6	1.2~2.0	1.8~3.2	2.3~3.5

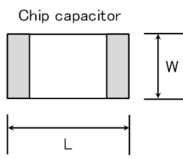

Note: Recommended land size might be different according to the allowance of the size of the product.

 - LWDC: Recommended land dimensions for reflow-soldering (unit: mm)

Type	0510	0816	1220	
Size	L	0.52	0.8	1.25
	W	1.0	1.6	2.0
A	0.18~0.22	0.25~0.3	0.5~0.7	
B	0.2~0.25	0.3~0.4	0.4~0.5	
C	0.9~1.1	1.5~1.7	1.9~2.1	

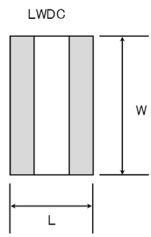

* This catalog contains the typical specification only due to the limitation of space. When you consider the purchase of our products, please check our specification. For details of each product (characteristics graph, reliability information, precautions for use, and so on), see our Web site (<http://www.ty-top.com/>).

(2) Examples of good and bad solder application

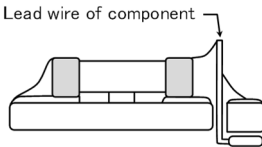
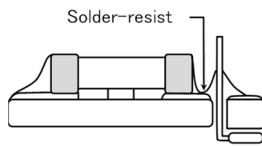
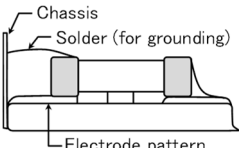
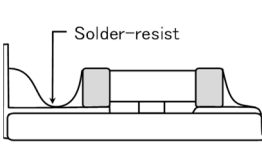
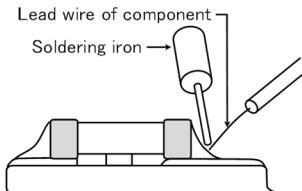
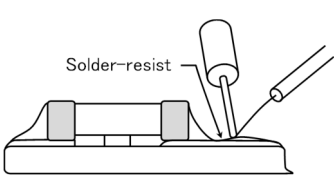
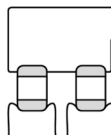
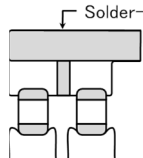
Item	Not recommended	Recommended
Mixed mounting of SMD and leaded components		
Component placement close to the chassis		
Hand-soldering of leaded components near mounted components		
Horizontal component placement		

◆ Pattern configurations (Capacitor layout on PCBs)

1-1. The following is examples of good and bad capacitor layouts ; capacitors shall be located to minimize any possible mechanical stresses from board warp or deflection.

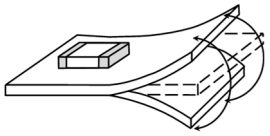
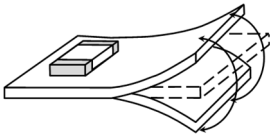
Items	Not recommended	Recommended
Deflection of board		 Place the product at a right angle to the direction of the anticipated mechanical stress.

1-2. The amount of mechanical stresses given will vary depending on capacitor layout. Please refer to diagram below.

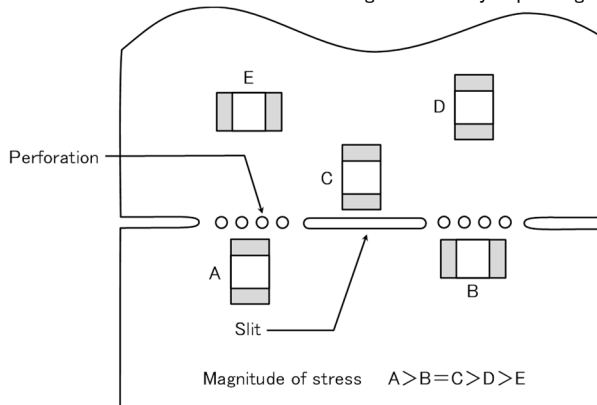

1-3. When PCB is split, the amount of mechanical stress on the capacitors can vary according to the method used. The following methods are listed in order from least stressful to most stressful: push-back, slit, V-grooving, and perforation. Thus, please consider the PCB, split methods as well as chip location.

3. Mounting

Precautions

◆ Adjustment of mounting machine

- When capacitors are mounted on PCB, excessive impact load shall not be imposed on them.
- Maintenance and inspection of mounting machines shall be conducted periodically.

◆ Selection of Adhesives

- When chips are attached on PCBs with adhesives prior to soldering, it may cause capacitor characteristics degradation unless the following factors are appropriately checked : size of land patterns, type of adhesive, amount applied, hardening temperature and hardening period. Therefore, please contact us for further information.

◆ Adjustment of mounting machine

1. When the bottom dead center of a pick-up nozzle is too low, excessive force is imposed on capacitors and causes damages. To avoid this, the following points shall be considerable.
 - (1) The bottom dead center of the pick-up nozzle shall be adjusted to the surface level of PCB without the board deflection.
 - (2) The pressure of nozzle shall be adjusted between 1 and 3 N static loads.
 - (3) To reduce the amount of deflection of the board caused by impact of the pick-up nozzle, supporting pins or back-up pins shall be used on the other side of the PCB. The following diagrams show some typical examples of good and bad pick-up nozzle placement:

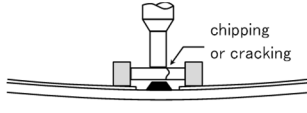
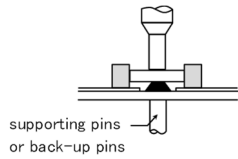
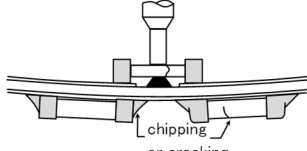
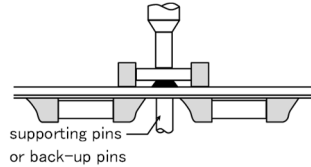
Item	Improper method	Proper method
Single-sided mounting		
Double-sided mounting		

Technical considerations

2. As the alignment pin is worn out, adjustment of the nozzle height can cause chipping or cracking of capacitors because of mechanical impact on the capacitors.
To avoid this, the monitoring of the width between the alignment pins in the stopped position, maintenance, check and replacement of the pin shall be conducted periodically.

◆ Selection of Adhesives

Some adhesives may cause IR deterioration. The different shrinkage percentage of between the adhesive and the capacitors may result in stresses on the capacitors and lead to cracking. Moreover, too little or too much adhesive applied to the board may adversely affect components. Therefore, the following precautions shall be noted in the application of adhesives.

- (1) Required adhesive characteristics
 - a. The adhesive shall be strong enough to hold parts on the board during the mounting & solder process.
 - b. The adhesive shall have sufficient strength at high temperatures.
 - c. The adhesive shall have good coating and thickness consistency.
 - d. The adhesive shall be used during its prescribed shelf life.
 - e. The adhesive shall harden rapidly.
 - f. The adhesive shall have corrosion resistance.
 - g. The adhesive shall have excellent insulation characteristics.
 - h. The adhesive shall have no emission of toxic gasses and no effect on the human body.
- (2) The recommended amount of adhesives is as follows:

[Recommended condition]

Figure	2012/3216 case sizes as examples
a	0.3mm min
b	100 to 120 μm
c	Adhesives shall not contact land

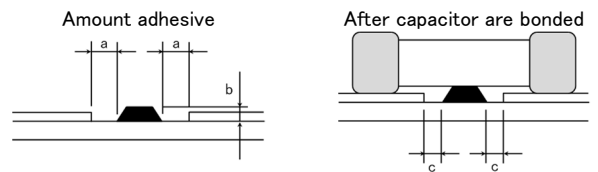

4. Soldering

◆ Selection of Flux

- Since flux may have a significant effect on the performance of capacitors, it is necessary to verify the following conditions prior to use;
- (1) Flux used shall be less than or equal to 0.1 wt% (in Cl equivalent) of halogenated content. Flux having a strong acidity content shall not be applied.
 - (2) When shall capacitors are soldered on boards, the amount of flux applied shall be controlled at the optimum level.
 - (3) When water-soluble flux is used, special care shall be taken to properly clean the boards.

Precautions

◆ Soldering

Temperature, time, amount of solder, etc. shall be set in accordance with their recommended conditions.
Sn-Zn solder paste can adversely affect MLCC reliability.
Please contact us prior to usage of Sn-Zn solder.

Technical considerations

◆ Selection of Flux

- 1-1. When too much halogenated substance (Chlorine, etc.) content is used to activate flux, or highly acidic flux is used, it may lead to corrosion of terminal electrodes or degradation of insulation resistance on the surfaces of the capacitors.
- 1-2. Flux is used to increase solderability in wave soldering. However if too much flux is applied, a large amount of flux gas may be emitted and may adversely affect the solderability. To minimize the amount of flux applied, it is recommended to use a flux-bubbling system.
- 1-3. Since the residue of water-soluble flux is easily dissolved in moisture in the air, the residues on the surfaces of capacitors in high humidity conditions may cause a degradation of insulation resistance and reliability of the capacitors. Therefore, the cleaning methods

▶ This catalog contains the typical specification only due to the limitation of space. When you consider the purchase of our products, please check our specification.
For details of each product (characteristics graph, reliability information, precautions for use, and so on), see our Web site (<http://www.ty-top.com/>).

and the capability of the machines used shall also be considered carefully when water-soluble flux is used.

◆Soldering

- Ceramic chip capacitors are susceptible to thermal shock when exposed to rapid or concentrated heating or rapid cooling.
- Therefore, the soldering must be conducted with great care so as to prevent malfunction of the components due to excessive thermal shock.
- Preheating : Capacitors shall be preheated sufficiently, and the temperature difference between the capacitors and solder shall be within 130°C.
- Cooling : The temperature difference between the capacitors and cleaning process shall not be greater than 100°C.

[Reflow soldering]

【Recommended conditions for eutectic soldering】

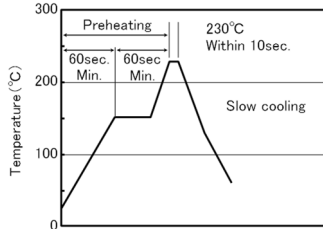

【Recommended condition for Pb-free soldering】

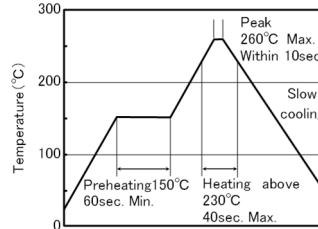

Caution

- ①The ideal condition is to have solder mass (fillet) controlled to 1/2 to 1/3 of the thickness of a capacitor.
- ②Because excessive dwell times can adversely affect solderability, soldering duration shall be kept as close to recommended times as possible. soldering for 2 times.

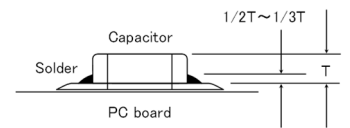

[Wave soldering]

【Recommended conditions for eutectic soldering】

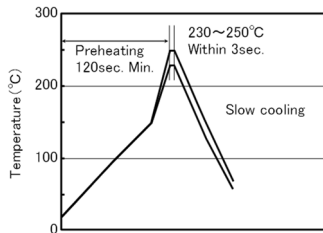

【Recommended condition for Pb-free soldering】

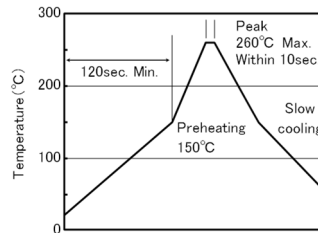

Caution

- ①Wave soldering must not be applied to capacitors designated as for reflow soldering only. soldering for 1 times.

[Hand soldering]

【Recommended conditions for eutectic soldering】

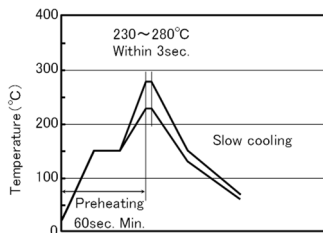

【Recommended condition for Pb-free soldering】

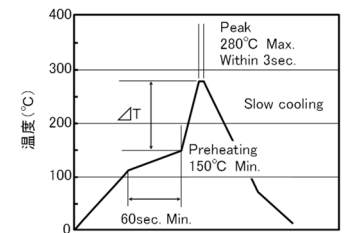
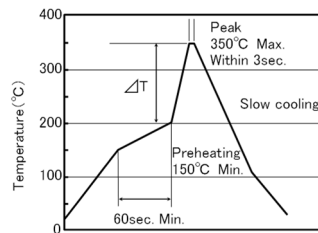

	ΔT
3216type or less	$\Delta T \leq 150^{\circ}\text{C}$

	ΔT
3225type or more	$\Delta T \leq 130^{\circ}\text{C}$

Caution

- ①Use a 50W soldering iron with a maximum tip diameter of 1.0 mm.
- ②The soldering iron shall not directly touch capacitors. soldering for 1 times.

► This catalog contains the typical specification only due to the limitation of space. When you consider the purchase of our products, please check our specification. For details of each product (characteristics graph, reliability information, precautions for use, and so on), see our Web site (<http://www.ty-top.com/>).

5. Cleaning	
Precautions	<p>◆Cleaning conditions</p> <ol style="list-style-type: none"> When PCBs are cleaned after capacitors mounting, please select the appropriate cleaning solution in accordance with the intended use of the cleaning. (e.g. to remove soldering flux or other materials from the production process.) Cleaning condition shall be determined after it is verified by using actual cleaning machine that the cleaning process does not affect capacitor's characteristics.
Technical considerations	<ol style="list-style-type: none"> The use of inappropriate cleaning solutions can cause foreign substances such as flux residue to adhere to capacitors or deteriorate their outer coating, resulting in a degradation of the capacitor's electrical properties (especially insulation resistance). Inappropriate cleaning conditions (insufficient or excessive cleaning) may adversely affect the performance of the capacitors. In the case of ultrasonic cleaning, too much power output can cause excessive vibration of PCBs which may lead to the cracking of capacitors or the soldered portion, or decrease the terminal electrodes' strength. Therefore, the following conditions shall be carefully checked: Ultrasonic output : 20 W/l or less Ultrasonic frequency : 40 kHz or less Ultrasonic washing period : 5 min. or less

6. Resin coating and mold	
Precautions	<ol style="list-style-type: none"> With some type of resins, decomposition gas or chemical reaction vapor may remain inside the resin during the hardening period or while left under normal storage conditions resulting in the deterioration of the capacitor's performance. When a resin's hardening temperature is higher than capacitor's operating temperature, the stresses generated by the excessive heat may lead to damage or destruction of capacitors. The use of such resins, molding materials etc. is not recommended.

7. Handling	
Precautions	<p>◆Splitting of PCB</p> <ol style="list-style-type: none"> When PCBs are split after components mounting, care shall be taken so as not to give any stresses of deflection or twisting to the board. Board separation shall not be done manually, but by using the appropriate devices. <p>◆Mechanical considerations</p> <p>Be careful not to subject capacitors to excessive mechanical shocks.</p> <ol style="list-style-type: none"> If ceramic capacitors are dropped onto a floor or a hard surface, they shall not be used. Please be careful that the mounted components do not come in contact with or bump against other boards or components.

8. Storage conditions	
Precautions	<p>◆Storage</p> <ol style="list-style-type: none"> To maintain the solderability of terminal electrodes and to keep packaging materials in good condition, care must be taken to control temperature and humidity in the storage area. Humidity should especially be kept as low as possible. <ul style="list-style-type: none"> Recommended conditions Ambient temperature : Below 30°C Humidity : Below 70% RH The ambient temperature must be kept below 40°C. Even under ideal storage conditions, solderability of capacitor is deteriorated as time passes, so capacitors shall be used within 6 months from the time of delivery. <ul style="list-style-type: none"> Ceramic chip capacitors shall be kept where no chlorine or sulfur exists in the air. The capacitance values of high dielectric constant capacitors will gradually decrease with the passage of time, so care shall be taken to design circuits. Even if capacitance value decreases as time passes, it will get back to the initial value by a heat treatment at 150°C for 1hour.
Technical considerations	<p>If capacitors are stored in a high temperature and humidity environment, it might rapidly cause poor solderability due to terminal oxidation and quality loss of taping/packaging materials. For this reason, capacitors shall be used within 6 months from the time of delivery. If exceeding the above period, please check solderability before using the capacitors.</p>

※RCR-2335B (Safety Application Guide for fixed ceramic capacitors for use in electronic equipment) is published by JEITA.

Please check the guide regarding precautions for deflection test, soldering by spot heat, and so on.