



General Description

The PL2702 power switches are designed for USB applications. The 32mΩ N-channel MOSFET power switch satisfies the voltage drop requirements of USB specification.

The protection features include current-limit protection, short-circuit protection, and over-temperature protection. The device limits the output current at current limit threshold level. The over-temperature protection limits the junction temperature below 140°C in case of short circuit or over load conditions. An enable input to enable or disable the device.

Features

- 32mΩ High Side MOSFET
- Voltage Range: 3.5V to 5.5V
- Current-Limit and Short-Circuit Protections
- Over-Temperature Protection
- Iset Input
- Enable Input
- Lead Free and Green Devices Available

Applications

- Notebook and Desktop Computers
- USB Ports
- High-Side Power Protection Switches

Typical Application Circuit

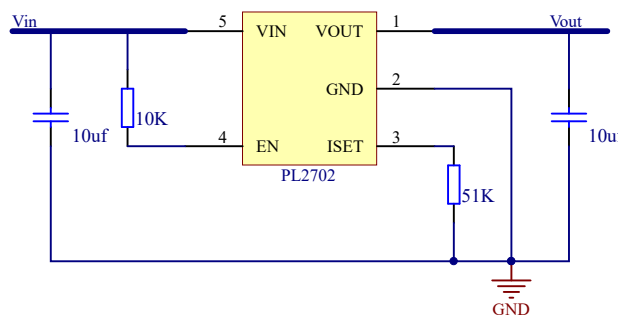



Pin Configurations

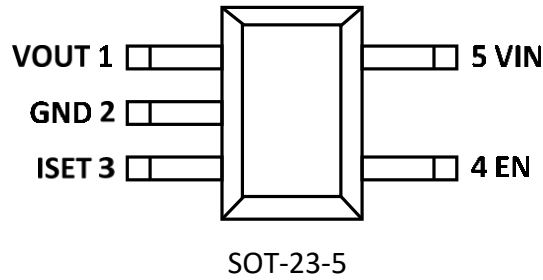

Pin Function Description

Pin Number	Pin Name	Description
1	VOUT	Output Voltage Pin. The output voltage follows the input voltage. When ENB is high or EN is low, the output voltage is discharged by an internal resistor.
2	GND	Ground.
3	ISET	i set pin. $I_{Lim}=120k*1.14V/Riset$
4	EN	Enable Input. Pulling this pin to high will enable the device and pulling this pin to low will disable device. The EN pin cannot be left floating.
5	VIN	Power Supply Input. Connect this pin to external DC supply.

Recommended Operating Conditions

Symbol	Parameter	Rating	Unit
VIN	VIN Input Voltage (VIN to GND)	3.5 to 5.5	V
IOUT	Output current	0 to 3	A
TA	Ambient Temperature	-40 to 85	°C
TJ	Junction Temperature	-40 to +125	°C
θJA	Junction-to-Ambient Resistance in Free Air	235	°C/W

Note: Refer to the typical application circuit.



Absolute Maximum Ratings

Symbol	Parameter	Rating	Unit
V _{IN}	V _{IN} Input Voltage (V _{IN} to GND)	-0.3 to 7	V
V _{OUT}	V _{OUT} to GND Voltage	-0.3 to 7	V
V _{EN}	EN to GND Voltage	-0.3 to 7	V
V _{ISET}	ISET to GND Voltage	-0.3 to 7	V
T _J	Maximum Junction Temperature	150	°C
T _{STG}	Storage Temperature Range	-65 to +150	°C
T _{SDR}	Maximum Soldering Temperature Range, 10 seconds	260	°C

Note 1: Absolute Maximum Ratings are those values beyond which the life of a device may be impaired. Exposure to absolute maximum rating conditions for extended periods may affect device reliability.

Functional Block Diagram

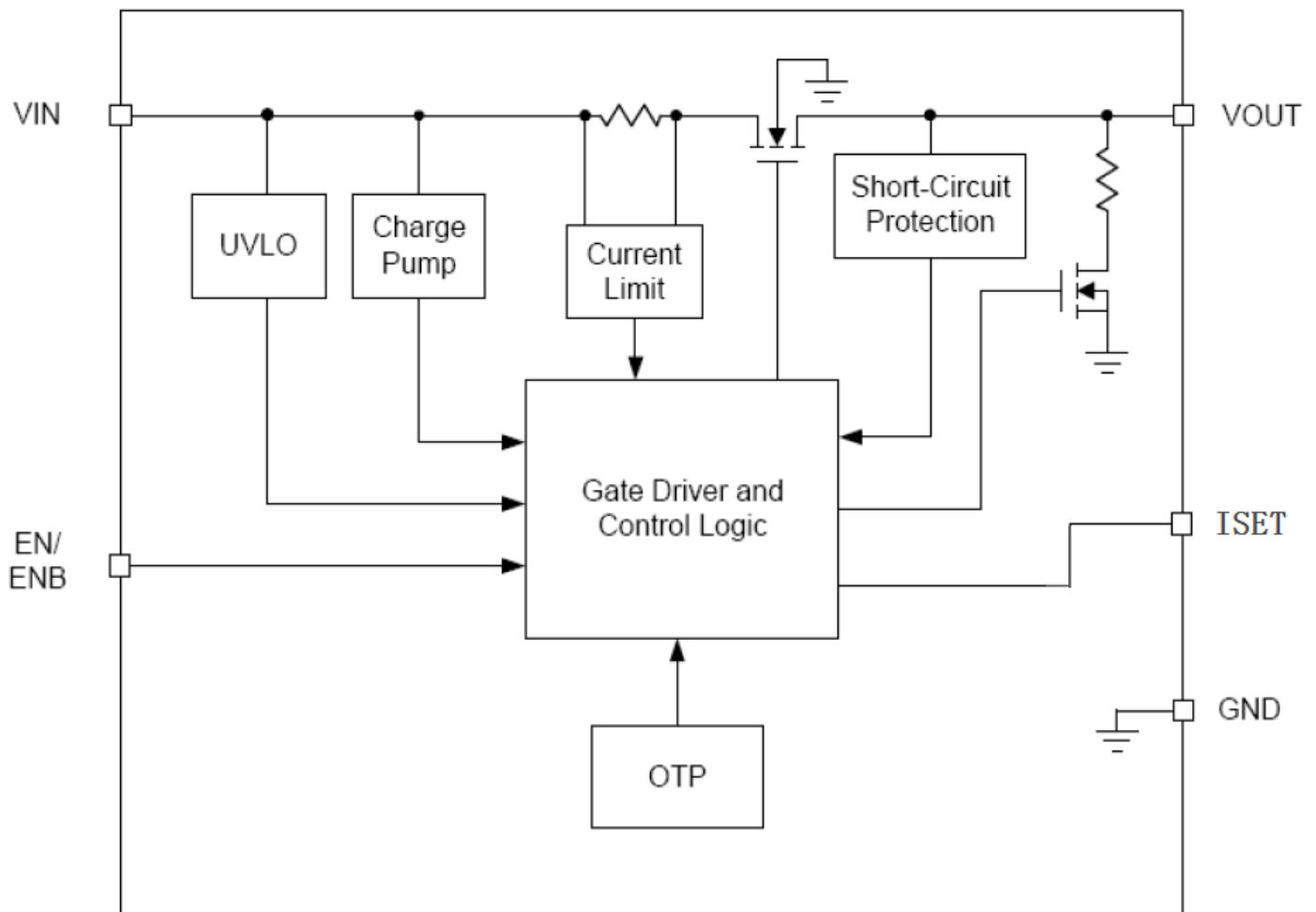



Electrical Characteristics

Unless otherwise specified, these specifications apply over $V_{IN}=5V$, $V_{EN}=5V$ and $T_A=-40 \sim 85 \text{ }^\circ\text{C}$. Typical values are at $T_A=25 \text{ }^\circ\text{C}$

Symbol	Parameter	Test Conditions	Min.	Typ.	Max.	Unit
SUPPLY CURRENT						
	VIN Supply Current	No load, $V_{EN}=0V$	-	-	1	μA
		No load, $V_{EN}=5V$	-	120	150	μA
	Leakage Current	$V_{OUT}=\text{GND}$, $V_{EN}=0V$	-	-	1	μA
	Reverse Leakage Current	$V_{IN}=\text{GND}$, $V_{OUT}=5V$, $V_{EN}=0V$	-	-	1	μA
POWER SWITCH						
RDS(ON)	Power Switch On Resistance	$I_{OUT}=1A$, $T_A=25 \text{ }^\circ\text{C}$	-	32	36	$\text{m}\Omega$
UNDER-VOLTAGE LOCKOUT (UVLO)						
	VIN UVLO Threshold Voltage	V_{IN} rising, $T_A=-40 \sim 85 \text{ }^\circ\text{C}$	-	3.5	-	V
	VIN UVLO Hysteresis		-	0.2	-	V
CURRENT-LIMIT AND SHORT-CIRCUIT PROTECTIONS						
ILIM	Current Limit Threshold	iset	1.1	-	3.9	A
		Iset(Riset=51k)	2.4	2.6	2.9	A
ISHORT	Short-Circuit Output Current		80%	-	95%	-
EN INPUT PIN						
VIH	Input Logic High	$V_{IN}=3.6V$ to $5V$	2	-	-	V
VL	Input Logic Low	$V_{IN}=3.6V$ to $5V$	-	-	0.8	V
	Input Current		-	-	1	μA
	V_{OUT} Discharge Resistance	$V_{EN}=0V$, $V_{OUT}=1V$	-	40	-	Ω
tD(ON)	Turn On Delay Time		-	30	-	μS
tD(OFF)	Turn Off Delay Time		-	30	-	μS
tSS	Soft-Start Time	No load, $C_{OUT}=1\mu\text{F}$, $V_{IN}=5V$	-	400	-	μS
OVER-TEMPERATURE PROTECTION (OTP)						
TOTP	Over-Temperature Threshold	T_J rising	-	140	-	$^\circ\text{C}$
	Over-Temperature Hysteresis		-	20	-	$^\circ\text{C}$



Typical Operating Characteristics

RDS(ON) VS Input Voltage

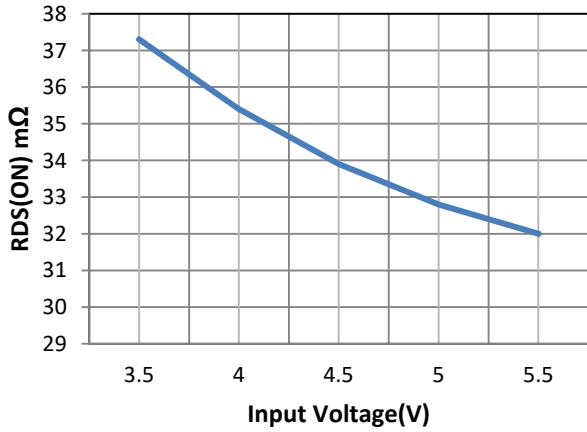

Supply Current VS Input Voltage

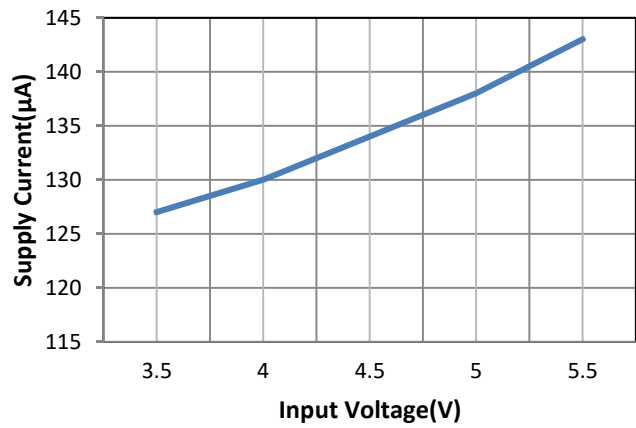

I_{LIM} VS RSET

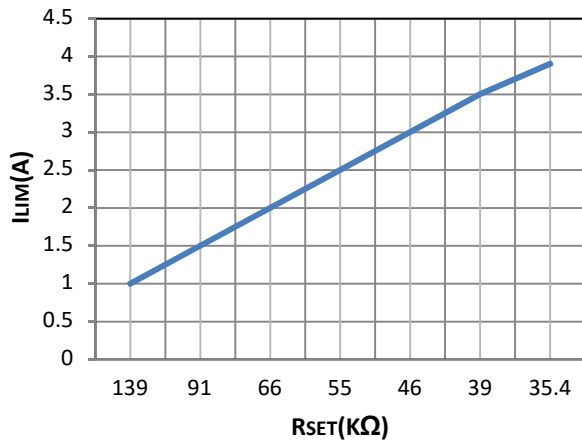

RDS(ON) VS Temperature

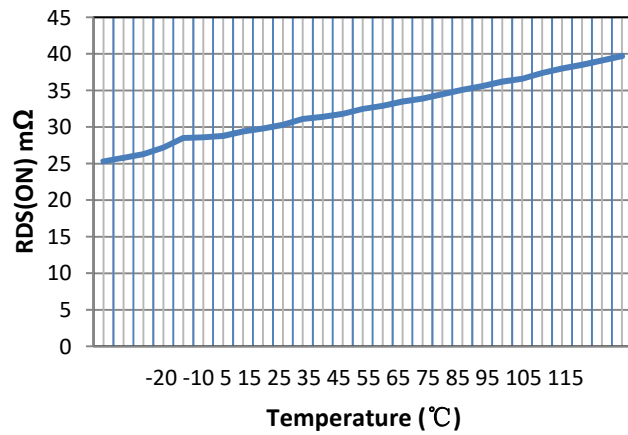



Typical Operating Characteristics(Cont.)

EN OFF

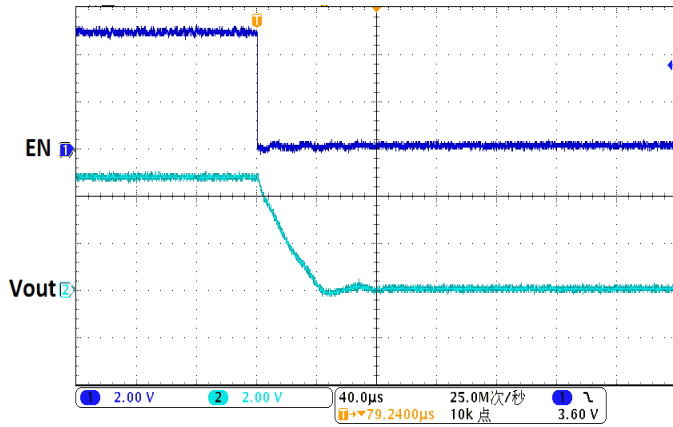

EN ON

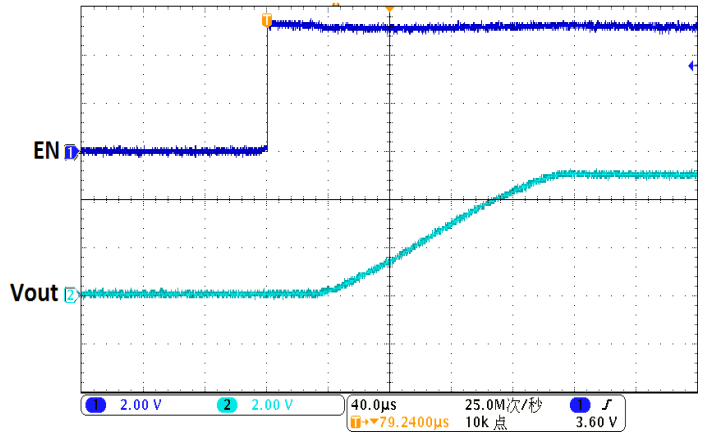

Short current

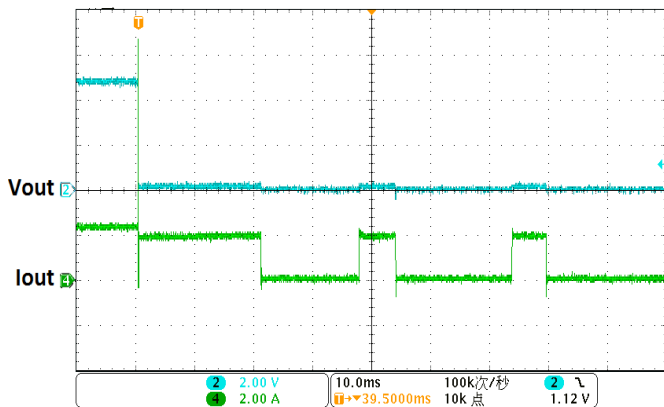



Function Description

VIN Under-Voltage Lockout (UVLO)

The PL2702 power switches have a built-in under-voltage lockout circuit to keep the output shutting off until internal circuitry is operating properly. The UVLO circuit has hysteresis and a de-glitch feature so that it will typically ignore undershoot transients on the input. When input voltage exceeds the UVLO threshold, the output voltage starts a soft-start to reduce the inrush current.

Power Switch

The power switch is an N-channel MOSFET with a low RDS(ON). The internal power MOSFET does not have the body diode. When IC is off, the MOSFET prevents a current flowing from the VOUT back to VIN and VIN to VOUT.

Current-Limit Protection

The PL2702 power switches provide the current-limit protection function. During current-limit, the devices limit output current at current limit threshold. For reliable operation, the device should not be operated in current-limit for extended period.

Short-Circuit Protection

When the output voltage drops below 1.5V, which is caused by an over-load or a short-circuit, the devices limit the output current down to a safe level. The short-circuit current limit is used to reduce the power dissipation during short-circuit conditions. If the junction temperature reaches over-temperature threshold, the device will enter the thermal shutdown.

ISET

ISET pin can set the current limit by Riset: $I_{Lim}=120k*1.14V/Riset$

Enable/Disable

Pull the EN below 0.8V will disable the device, and pull EN above 2V will enable the device. When the IC is disabled, the supply current is reduced to less than 1 μ A. The enable input is compatible with both TTL and CMOS logic levels. The EN pin cannot be left floating.



Over-Temperature Protection

When the junction temperature exceeds 140°C, the internal thermal sense circuit turns off the power FET and allows the device to cool down. When the device's junction temperature cools by 20°C, the internal thermal sense circuit will enable the device, resulting in a pulsed output during continuous thermal protection. Thermal protection is designed to protect the IC in the event of over temperature conditions. For normal operation, the junction temperature cannot exceed $T_J=+125^{\circ}\text{C}$.

Application Information

Input Capacitor

A 1μF ceramic bypass capacitor from VIN to GND, located near the PL2702, is strongly recommended to suppress the ringing during short circuit fault event. Without the bypass capacitor, the output short may cause sufficient ringing on the input (from supply lead inductance) to damage internal control circuitry.

Output Capacitor

A low-ESR 10μF aluminum electrolytic or tantalum between V_{OUT} and GND is strongly recommended to reduce the voltage drop during hot-attachment of downstream peripheral. (Per USB 2.0, output ports must have a minimum 120μF of low-ESR bulk capacitance per hub).

Higher-value output capacitor is better when the output load is heavy. Additionally, bypassing the output with a 0.1μF ceramic capacitor improves the immunity of the device to short-circuit transients.



Layout Consideration

The PCB layout should be carefully performed to maximize thermal dissipation and to minimize voltage drop, droop and EMI. The following guidelines must be considered:

1. Please place the input capacitors near the VIN pin as close as possible.
2. Output decoupling capacitors for load must be placed near the load as close as possible for decoupling high frequency ripples.
3. Locate PL2702 and output capacitors near the load to reduce parasitic resistance and inductance for excellent load transient performance.
4. The negative pins of the input and output capacitors and the GND pin must be connected to the ground plane of the load.
5. Keep V_{IN} and V_{OUT} traces as wide and short as possible.



Package Information

SOT-23-5

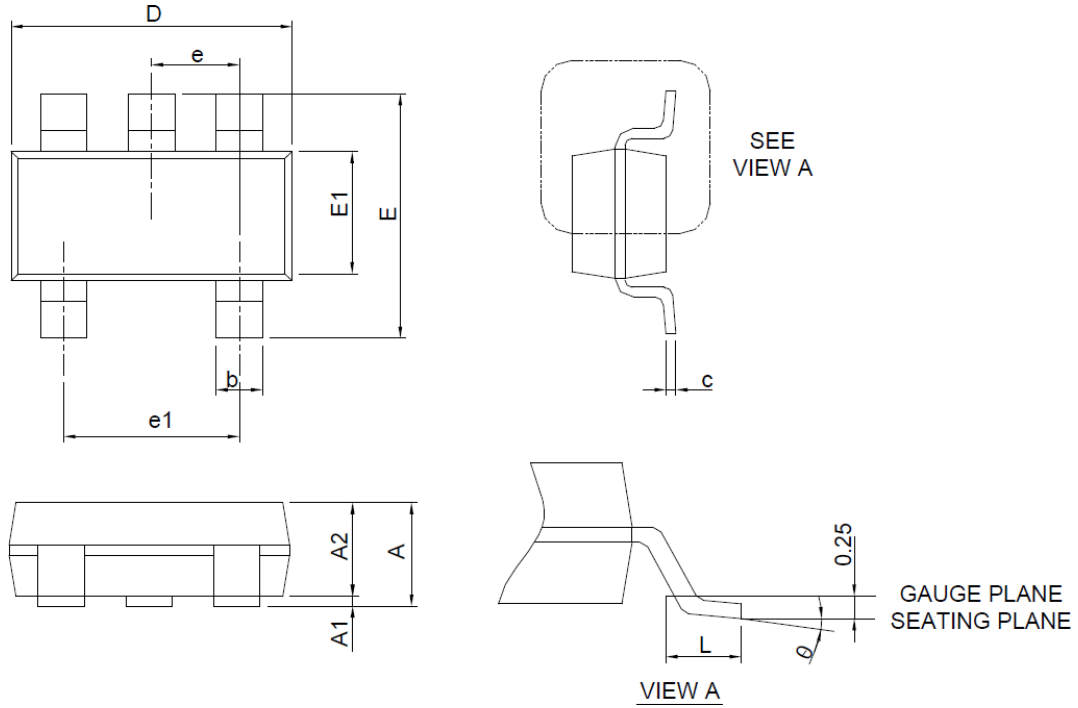

Symbol	SOT-23-5			
	MILLMETER		INCHES	
	MIN.	MAX.	MIN.	MAX.
A		1.45		0.057
A1	0.00	0.15	0.000	0.006
A2	0.90	1.30	0.035	0.051
b	0.30	0.50	0.012	0.020
c	0.08	0.22	0.003	0.009
D	2.70	3.10	0.106	0.122
E	2.60	3.00	0.102	0.118
E1	1.40	1.80	0.055	0.071
e	0.95BSC		0.037BSC	
e1	1.90BSC		0.075BSC	
L	0.30	0.60	0.012	0.024
θ	0°	8°	0°	8°