

Description

SMBJ Series transient voltage suppressors are excellent overvoltage protective devices.

The Series is designed specifically to protect sensitive electronic equipment from voltage transients induced by lightning and other transient voltage events.



SMB (DO-214AA)

Features

- Excellent clamping capability
- Low leakage current
- High surge capability
- Glass passivated chip
- Epoxy resin package
- Built-in strain relief
- Will not fatigue
- RoHS Compliant
- Fast response time: typically less than 1.0ps from 0 Volts to VBR min

Mechanical Characteristics

- Package: SMB plastic package.
- Lead Finish: Matte Tin
- Case Material: Epoxy Molding Compound.
- UL Flammability Classification Rating 94V-0
- Moisture Sensitivity: Level 1 per J-STD-020

Applications

- Telecom
- Computer
- Industrial electronic
- Consumer electronic

Electrical Parameters

Parameter	Definition
C_J	Junction Capacitance - typical capacitance measured with 0V or V_R bias
I_{PP}	Peak Pulse Current - maximum rated peak impulse current
V_C	Clamping Voltage - Peak voltage measured across the suppressor at a specified I_{ppm} (peak impulse current)
V_{BR}	Breakdown Voltage - Maximum voltage that flows through the TVS at a specified test current (I_T)
I_R	Leakage Current - maximum peak off-state current measured at V_R
V_R	Peak Off-state Voltage - maximum voltage that can be applied while maintaining off state

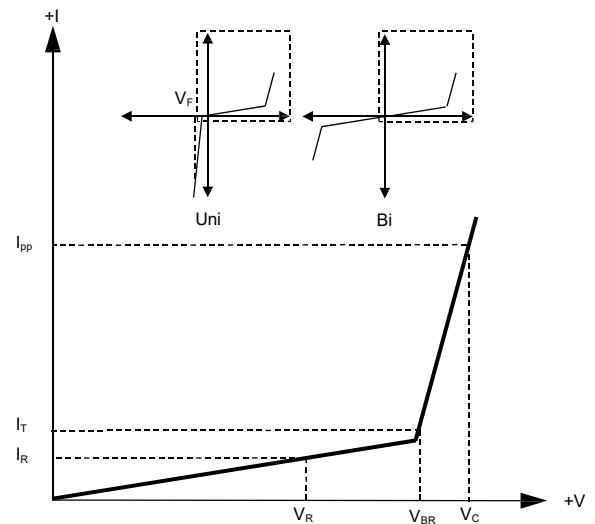

Absolute Maximum Ratings (TA=25°C unless otherwise noted)

Parameter	Symbol	Value	Units	Remarks
Peak Pulse Power Dissipation	P _{PPM}	600	W	(Note1)(Note2)
Steady State Power Dissipation	P _D	5	W	(Note3)
Peak Forward Surge Current	I _{FSM}	100	A	(Note4)
Maximum Instantaneous Forward Voltage at 50A	V _{FM}	3.5/5	V	(Note5)
Typical Thermal Resistance Junction to Lead	R _{θJL}	20	°C/W	
Typical Thermal Resistance Junction to Ambient	R _{θJA}	100	°C/W	
Operating Temperature Range	T _J	-55 to 150	°C	
Storage Temperature Range	T _{STG}	-55 to 150	°C	

Notes1: Non-repetitive current pulse , 10/1000us Waveform.

Notes2: Mounted on copper pad area of 5×5mm to each terminal.

Notes3: Infinite HeatSink at T_L=50°C

Notes4: Measured on 8.3ms single half sine wave or equivalent square wave, duty cycle=4 perminute maximum.

Notes5: For UnidirectionalOnly, V_{FM}<3.5V for V_{BR} ≤200V and V_{FM}<5.0V for V_{BR}≥201V.

Electrical Characteristics (TA=25°C unless otherwise)

Part Number (Uni)	Part Number (Bi)	Marking Code		Reverse Stand off Voltage V _R (V)	Breakdown Voltage V _{BR} @ I _T (V)		Test Current I _T (mA)	Maximum Clamping Voltage V _C @ I _{PP} (V)	Maximum Peak Pulse Current I _{PP} (A)	Maximum Reverse Leakage I _R @ V _R (μA)
		Uni	Bi		Min	Max				
SMBJ5.0A	SMBJ5.0CA	KE	AE	5	6.4	7	10	9.2	65.3	800
SMBJ6.0A	SMBJ6.0CA	KG	AG	6	6.67	7.37	10	10.3	58.3	800
SMBJ6.5A	SMBJ6.5CA	KK	AK	6.5	7.22	7.98	10	11.2	53.6	500
SMBJ7.0A	SMBJ7.0CA	KM	AM	7	7.78	8.6	10	12	50	200
SMBJ7.5A	SMBJ7.5CA	KP	AP	7.5	8.33	9.21	1	12.9	46.6	100
SMBJ8.0A	SMBJ8.0CA	KR	AR	8	8.89	9.83	1	13.6	44.2	50
SMBJ8.5A	SMBJ8.5CA	KT	AT	8.5	9.44	10.4	1	14.4	41.7	20
SMBJ9.0A	SMBJ9.0CA	KV	AV	9	10	11.1	1	15.4	39	10
SMBJ10A	SMBJ10CA	KX	AX	10	11.1	12.3	1	17	35.3	5
SMBJ11A	SMBJ11CA	KZ	AZ	11	12.2	13.5	1	18.2	33	1
SMBJ12A	SMBJ12CA	LE	BE	12	13.3	14.7	1	19.9	30.2	1
SMBJ13A	SMBJ13CA	LG	BG	13	14.4	15.9	1	21.5	28	1
SMBJ14A	SMBJ14CA	LK	BK	14	15.6	17.2	1	23.2	25.9	1
SMBJ15A	SMBJ15CA	LM	BM	15	16.7	18.5	1	24.4	24.6	1
SMBJ16A	SMBJ16CA	LP	BP	16	17.8	19.7	1	26	23.1	1
SMBJ17A	SMBJ17CA	LR	BR	17	18.9	20.9	1	27.6	21.8	1
SMBJ18A	SMBJ18CA	LT	BT	18	20	22.1	1	29.2	20.6	1
SMBJ20A	SMBJ20CA	LV	BV	20	22.2	24.5	1	32.4	18.6	1

Electrical Characteristics (TA=25°C unless otherwise noted)

Part Number (Uni)	Part Number (Bi)	Marking Code		Reverse Stand off Voltage V _R (V)	Breakdown Voltage V _{BR} @ I _T (V)		Test Current I _T (mA)	Maximum Clamping Voltage V _C @ I _{PP} (V)	Maximum Peak Pulse Current I _{PP} (A)	Maximun Reverse Leakage I _R @ V _R (μA)
		Uni	Bi		Min	Max				
SMBJ22A	SMBJ22CA	LX	BX	22	24.4	26.9	1	35.5	16.9	1
SMBJ24A	SMBJ24CA	LZ	BZ	24	26.7	29.5	1	38.9	15.5	1
SMBJ26A	SMBJ26CA	ME	CE	26	28.9	31.9	1	42.1	14.3	1
SMBJ28A	SMBJ28CA	MG	CG	28	31.1	34.4	1	45.4	13.3	1
SMBJ30A	SMBJ30CA	MK	CK	30	33.3	36.8	1	48.4	12.4	1
SMBJ33A	SMBJ33CA	MM	CM	33	36.7	40.6	1	53.3	11.3	1
SMBJ36A	SMBJ36CA	MP	CP	36	40	44.2	1	58.1	10.4	1
SMBJ40A	SMBJ40CA	MR	CR	40	44.4	49.1	1	64.5	9.3	1
SMBJ43A	SMBJ43CA	MT	CT	43	47.8	52.8	1	69.4	8.7	1
SMBJ45A	SMBJ45CA	MV	CV	45	50	55.3	1	72.7	8.3	1
SMBJ48A	SMBJ48CA	MX	CX	48	53.3	58.9	1	77.4	7.8	1
SMBJ51A	SMBJ51CA	MZ	CZ	51	56.7	62.7	1	82.4	7.3	1
SMBJ54A	SMBJ54CA	NE	DE	54	60	66.3	1	87.1	6.9	1
SMBJ58A	SMBJ58CA	NG	DG	58	64.4	71.2	1	93.6	6.5	1
SMBJ60A	SMBJ60CA	NK	DK	60	66.7	73.7	1	96.8	6.2	1
SMBJ64A	SMBJ64CA	NM	DM	64	71.1	78.6	1	103	5.9	1
SMBJ70A	SMBJ70CA	NP	DP	70	77.8	86	1	113	5.3	1
SMBJ75A	SMBJ75CA	NR	DR	75	83.3	92.1	1	121	5	1
SMBJ78A	SMBJ78CA	NT	DT	78	86.7	95.8	1	126	4.8	1
SMBJ85A	SMBJ85CA	NV	DV	85	94.4	104	1	137	4.4	1
SMBJ90A	SMBJ90CA	NX	DX	90	100	111	1	146	4.1	1
SMBJ100A	SMBJ100CA	NZ	DZ	100	111	123	1	162	3.7	1
SMBJ110A	SMBJ110CA	PE	EE	110	122	135	1	177	3.4	1
SMBJ120A	SMBJ120CA	PG	EG	120	133	147	1	193	3.1	1
SMBJ130A	SMBJ130CA	PK	EK	130	144	159	1	209	2.9	1
SMBJ150A	SMBJ150CA	PM	EM	150	167	185	1	243	2.5	1
SMBJ160A	SMBJ160CA	PP	EP	160	178	197	1	259	2.3	1
SMBJ170A	SMBJ170CA	PR	ER	170	189	209	1	275	2.2	1
SMBJ180A	SMBJ180CA	PT	ET	180	201	222	1	292	2.1	1
SMBJ200A	SMBJ200CA	PV	EV	200	224	247	1	324	1.9	1
SMBJ220A	SMBJ220CA	PX	EX	220	246	272	1	356	1.7	1
SMBJ250A	SMBJ250CA	PZ	EZ	250	279	309	1	405	1.5	1
SMBJ300A	SMBJ300CA	QE	FE	300	335	371	1	486	1.3	1
SMBJ350A	SMBJ350CA	QG	FG	350	391	432	1	567	1.1	1
SMBJ400A	SMBJ400CA	QK	FK	400	447	494	1	648	0.9	1
SMBJ440A	SMBJ440CA	QM	FM	440	492	543	1	713	0.9	1

Rating And Characteristic Curves (TA=25°C unless otherwise noted)

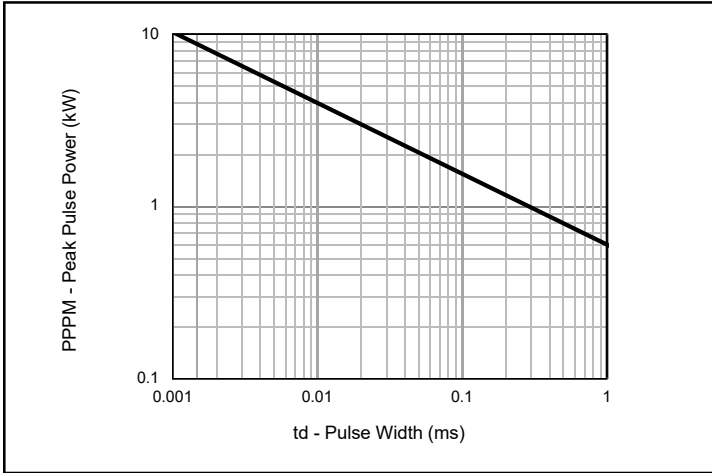

Fig. 1 - Peak Pulse Power Rating

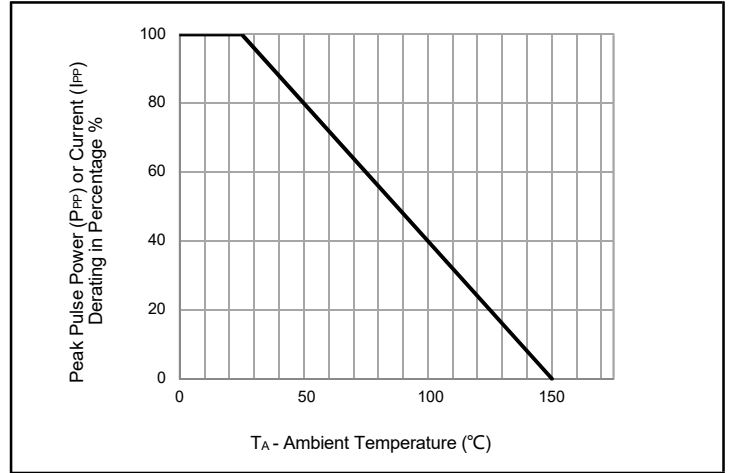

Fig. 2 - Pulse Derating Curve

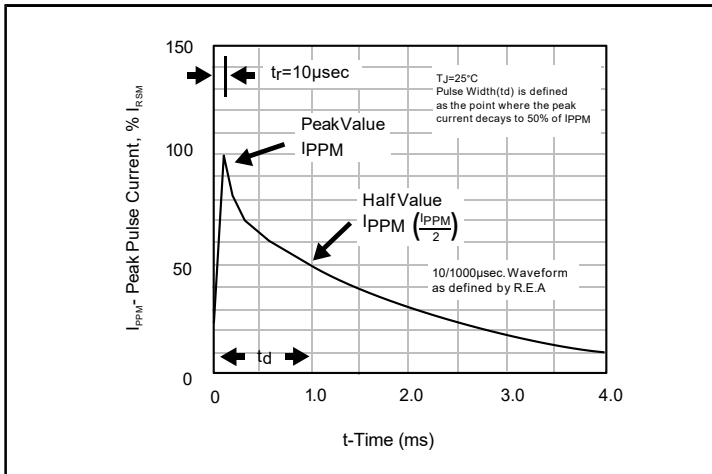

Fig. 3 - Pulse Waveform

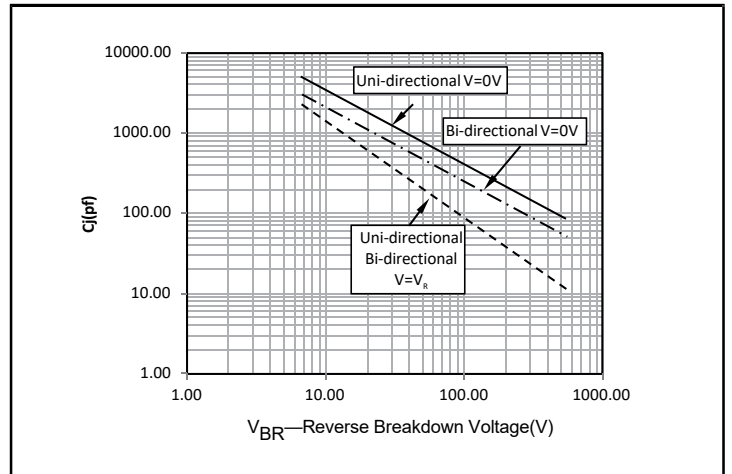

Fig. 4 - Typical Junction Capacitance

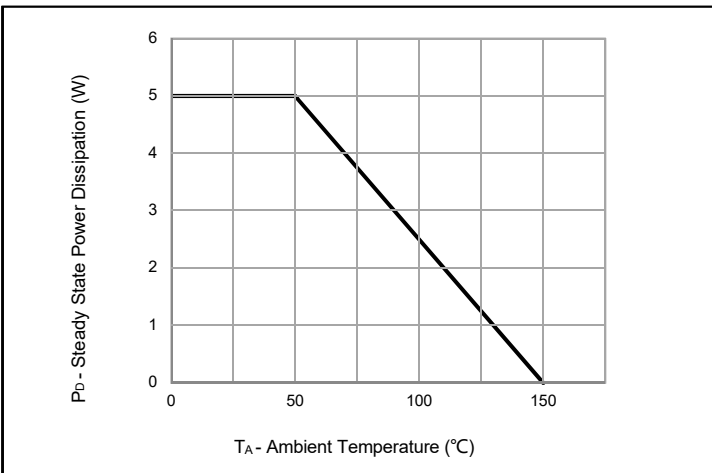

Fig. 5 - Steady State Power Dissipation Derating Curve

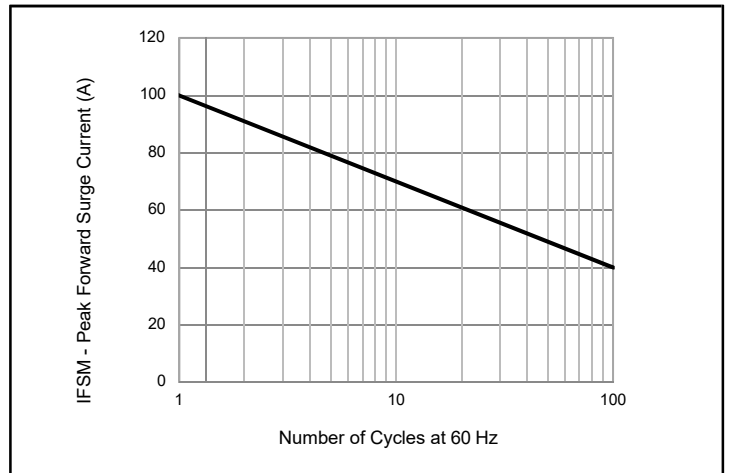
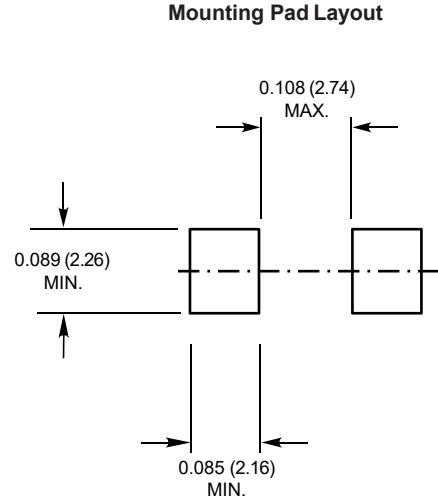
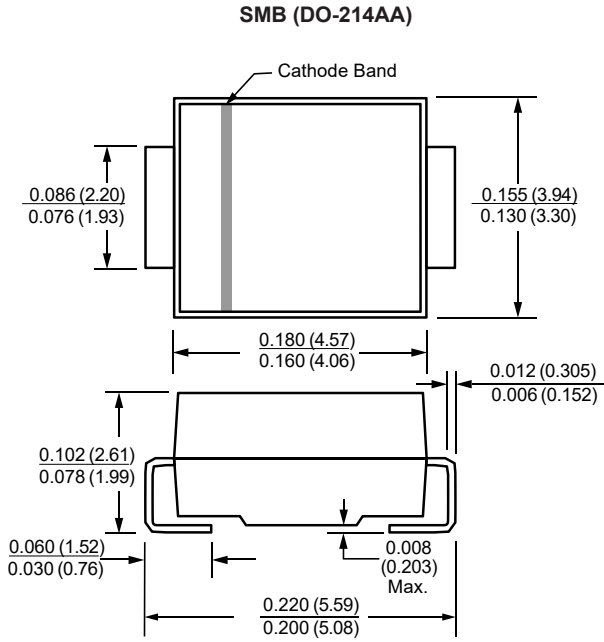
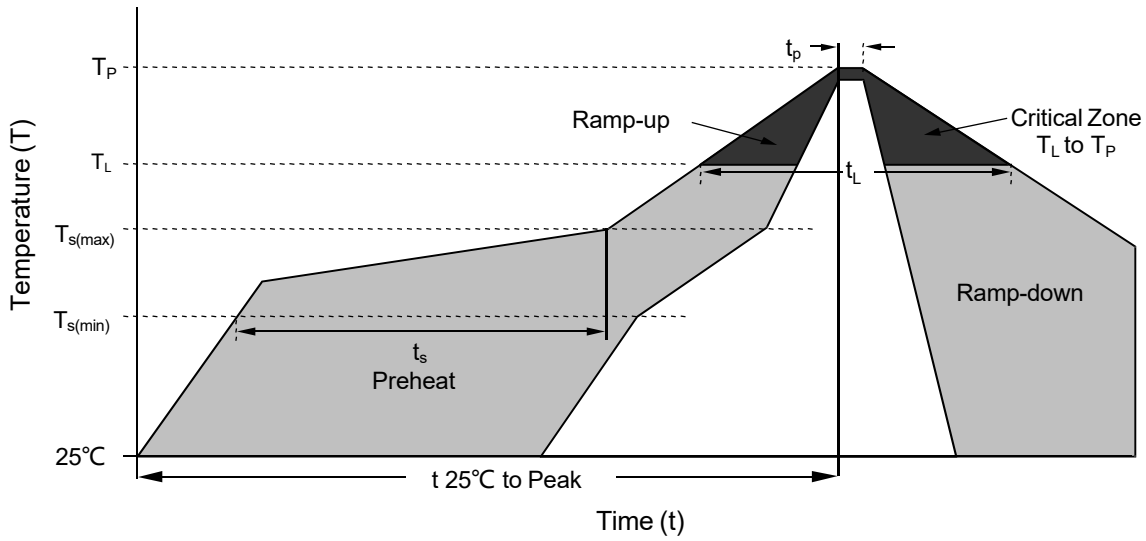

Fig. 6 - Maximum Non-Repetitive Peak Forward Surge Current Uni-Directional Only

Package Outline Dimensions in inches (millimeters)



Soldering Parameters



Reflow Condition		Lead-free assembly
Pre Heat	- Temperature Min ($T_{s(min)}$)	150°C
	- Temperature Max ($T_{s(max)}$)	200°C
	- Time (min to max) (t_s)	60 – 180 secs
Average ramp up rate (Liquidus Temp (T_L) to peak)		3°C/second max
$T_{s(max)}$ to T_L - Ramp-up Rate		3°C/second max
Reflow	- Temperature (T_L) (Liquidus)	217°C
	- Time (t_L)	60 – 150 secs
Peak Temperature (T_P)		260 ^{+0/-5} °C
Time within 5°C of actual peak Temperature (t_p)		20 – 40 secs
Ramp-down Rate		6°C/second max
Time 25°C to peak Temperature (t)		8 minutes Max.
Do not exceed		260°C

Part Numbering System

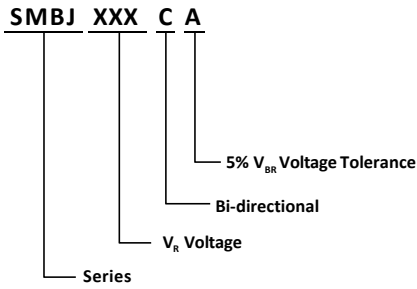

Part Marking System

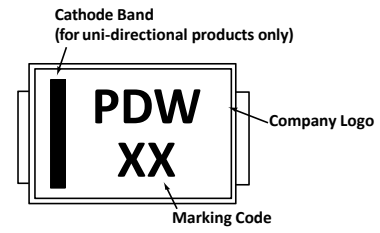

Summary of Packing Options

Package	Packing Description	Packing Quantity
SMB	Tape/Reel, 13" reel	3000

Tape and Reel Specification

