

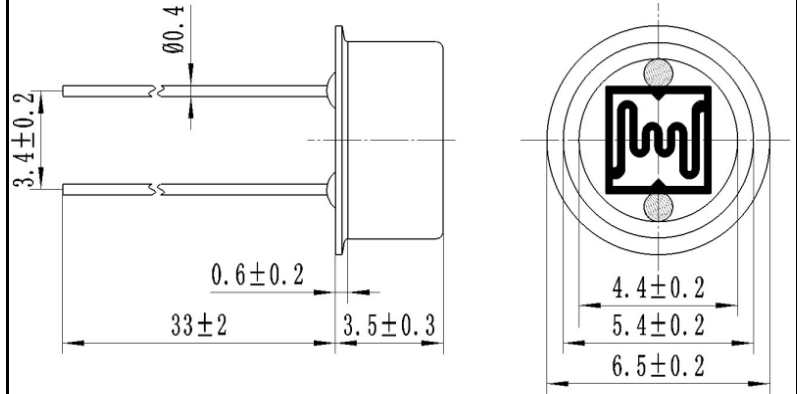

**FEATURES**

- Miniature open frame package
- Epoxy coated
- Moisture resistant
- Spectral response similar to the human eye
- Applications include dusk-dawn lighting control

**LIGHT DEPENDENT RESISTOR**



Dimensions in millimetres

**SPECIFICATION AND PERFORMANCE**

Model	Vmax (VDC)	Pmax (mW)	Ambient temp(°C)	Spectral peak (nm)	Light Resistance at 10Lux (KΩ)	Dark Resistance (MΩ)	Gamma a value at 100-10Lux	Response Time (ms)	
								Rise Time	Decay time
GL5501F	100	100	-30~+70	540	5-10	1	0.75	30	30

**Measuring Conditions**

- 1. Light resistance:**  
Measured at 10 Lux with standard light A (2854K color temperature) and 2hr illumination at 400-600 lux prior to testing.
- 2. Dark Resistance:**  
Measured 10 seconds after closed 10 lux.
- 3. Gamma Characteristic:**  
Between 10 lux and 100 lux and given by  $\gamma = \lg(R_{10}/R_{100})$   
R10、R100 Cell resistance at 10 lux and 100 lux.  
The error of  $\gamma$  is  $\pm 0.1$ .
- 4. Pmax:**  
Max. power dissipation at ambient temperature of 25 °C.
- 5. Vmax:**  
Max. voltage in darkness that may be applied to the cell continuously.

**Spectral Response**

