

**Features**

- The plastic package carries UL Flammability Classification 94V-0
- For surface mounted applications
- Low reverse leakage
- Built-in strain relief, ideal for automated placement
- High forward surge current capability
- High temperature soldering guaranteed:260°C/10 seconds at terminals



SMB (DO-214AA)

**Mechanical Characteristics**

- Case: SMB(DO-214AA) package molded plastic body over passivated chip
- Terminals: Solder plated, solderable per MIL-STD-750, Method 2026
- Polarity: Color band denotes cathode end
- Mounting Position: Any

**Absolute Maximum Ratings and Electrical Parameters (TA=25°C unless otherwise specified)**

PARAMETER	SYMBOL	S5AB	S5BB	S5DB	S5GB	S5JB	S5KB	S5MB	UNIT	
Maximum repetitive peak reverse voltage	$V_{RRM}$	50	100	200	400	600	800	1000	V	
Maximum RMS voltage	$V_{RMS}$	35	70	140	280	420	560	700	V	
Maximum DC blocking voltage	$V_{DC}$	50	100	200	400	600	800	1000	V	
Maximum average forward rectified current	$I_{AV}$	5							A	
Peak forward surge current <sup>(NOTE1)</sup>	$I_{FSM}$	150							A	
Maximum instantaneous forward voltage at 5A	$V_F$	1.1							V	
Maximum DC reverse current at rated DC blocking voltage	$T_A=25\text{ }^\circ\text{C}$	$I_R$	5							$\mu\text{A}$
	$T_A=100\text{ }^\circ\text{C}$	$I_{RT}$	50							$\mu\text{A}$
Typical junction capacitance <sup>(NOTE 2)</sup>	$C_J$	75							pF	
Typical Thermal Resistance Junction to Ambient <sup>(NOTE3)</sup>	$R_{\theta JA}$	65							$^\circ\text{C/W}$	
Typical Thermal Resistance Junction to Lead <sup>(NOTE3)</sup>	$R_{\theta JL}$	20							$^\circ\text{C/W}$	
Operating Temperature Range	$T_J$	-55 to 150							$^\circ\text{C}$	
Storage Temperature Range	$T_{STG}$	-55 to 150							$^\circ\text{C}$	

Note1: 8.3ms single half sine-wave superimposed on rated load

Note2: Measured at 1MHz and applied reverse voltage of 4.0V DC.

Note3: PCB. mounted with 7x7mm copper pad areas

**Rating And Characteristic Curves (TA=25°C unless otherwise noted)**

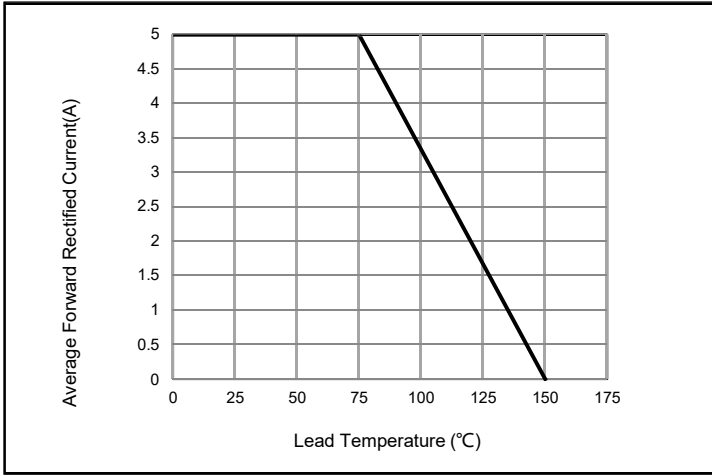

Fig. 1 - Forward Current Derating Curve

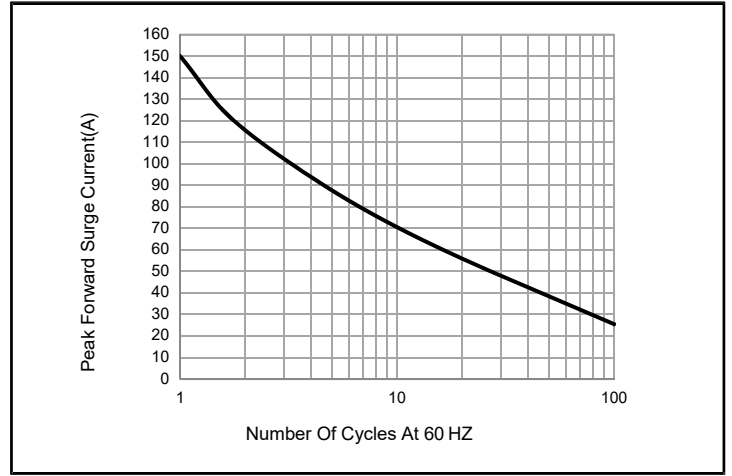

Fig. 2 - Maximum Non-Repetitive Peak Forward Surge Current

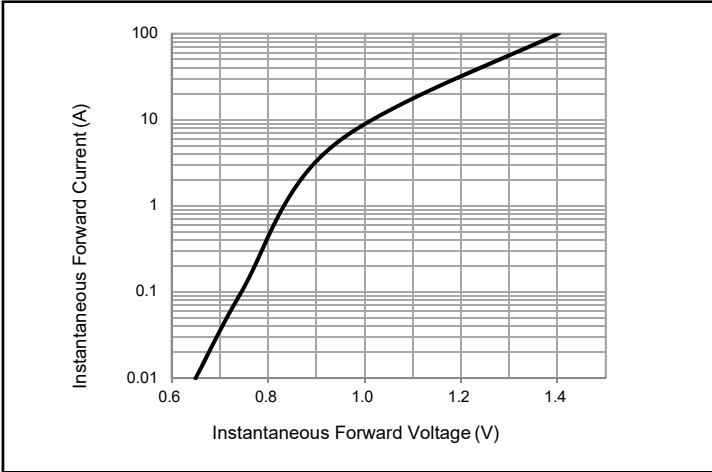

Fig. 3 - Typical Instantaneous Forward Characteristics

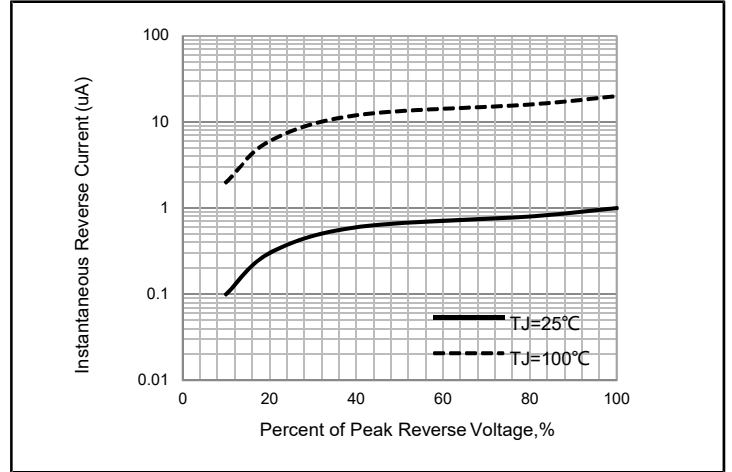

Fig. 4 - Typical Reverse Characteristics

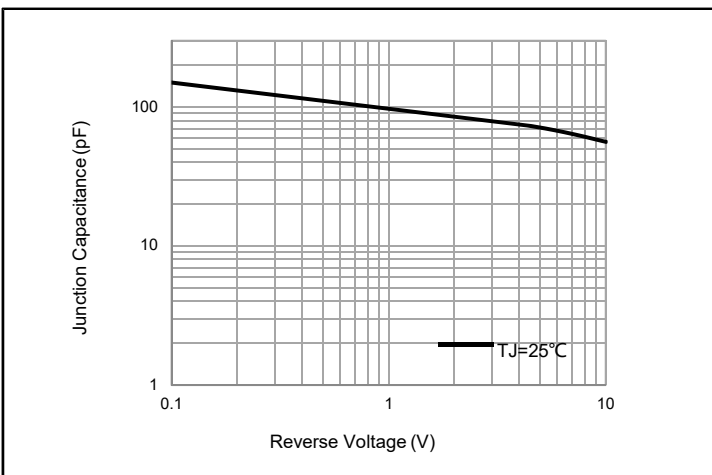

Fig. 5 - Typical Junction Capacitance

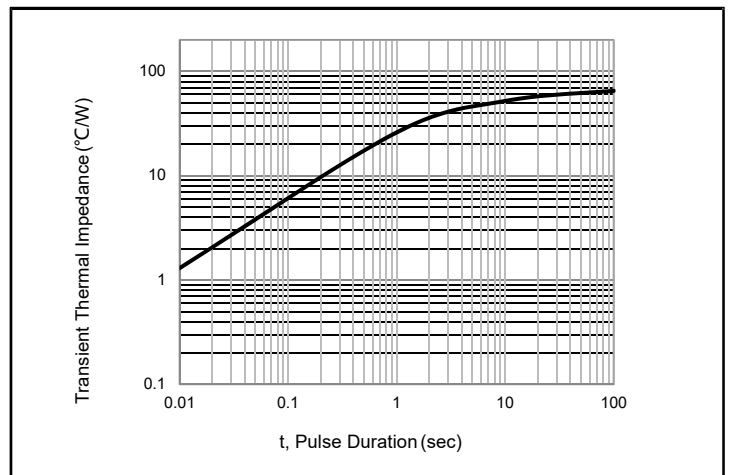
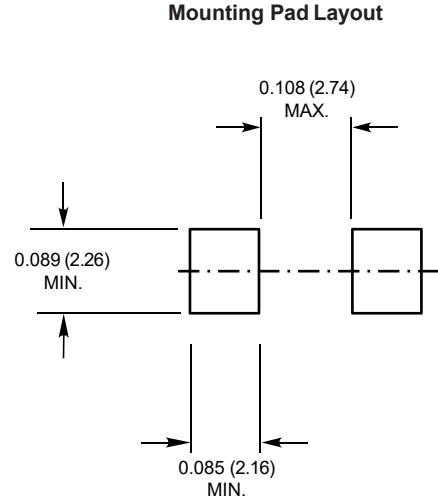
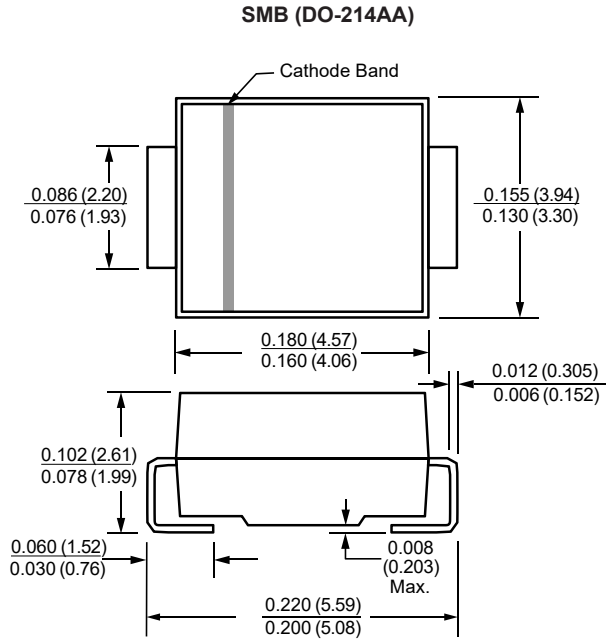
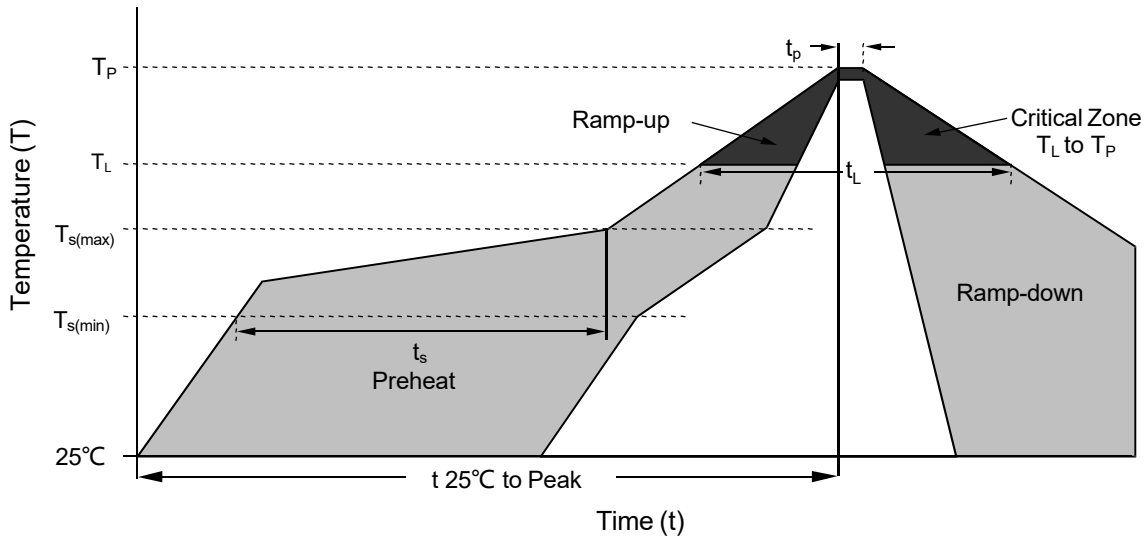

Fig. 6 - Typical Transient Thermal Impedance

**Package Outline Dimensions in inches (millimeters)**



Soldering Parameters



Reflow Condition		Lead-free assembly
Pre Heat	- Temperature Min ( $T_{s(min)}$ )	150°C
	- Temperature Max ( $T_{s(max)}$ )	200°C
	- Time (min to max) ( $t_s$ )	60 – 180 secs
Average ramp up rate (Liquidus Temp ( $T_L$ ) to peak)		3°C/second max
$T_{s(max)}$ to $T_L$ - Ramp-up Rate		3°C/second max
Reflow	- Temperature ( $T_L$ ) (Liquidus)	217°C
	- Time ( $t_L$ )	60 – 150 secs
Peak Temperature ( $T_P$ )		260 <sup>+0/-5</sup> °C
Time within 5°C of actual peak Temperature ( $t_p$ )		20 – 40 secs
Ramp-down Rate		6°C/second max
Time 25°C to peak Temperature (t)		8 minutes Max.
Do not exceed		260°C

Part Numbering System

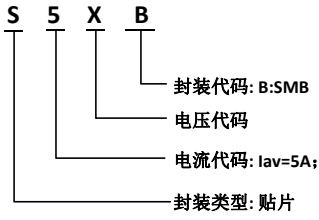

Part Marking System

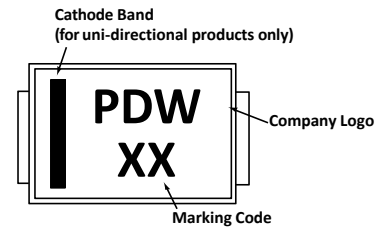

Summary of Packing Options

Package	Packing Description	Packing Quantity
SMB	Tape/Reel, 13" reel	3000

Tape and Reel Specification

