

ISSUE : March 9, 2020

TO ;

S P E C I F I C A T I O N S

Product Name PHOTOCOUPLER

Model No. PC817

【Business dealing name : PC817X**SZW】
(CHINA products)

These specifications contain 15 pages including the cover and appendix.
This specification sheets and attached sheets shall be both side copy.
After confirmation of the contents, please be sure to send back _____ copy of the
Specifications with approving signature on each.
If you have any objections, please contact us before issuing purchasing order.

Accepted by:

Sharp Corporation

By: _____

By: J. K

Name:

Name: T. Kamiyoshi

Title:

Title: Senior Manager

Date:

Electronic Components and Devices Account Div.

Date: Mar. 11, 2020

By: _____

Sharp Fukuyama Semiconductor Co., Ltd.

Name:

By: T. Ichinose

Title:

Name: T. Ichinose

Date:

Title: Division Manager

Sensor Development Div. II

Semiconductor Business Unit

Date: Mar. 11, 2020

Reviewed by:

Prepared by:

By: K. IBy: H. T

Name: K. Iwamoto

Name: H. Tanaka

Title: Senior Manager

Title: Supervisor

Date: Mar, 10, 2020Date: Mar, 10, 2020

1. These specification sheets include materials protected under copyright of Sharp Corporation ("Sharp"). Please handle with great care and do not reproduce or cause anyone to reproduce them without Sharp's consent.
2. When using this Sharp product, please observe the absolute maximum ratings, other conditions and instructions for use described in the specification sheets, as well as the precautions mentioned below.
Sharp assumes no responsibility for any damages resulting from use of the product which does not comply with absolute maximum ratings, other conditions and instructions for use included in the specification sheets, and the precautions mentioned below.

(Precautions)

- (1) In making catalogue or instruction manual based on the specification sheets, please verify the validity of the catalogue or instruction manuals after assembling Sharp products in customer's products at the responsibility of customer.
- (2) This Sharp product is designed for use in the following application areas ;
 - Computers • OA equipment • Telecommunication equipment (Terminal) • Measuring equipment
 - Tooling machines • Audio visual equipment • Home appliancesIf the use of the Sharp product in the above application areas is for equipment listed in paragraphs (3) or (4), please be sure to observe the precautions given in those respective paragraphs.
- (3) Appropriate measures, such as fail-safe design and redundant design considering the safety design of the overall system and equipment, should be taken to ensure reliability and safety when Sharp product is used for equipment in responsibility of customer which demands high reliability and safety in function and precision, such as ;
 - Transportation control and safety equipment (aircraft, train, automobile etc.)
 - Traffic signals • Gas leakage sensor breakers • Rescue and security equipment
 - Other safety equipment
- (4) Sharp product is designed for consumer goods and controlled as consumer goods in production and quality. Please do not use this product for equipment which require extremely high reliability and safety in function and precision, such as ;
 - Space equipment • Telecommunication equipment (for trunk lines)
 - Nuclear power control equipment • Medical equipment
- (5) Please contact and consult with a Sharp sales representative if there are any question regarding interpretation of the above four paragraphs.

3. Disclaimer

The warranty period for Sharp product is one (1) year after shipment.
During the period, if there are any products problem, Sharp will repair (if applicable), replace or refund.
Except the above, both parties will discuss to cope with the problems.

The failed Sharp product after the above one (1) year period will be coped with by Sharp, provided that both parties shall discuss and determine on sharing responsibility based on the analysis results thereof subject to the above scope of warranty.

The warranty described herein is only for Sharp product itself which are purchased by or delivered to customer.
Damages arising from Sharp product malfunction or failure shall be excepted.

Sharp will not be responsible for the Sharp product due to the malfunction or failures thereof which are caused by:

- (1) storage keep trouble during the inventory in the marketing channel.
- (2) intentional act, negligence or wrong/poor handling.
- (3) equipment which Sharp products are connected to or mounted in.
- (4) disassembling, reforming or changing Sharp products.
- (5) installation problem.
- (6) act of God or other disaster (natural disaster, fire, flood, etc.)
- (7) external factors (abnormal voltage, abnormal electromagnetic wave, fire, etc.)
- (8) special environment (factory, coastal areas, hot spring area, etc.)
- (9) phenomenon which cannot be foreseen based on the practical technologies at the time of shipment.
- (10) the factors not included in the product specification sheet.

4. Please contact and consult with a Sharp sales representative for any questions about Sharp product.

1. Application

This specification applies to the outline and characteristics of photocoupler Model No. PC817series.

2. Outline Refer to page 4.

3. Ratings and characteristics Refer to page 5 and 6.

4. Reliability Refer to page 7.

5. Outgoing inspection Refer to page 8.

6. Supplement

6.1 Isolation voltage shall be measured in the following method.

- (1) Short between anode and cathode on the primary side and between collector and emitter on the secondary side.
- (2) The dielectric withstanding tester with zero-cross circuit shall be used.
- (3) The wave form of applied voltage shall be a sine wave.

6.2 Package specifications Refer to page 9 and 10.

6.3 Business dealing name ("○" mark indicates business dealing name of ordered product)

Ordered product	Business dealing name	Rank mark	I _C (mA)	Remark
	PC817XNNSZW	with or without	2.5 to 30	
	PC817X1NSZW	A	4.0 to 8.0	
	PC817X2NSZW	B	6.5 to 13	
	PC817X3NSZW	C	10 to 20	
	PC817XNYSZW	with or without	2.5 to 30	Applied to product as an option (Attachment-2-1 to 2-3.)
	PC817X1YSZW	A	4.0 to 8.0	
	PC817X2YSZW	B	6.5 to 13	
	PC817X3YSZW	C	10 to 20	

Test conditions

I_F=5mA
V_{CE}=5V
T_a=25°C

6.4 This Model is approved by UL. (Under preparation)

Approved Model No. : PC817

UL file No. : E64380

6.5 This Model is approved by CSA. (Under preparation)

Approved Model No. : PC817

CSA approved mark "  " shall be indicated on minimum unit package.

6.6 About radiation resistant design

- (1) This product is not designed against irradiation.
- (2) This product is assembled with electrical input and output.
- (3) This product incorporates non-coherent light emitting diode.

6.7 ODS materials

- (1) This product shall not contain the following materials.
- (2) Also, the following materials shall not be used in the production process for this product.
Materials for ODS: CFCs, Halon, Carbon tetrachloride, 1.1.1-Trichloroethane (Methyl chloroform)

6.8 Specified brominated flame retardants

Specified brominated flame retardants (PBB and PBDE) are not used in this device at all.

6.9 Compliance with each regulation

(1) This product complies with EU RoHS Directive (2011/65/EU) and Commission Delegated Directive (EU)2015/863.

(2) Content of six substances specified in Management Methods for Control of Pollution Caused by Electronic Information Products Regulation (Chinese : 电子信息产品污染控制管理办法).

Marking Styles for the Names and Contents of the Hazardous Substances

Category	Hazardous Substances					
	Lead (Pb)	Mercury (Hg)	Cadmium (Cd)	Hexavalent chromium (Cr ⁶⁺)	Polybrominated biphenyls (PBB)	Polybrominated diphenyl ethers (PBDE)
Photocoupler	○	○	○	○	○	○

This table is prepared in accordance with the provisions of SJ/T 11364.

○ : Indicates that said hazardous substance contained in all of the homogeneous materials for this part is below the limit requirement of GB/T 26572.

7. Notes

Precautions for photocouplers: Attachment-1

(Notice)

The contents described herein are subject to change without notice for improvement since this product is under development.

2. Outline

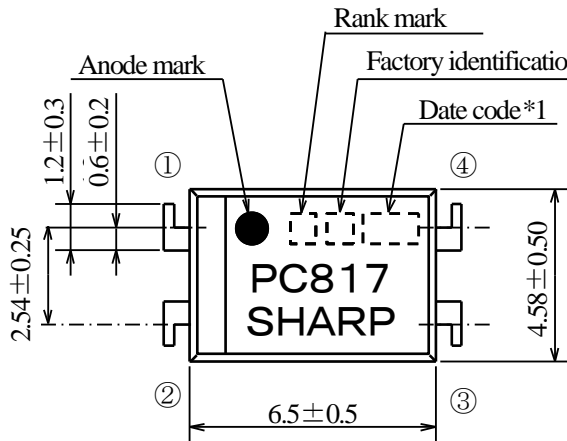

Pin-Number and internal connection diagram

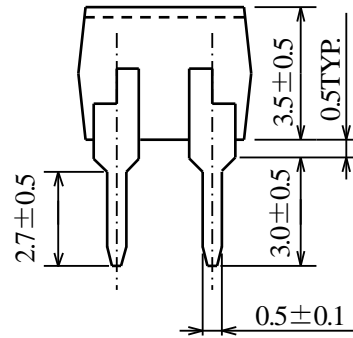
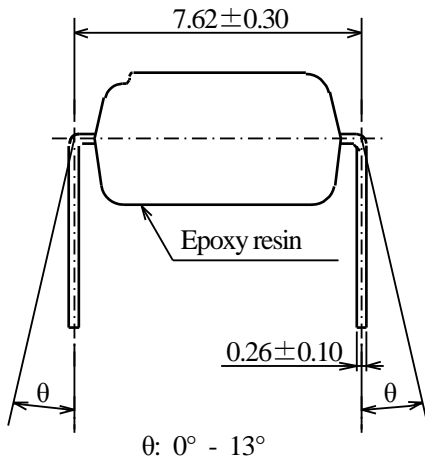
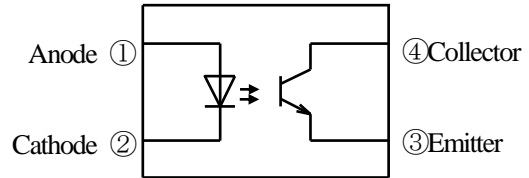

*1) Date code : 3 digit indication according to production year, month and day

*2) Factory identification mark apply to the below

H : YONGYAO ENSEI ELECTRONICS [SHANGQIU] Co., Ltd. (CHINA products)

Pin material : Copper Alloy

Pin finish : Palladium (Au Flash plating)

Mark : Laser marking

Product mass : Approx. 0.23g

UNIT : mm	
Name	PC817 Outline Dimensions (Business dealing name : PC817X*NSZW)

3. Ratings and characteristics

3.1 Absolute maximum ratings

Ta=25°C

Parameter		Symbol	Rating	Unit
Input	*1 Forward current	I_F	50	mA
	*2 Peak forward current	I_{FM}	1	A
	Reverse voltage	V_R	6	V
	*1 Power dissipation	P	70	mW
Output	Collector-emitter voltage	V_{CEO}	80	V
	Emitter-collector voltage	V_{ECO}	6	V
	Collector current	I_C	50	mA
	*1 Collector power dissipation	P_C	150	mW
*1 Total power dissipation	P_{tot}	200	mW	
Operating temperature		T_{opr}	-30 to +100	°C
Storage temperature		T_{stg}	-55 to +125	°C
*3 Isolation voltage	$V_{iso(rms)}$	5	kV	
*4 Soldering temperature	T_{sol}	270	°C	

*1 The derating factors of absolute maximum ratings due to ambient temperature are shown in Fig. 1 to 4.

*2 Pulse width $\leq 100\mu s$, Duty ratio : 0.001 (Refer to Fig. 5)

*3 AC for 1 min, 40 to 60%RH

*4 For 10 s

3.2 Electro-optical characteristics

Ta=25°C

Parameter		Symbol	Condition	MIN.	TYP.	MAX.	Unit
Input	Forward voltage	V_F	$I_F=20mA$	-	1.2	1.4	V
	Peak forward voltage	V_{FM}	$I_{FM}=0.5A$	-	-	3.0	V
	Reverse current	I_R	$V_R=4V$	-	-	10	μA
	Terminal capacitance	C_t	$V=0, f=1kHz$	-	30	250	pF
Output	Dark current	I_{CEO}	$V_{CE}=50V, I_F=0$	-	-	100	nA
	Collector-emitter breakdown voltage	BV_{CEO}	$I_C=0.1mA, I_F=0$	80	-	-	V
	Emitter-collector breakdown voltage	BV_{ECO}	$I_E=10\mu A, I_F=0$	6	-	-	V
Transfer characteristics	Collector current	I_C	$I_F=5mA, V_{CE}=5V$	2.5	-	30	mA
	Collector-emitter saturation voltage	$V_{CE(sat)}$	$I_F=20mA, I_C=1mA$	-	0.1	0.2	V
	Isolation resistance	R_{ISO}	DC500V, 40 to 60%RH	5×10^{10}	10^{11}	-	Ω
	Floating capacitance	C_f	$V=0, f=1MHz$	-	0.6	1.0	pF
	Cut-off frequency	f_c	$V_{CE}=5V, I_C=2mA$ $R_L=100\Omega, -3dB$	-	80	-	kHz
	Rise time	t_r	$V_{CE}=2V, I_C=2mA$	-	4	18	μs
	Fall time	t_f	$R_L=100\Omega$	-	3	18	μs

(Fig. 1) Forward current vs. Ambient temperature

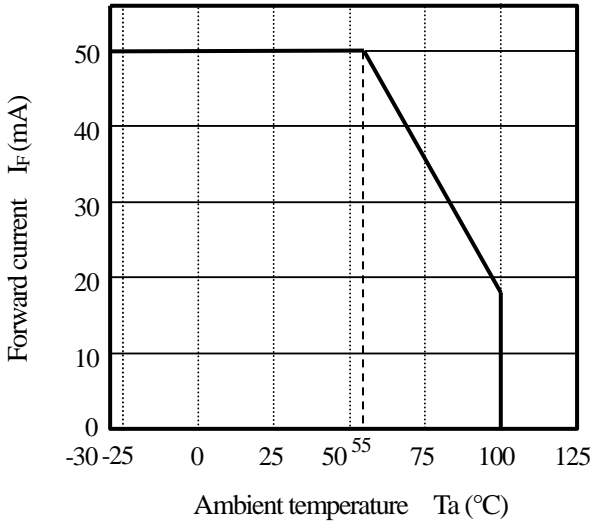

(Fig. 2) Diode power dissipation vs. Ambient temperature

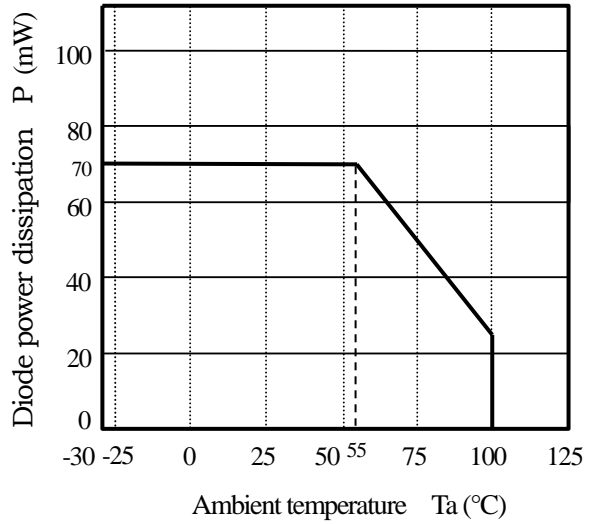

(Fig. 3) Collector power dissipation vs. Ambient temperature

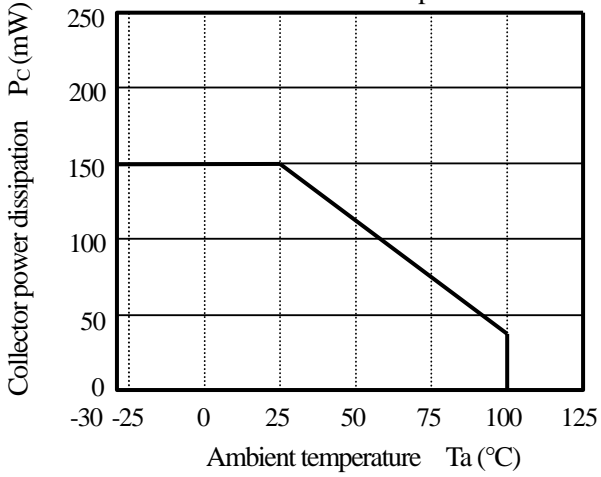

(Fig. 4) Total power dissipation vs. Ambient temperature

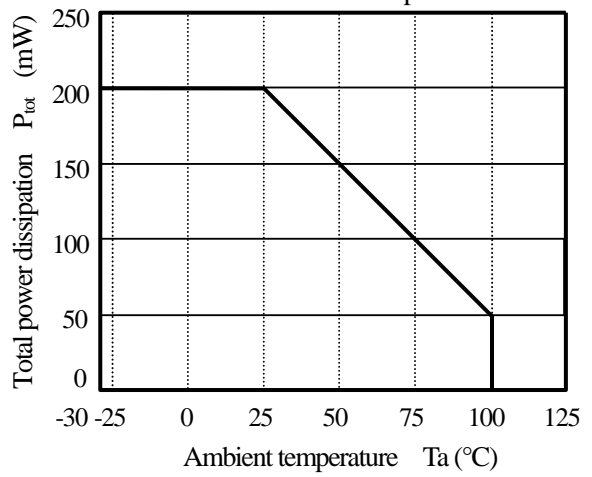

(Fig. 5) Peak forward current vs. Duty ratio
Pulse width $\leq 100\mu s$
 $T_a = 25^\circ C$

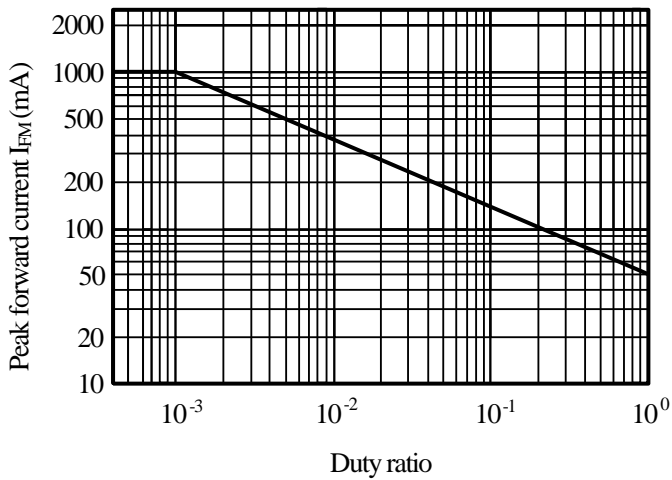

4. Reliability

The reliability of products shall satisfy items listed below.

Confidence level : 90%

LTPD : 10 or 20

Test Items	Condition *1	Failure Judgment Criteria	Samples (n) Defective (C)
Solderability	245±3°C, 5s	*2	n=11, C=0
Soldering heat	(Flow soldering) 270°C, 10s	$V_F > U \times 1.2$ $I_R > U \times 2$ $I_{CEO} > U \times 2$ $I_C < L \times 0.7$ $V_{CE(sat)} > U \times 1.2$ U: Upper specification limit L: Lower specification limit	n=11, C=0
	(Soldering by hand) 400°C, 3s		n=11, C=0
Terminal strength (Tension)	Weight: 5N, 5s/each terminal		n=11, C=0
Terminal strength (Bending) *3	Weight: 2.5N, 2 times/each terminal		n=11, C=0
Mechanical shock	15km/s ² , 0.5ms, 3 times/±X, ±Y, ±Z direction		n=11, C=0
Variable frequency vibration	100 to 2000 to 100Hz/4 min 200m/s ² 4 times/X, Y, Z direction		n=11, C=0
Temperature cycling	1 cycle -55°C to +125 °C (30 min) (30 min) 20 cycles test		n=22, C=0
High temp. and high humidity storage	+85°C, 85%RH, 1000h		n=22, C=0
High temp. storage	+125°C, 1000h		n=22, C=0
Low temp. storage	-55°C, 1000h		n=22, C=0
Operation life	$I_F=50mA$, $P_{tot}=200mW$ $T_a=25°C$, 1000h		n=22, C=0

*1 Test method, conforms to EIAJ ED 4701.

*2 The product whose not-soldered area is more than 5% for all of the dipped area, and/or whose pinholes or voids are concentrated on one place shall be judged defect.

*3 Terminal bending direction is shown below.

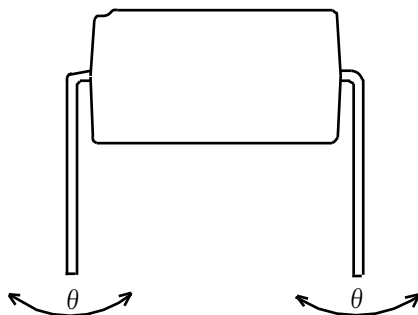

※ These test results are sampling examples from a specific lot for reference purpose only, and do not constitute any warranty or assurance in connection with the products.

5. Outgoing inspection

5.1 Inspection items

(1) Electrical characteristics

V_F , I_R , I_{CEO} , $V_{CE(sat)}$, I_C , R_{ISO} , V_{iso}

(2) Appearance

5.2 Sampling method and Inspection level

A single sampling plan, normal inspection level II based on ISO 2859 is applied.

The AQL according to the items are shown below.

Defect	Inspection item	AQL (%)
Major defect	Electrical characteristics Unreadable marking	0.065
Minor defect	Appearance defect except the above mentioned.	0.25

6.2 Package specification

6.2.1 Package materials

No.	Name	Materials	Purposes
①	Sleeve	HIPS or ABS with preventing static electricity	Products packaged
②	Stopper	Styrene - Erastomer	Products fixed
③	Packing case	Corrugated cardboard	Sleeve packaged
④	Kraft tape	Paper	Lid of packing case fixed
⑤	Label	Paper	Model No., (Business dealing name), Lot No., Quantity, Country of origin, Company name and Inspection date specified

6.2.2 Package method

- (1) MAX. 100pcs. of products shall be packaged in a sleeve ① and both of sleeve edges shall be fixed by stoppers ②.
- (2) MAX. 20 sleeves (Product: 2000pcs.) above shall be packaged in a packing case ③.
- (3) The label ⑤ shall be put on the side of the packing case.
- (4) Case shall be closed with the lid and enclosed with kraft tape ④.

6.2.3 Sleeve ① outline dimensions

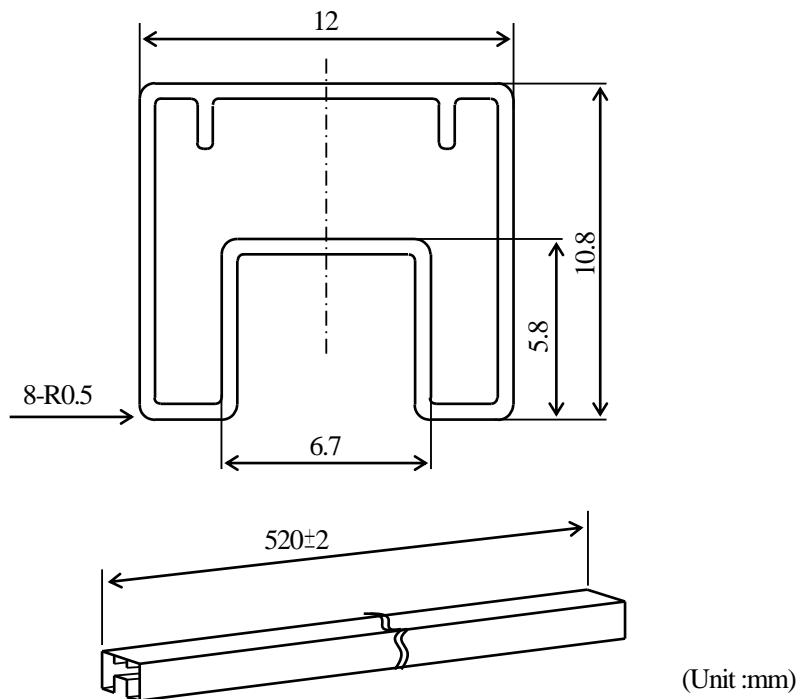

- Note
- 1) Thickness : 0.5 ± 0.2 mm
 - 2) Process with applying antistatic agent.
 - 3) Unless otherwise specified tolerances shall be ± 0.5 mm.
(However except for deformation due to the stopper in sleeve.)

6.2.4 Packing outer case outline dimensions

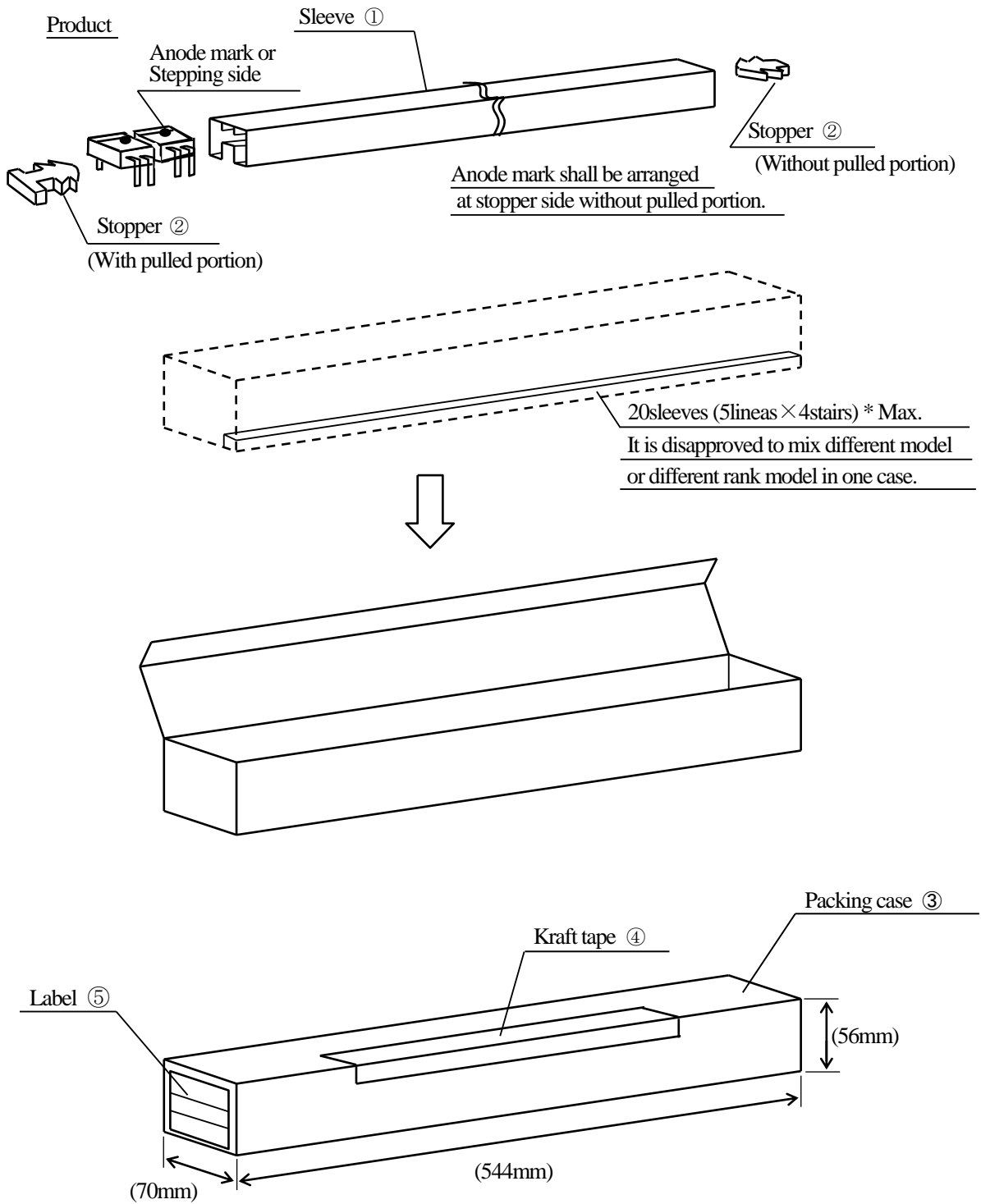

Regular packing mass : Approx. 860g

() : Reference dimensions

Precautions for Photocouplers

1. Cleaning

- (1) Solvent cleaning : Solvent temperature 45°C or less
Immersion for 3 min or less
- (2) Ultrasonic cleaning : The effect to device by ultrasonic cleaning differs by cleaning bath size, ultrasonic power output, cleaning time, PCB size or device mounting condition etc. Please test it in actual using condition and confirm that any defect doesn't occur before starting the ultrasonic cleaning.
- (3) Applicable solvent : Ethyl alcohol, Methyl alcohol, Isopropyl alcohol
When the other solvent is used, there are cases that the packaging resin is eroded.
Please use the other solvent after thorough confirmation is performed in actual using condition.

2. Circuit design

- (1) The LED used in the Photocoupler generally decreases the light emission power by operation.
In case of long operation time, please design the circuit in consideration of the degradation of the light emission power of the LED. (50%/5years)
- (2) There are cases that the deviation of the IC and the degradation of the relative light emission power of the LED increase when the setting value of I_F is less than 1.0mA. Please design the circuit in consideration of this point.

3. Precautions for Soldering

- (1) In the case of flow soldering (Whole dipping is possible)
It is recommended that flow soldering should be at 270°C or less for 10 s or less
(Pre-heating: 100°C to 150°C, 30 s to 80 s). (2 times or less)
- (2) In the case of hand soldering
What is done on the following condition is recommended. (2 times or less)
Soldering iron temperature : 400°C or less
Time : 3 s or less
- (3) Other precautions
Depending on equipment and soldering conditions (temperature, Using solder etc.), the effect to the device and the PCB is different. Please confirm that there is no problem on the actual use conditions in advance.

1. This specification shall be applied to photocoupler, Model No. PC817 as an option.
2. Applicable Models (Business dealing name)
PC817XNYSZW, PC817X1YSZW, PC817X2YSZW, PC817X3YSZW

3. The relevant models are the models approved by VDE according to DIN EN 60747-5-5. (Under preparation)
Approved Model No. : PC817

VDE approved No. : 40008087 (According to the specification DIN EN60747-5-5)

- Operating isolation voltage V_{IORM} : 890V (Peak)
- Transient voltage : 9000V (Peak)
- Pollution : 2
- Clearances distance (Between input and output) : 6.4mm (MIN.)
- Creepage distance (Between input and output) : 6.4mm (MIN.)
- Tracking-proof : CTI 175
- Safety limit values
 - Current (Isi) : 200mA (Diode side)
 - Power (Psi) : 300mW (Phototransistor side)
 - Temperature (Tsi) : 150°C

In order to keep safety electric isolation of photocoupler, please set the protective circuit to keep within safety limit values when the actual application equipment troubled.

- Indication of VDE approval "  " is printed on minimum unit package.

4. Outline Refer to the attachment-2-2.

5. Isolation specification according to EN60747-5-5

Parameter	Symbol	Condition	Rating	Unit	Remark									
Class of environmental test	-	-	55/100/21	-										
Pollution	-	-	2	-										
Maximum operating isolation voltage	V_{IORM} (PEAK)	-	890	V	Refer to the Diagram 1, 2 (Attachement-2-3)									
Partial discharge test voltage (Between input and output)														
<table border="1" style="width: 100%;"> <tr> <td>Diagram 1</td> <td>V_m</td> <td>$tp=10s, qc<=5pC$</td> <td>1430</td> <td>V</td> </tr> <tr> <td>Diagram 2</td> <td>(PEAK)</td> <td>$tp=1s, qc<=5pC$</td> <td>1670</td> <td>V</td> </tr> </table>	Diagram 1	V_m	$tp=10s, qc<=5pC$	1430		V	Diagram 2	(PEAK)	$tp=1s, qc<=5pC$	1670	V			
Diagram 1	V_m	$tp=10s, qc<=5pC$	1430	V										
Diagram 2	(PEAK)	$tp=1s, qc<=5pC$	1670	V										
Maximum over-voltage	$V_{ini,a}$ (PEAK)	$t_{NI}=60s$	9000	V										
Safety maximum ratings					Refer to Fig. 6, 7 (Attachement-2-3)									
1) Case temperature	T_{si}	$I_F=0, P_C=0$	150	°C										
2) Input current	I_{si}	$P_C=0$	200	mA										
3) Electric power (Output or Total power dissipation)	P_{si}	-	300	mW										
Isolation resistance (Test voltage between input and output ; DC500V)	R_{ISO}	$T_a=T_{si}$	MIN. 10^9	Ω										
		$T_a=100^\circ C$	MIN. 10^{11}											
		$T_a=25^\circ C$	MIN. 10^{12}											

6. Precautions in performing isolation test

6.1 Partial discharge test methods shall be the ones according to the specifications of EN 60747-5-5

6.2 Please don't carry out isolation test (V_{iso}) over $V_{ini,a}$.

This product deteriorates isolation characteristics by partial discharge due to applying high voltage. And there is possibility that partial discharge occurs in operating isolation voltage. (V_{IORM}).

2. Outline

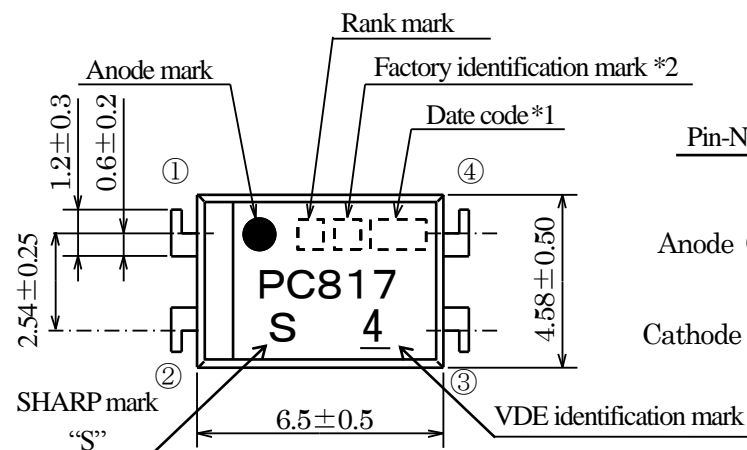

Pin-Number and internal connection diagram

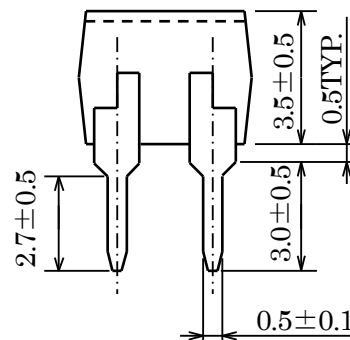
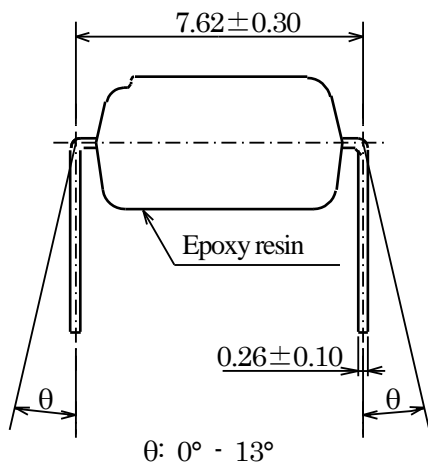
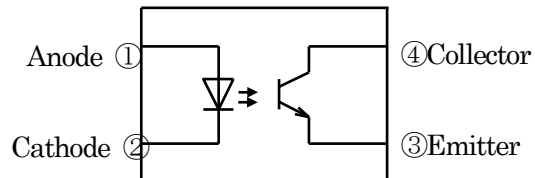

*1) Date code : 3 digit indication according to production year, month and day

*2) Factory identification mark apply to the below

H : YONGYAO ENSEI ELECTRONICS [SHANGQIU] Co., Ltd. (CHINA products)

Pin material : Copper Alloy

Pin finish : Palladium (Au Flash plating)

Mark : Laser marking

Product mass : Approx. 0.23g

UNIT : mm	
Name	PC817 Outline Dimensions (Business dealing name : PC817X*YSZW)

Method of Diagram 1: Breakdown test (Apply to type test and sampling test)

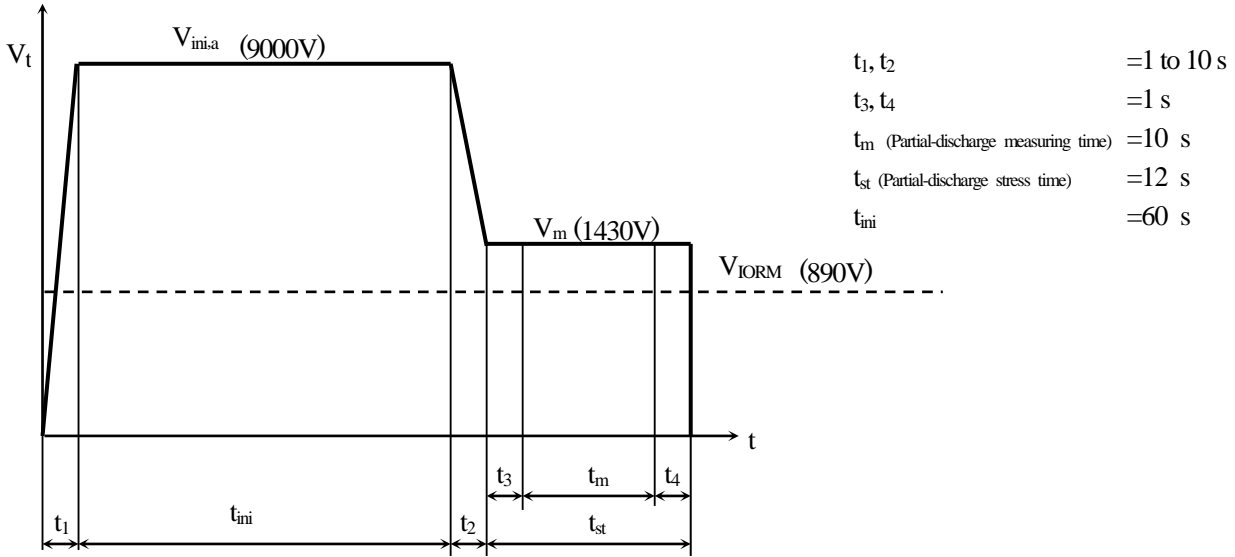

Method of Diagram 2: Non breakdown test (Apply to all device test)

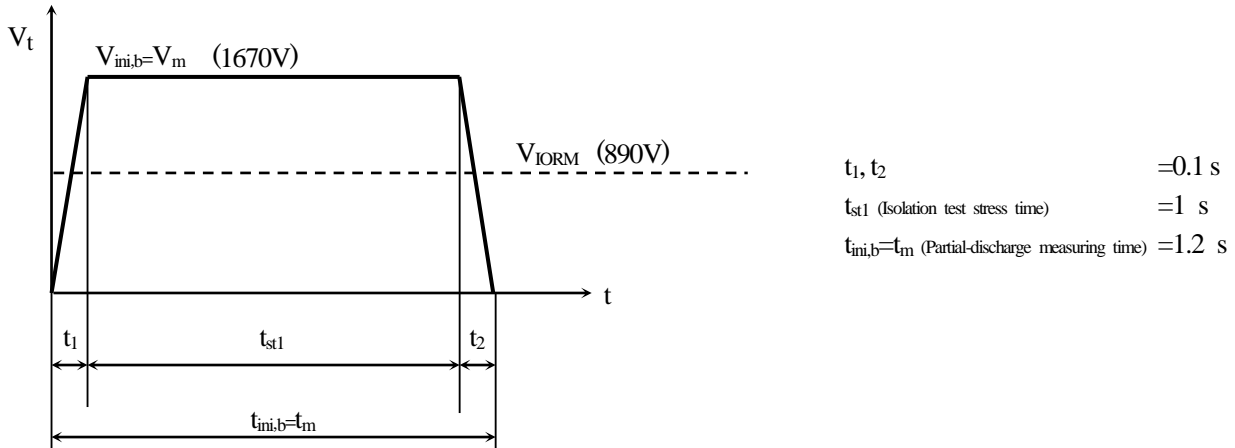

(Fig.6) Safety maximum power dissipation vs. ambient temperature (When failed)

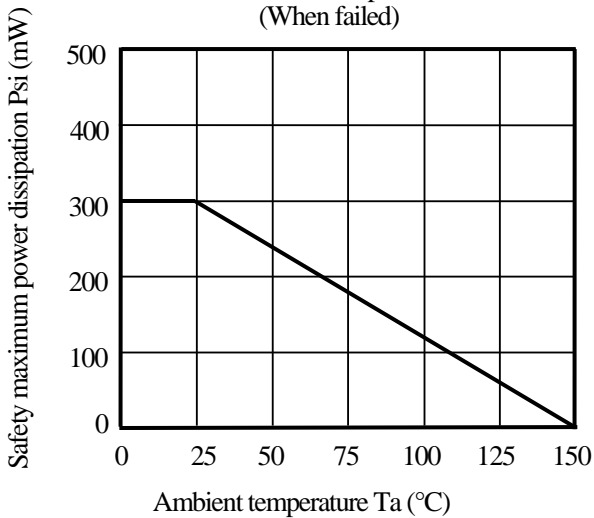

(Fig. 7) Safety maximum forward current vs. ambient temperature (When failed)

