

INAx180 Low- and High-Side Voltage Output, Current-Sense Amplifiers

1 Features

- Common-Mode Range (V_{CM}): -0.2 V to $+26\text{ V}$
- High Bandwidth: 350 kHz (A1 Devices)
- Offset Voltage:
 - $\pm 150\ \mu\text{V}$ (Max) at $V_{CM} = 0\text{ V}$
 - $\pm 500\ \mu\text{V}$ (Max) at $V_{CM} = 12\text{ V}$
- Output Slew Rate: $2\text{ V}/\mu\text{s}$
- Accuracy:
 - $\pm 1\%$ Gain Error (Max)
 - $1\text{-}\mu\text{V}/^\circ\text{C}$ Offset Drift (Max)
- Gain Options:
 - 20 V/V (A1 Devices)
 - 50 V/V (A2 Devices)
 - 100 V/V (A3 Devices)
 - 200 V/V (A4 Devices)
- Quiescent Current: 260 μA Max (INA180)

2 Applications

- Motor Control
- Battery Monitoring
- Power Management
- Lighting Control
- Overcurrent Detection
- Solar Inverters

3 Description

The INA180, INA2180, and INA4180 (INAx180) current sense amplifiers are designed for cost-optimized applications. These devices are part of a family of current-sense amplifiers (also called current-shunt monitors) that sense voltage drops across current-sense resistors at common-mode voltages from -0.2 V to $+26\text{ V}$, independent of the supply voltage. The INAx180 integrate a matched resistor gain network in four, fixed-gain device options: 20 V/V, 50 V/V, 100 V/V, or 200 V/V. This matched gain resistor network minimizes gain error and reduces the temperature drift.

All these devices operate from a single 2.7-V to 5.5-V power supply. The single-channel INA180 draws a maximum supply current of 260 μA ; whereas, the dual-channel INA2180 draws a maximum supply current of 500 μA , and the quad channel draws a maximum supply current of 900 μA .

The INA180 is available in a 5-pin, SOT-23 package with two different pin configurations. The INA2180 is available in an 8-pin VSSOP package. The INA4180 is available in a 14-pin TSSOP package. All device options are specified over the extended operating temperature range of -40°C to $+125^\circ\text{C}$.

Device Information⁽¹⁾

PART NUMBER	PACKAGE	BODY SIZE (NOM)
INA180	SOT-23 (5)	2.90 mm x 1.60 mm
INA2180	VSSOP (8)	3.00 mm x 3.00 mm
INA4180	TSSOP (14)	5.00 mm x 4.40 mm

(1) For all available packages, see the package option addendum at the end of the datasheet.

Typical Application Circuit

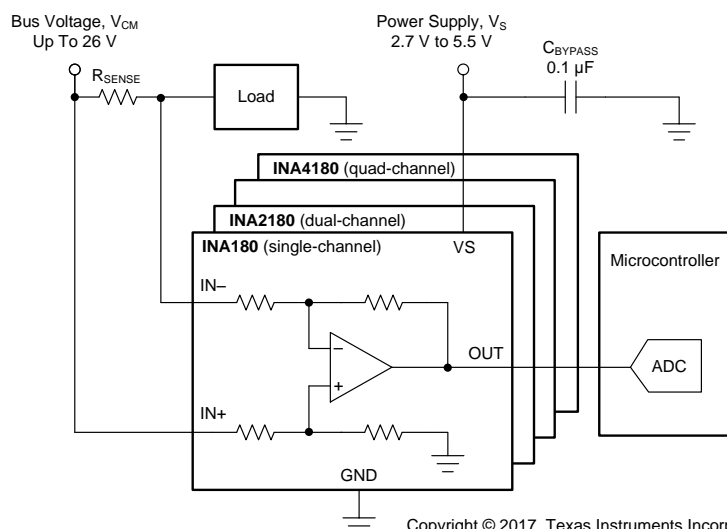

Copyright © 2017, Texas Instruments Incorporated



Table of Contents

1 Features	1	9 Application and Implementation	20
2 Applications	1	9.1 Application Information.....	20
3 Description	1	9.2 Typical Application	24
4 Revision History	2	10 Power Supply Recommendations	26
5 Device Comparison Table	4	10.1 Common-Mode Transients Greater Than 26 V	26
6 Pin Configurations and Functions	4	11 Layout	27
7 Specifications	6	11.1 Layout Guidelines	27
7.1 Absolute Maximum Ratings	6	11.2 Layout Examples.....	27
7.2 ESD Ratings.....	6	12 Device and Documentation Support	30
7.3 Recommended Operating Conditions.....	6	12.1 Documentation Support	30
7.4 Thermal Information	6	12.2 Related Links	30
7.5 Electrical Characteristics.....	7	12.3 Receiving Notification of Documentation Updates	30
7.6 Typical Characteristics	8	12.4 Community Resources.....	30
8 Detailed Description	15	12.5 Trademarks	30
8.1 Overview	15	12.6 Electrostatic Discharge Caution.....	30
8.2 Functional Block Diagrams	15	12.7 Glossary	30
8.3 Feature Description.....	17	13 Mechanical, Packaging, and Orderable	
8.4 Device Functional Modes.....	18	Information	31

4 Revision History

Changes from Revision C (December 2017) to Revision D	Page
• Changed INA4180 device from preview to production data (active)	1
• Added new Figure 25 for INA4180	11
• Added new Figure 28 for INA4180	11

Changes from Revision B (November 2017) to Revision C	Page
• Changed INA2180 device from preview to production data (active)	1
• Added "Both Inputs" to Figure 21 title	10
• Added new Figure 24 for INA2180	10
• Added new Figure 25 placeholder for INA4180	11
• Added new Figure 27 for INA2180	11
• Added new Figure 28 placeholder for INA4180	11
• Changed Figure 29.....	11
• Added "(A3 Devices)" to end of Figure 29 title	11
• Added new Figure 38 for INA2180	13
• Changed "less than 150 μ V" to "within \pm 150 μ V" regarding offset voltage in <i>Precise Low-Side Current Sensing</i> section..	17
• Added text regarding RC filter and reference to application report to note at the bottom of Figure 45	20
• Deleted V_S from Equation 2	21
• Added equation and curve for f_{-3dB} to Figure 46	22
• Added link to reference design TIDA-00302 to end of <i>Common-Mode Transients Greater Than 26 V</i> section.....	26
• Added new bullet to <i>Layout Guidelines</i> section.....	27

Changes from Revision A (August 2017) to Revision B**Page**

- Added INA4180 preview device and associated content to data sheet 1
 - Changed design parameter name in Table 3 from "Accuracy" to "Current sensing error" for clarity 24
 - Changed "RMS" to "RSS" in reference to equation 7 25
-

Changes from Original (April 2017) to Revision A**Page**

- Added INA2180 preview device and associated content to data sheet 1
-

5 Device Comparison Table

PRODUCT	NUMBER OF CHANNELS	GAIN (V/V)
INA180A1	1	20
INA180A2	1	50
INA180A3	1	100
INA180A4	1	200
INA2180A1	2	20
INA2180A2	2	50
INA2180A3	2	100
INA2180A4	2	200
INA4180A1	4	20
INA4180A2	4	50
INA4180A3	4	100
INA4180A4	4	200

6 Pin Configurations and Functions

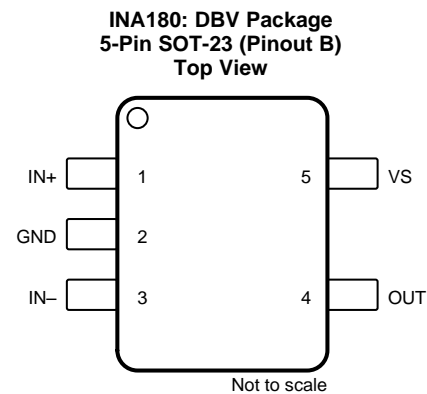
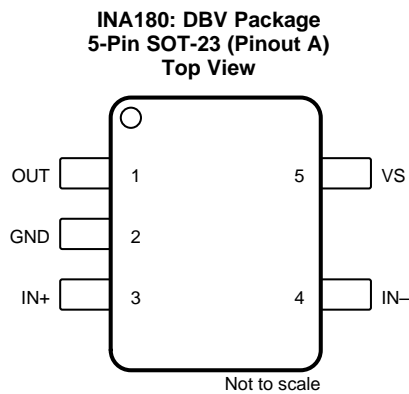

Pin Functions: INA180 (Single Channel)

NAME	PIN		I/O	DESCRIPTION
	SOT-23 Pinout A	SOT-23 Pinout B		
GND	2	2	Analog	Ground
IN-	4	3	Analog input	Current-sense amplifier negative input. For high-side applications, connect to load side of sense resistor. For low-side applications, connect to ground side of sense resistor.
IN+	3	1	Analog input	Current-sense amplifier positive input. For high-side applications, connect to bus-voltage side of sense resistor. For low-side applications, connect to load side of sense resistor.
OUT	1	4	Analog output	Output voltage
VS	5	5	Analog	Power supply, 2.7 V to 5.5 V

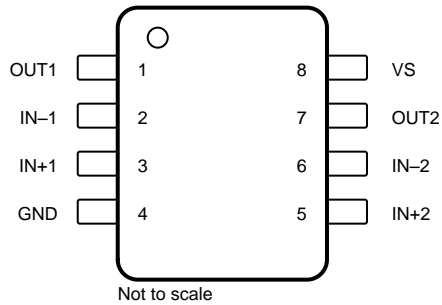
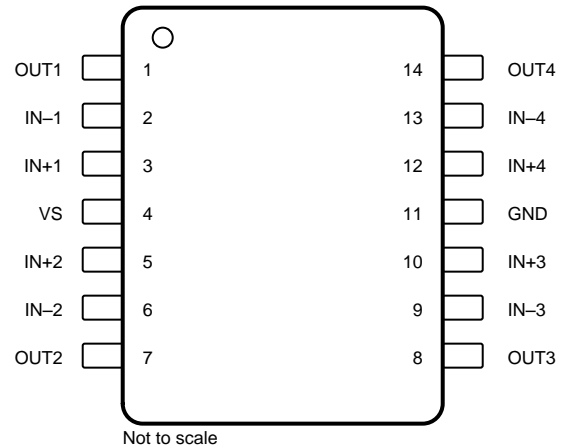
**INA2180: DGK Package
8-Pin VSSOP
Top View**

**INA4180: PW Package
14-Pin TSSOP
Top View**

Pin Functions: INA2180 (Dual Channel) and INA4180 (Quad Channel)

NAME	PIN		I/O	DESCRIPTION
	INA2180	INA4180		
GND	4	11	Analog	Ground
IN-1	2	2	Analog input	Current-sense amplifier negative input for channel 1. For high-side applications, connect to load side of channel-1 sense resistor. For low-side applications, connect to ground side of channel-1 sense resistor.
IN+1	3	3	Analog input	Current-sense amplifier positive input for channel 1. For high-side applications, connect to bus-voltage side of channel-1 sense resistor. For low-side applications, connect to load side of channel-1 sense resistor.
IN-2	6	6	Analog input	Current-sense amplifier negative input for channel 2. For high-side applications, connect to load side of channel-2 sense resistor. For low-side applications, connect to ground side of channel-2 sense resistor.
IN+2	5	5	Analog input	Current-sense amplifier positive input for channel 2. For high-side applications, connect to bus-voltage side of channel-2 sense resistor. For low-side applications, connect to load side of channel-2 sense resistor.
IN-3	—	9	Analog input	Current-sense amplifier negative input for channel 3. For high-side applications, connect to load side of channel-3 sense resistor. For low-side applications, connect to ground side of channel-3 sense resistor.
IN+3	—	10	Analog input	Current-sense amplifier positive input for channel 3. For high-side applications, connect to bus-voltage side of channel-3 sense resistor. For low-side applications, connect to load side of channel-3 sense resistor.
IN-4	—	13	Analog input	Current-sense amplifier negative input for channel 4. For high-side applications, connect to load side of channel-4 sense resistor. For low-side applications, connect to ground side of channel-4 sense resistor.
IN+4	—	12	Analog input	Current-sense amplifier positive input for channel 4. For high-side applications, connect to bus-voltage side of channel-4 sense resistor. For low-side applications, connect to load side of channel-4 sense resistor.
OUT1	1	1	Analog output	Channel 1 output voltage
OUT2	7	7	Analog output	Channel 2 output voltage
OUT3	—	8	Analog output	Channel 3 output voltage
OUT4	—	14	Analog output	Channel 4 output voltage
VS	8	4	Analog	Power supply, 2.7 V to 5.5 V

7 Specifications

7.1 Absolute Maximum Ratings

over operating free-air temperature range (unless otherwise noted)⁽¹⁾

		MIN	MAX	UNIT
Supply voltage, V_S			6	V
Analog inputs, IN+, IN- ⁽²⁾	Differential ($V_{IN+} - V_{IN-}$)	-26	26	V
	Common-mode ⁽³⁾	GND - 0.3	26	
Output voltage		GND - 0.3	$V_S + 0.3$	V
Maximum output current, I_{OUT}			8	mA
Operating free-air temperature, T_A		-55	150	°C
Junction temperature, T_J			150	°C
Storage temperature, T_{stg}		-65	150	°C

- (1) Stresses beyond those listed under *Absolute Maximum Ratings* may cause permanent damage to the device. These are stress ratings only, which do not imply functional operation of the device at these or any other conditions beyond those indicated under *Recommended Operating Conditions*. Exposure to absolute-maximum-rated conditions for extended periods may affect device reliability.
- (2) V_{IN+} and V_{IN-} are the voltages at the IN+ and IN- pins, respectively.
- (3) Input voltage at any pin can exceed the voltage shown if the current at that pin is limited to 5 mA.

7.2 ESD Ratings

		VALUE	UNIT
$V_{(ESD)}$ Electrostatic discharge	Human-body model (HBM), per ANSI/ESDA/JEDEC JS-001 ⁽¹⁾	±3000	V
	Charged-device model (CDM), per JEDEC specification JESD22-C101 ⁽²⁾	±1000	

- (1) JEDEC document JEP155 states that 500-V HBM allows safe manufacturing with a standard ESD control process.
- (2) JEDEC document JEP157 states that 250-V CDM allows safe manufacturing with a standard ESD control process.

7.3 Recommended Operating Conditions

		MIN	NOM	MAX	UNIT
V_{CM}	Common-mode input voltage (IN+ and IN-)	-0.2	12	26	V
V_S	Operating supply voltage	2.7	5	5.5	V
T_A	Operating free-air temperature	-40		125	°C

7.4 Thermal Information

THERMAL METRIC ⁽¹⁾		INA180	INA2180	INA4180	UNIT
		DBV (SOT-23)	DGK (VSSOP)	PW (TSSOP)	
		6 PINS	8 PINS	20 PINS	
$R_{\theta JA}$	Junction-to-ambient thermal resistance	197.1	177.9	115.9	°C/W
$R_{\theta JC(top)}$	Junction-to-case (top) thermal resistance	95.8	65.6	44.3	°C/W
$R_{\theta JB}$	Junction-to-board thermal resistance	53.1	99.3	59.2	°C/W
Ψ_{JT}	Junction-to-top characterization parameter	23.4	10.5	4.7	°C/W
Ψ_{JB}	Junction-to-board characterization parameter	52.7	97.9	58.6	°C/W
$R_{\theta JC(bot)}$	Junction-to-case (bottom) thermal resistance	N/A	N/A	N/A	°C/W

- (1) For more information about traditional and new thermal metrics, see the [Semiconductor and IC Package Thermal Metrics](#) application report.

7.5 Electrical Characteristics

at $T_A = 25^\circ\text{C}$, $V_S = 5\text{ V}$, $V_{IN+} = 12\text{ V}$, and $V_{SENSE} = V_{IN+} - V_{IN-}$ (unless otherwise noted)

PARAMETER		CONDITIONS	MIN	TYP	MAX	UNIT	
INPUT							
CMRR	Common-mode rejection ratio, RTI ⁽¹⁾	$V_{IN+} = 0\text{ V to } 26\text{ V}$, $V_{SENSE} = 10\text{ mV}$, $T_A = -40^\circ\text{C to } +125^\circ\text{C}$	84	100		dB	
V_{OS}	Offset voltage ⁽²⁾ , RTI	$V_{IN+} = 0\text{ V}$		± 100	± 500	μV	
dV_{OS}/dT	Offset drift, RTI	$T_A = -40^\circ\text{C to } +125^\circ\text{C}$		0.2	1	$\mu\text{V}/^\circ\text{C}$	
PSRR	Power-supply rejection ratio, RTI	$V_S = 2.7\text{ V to } 5.5\text{ V}$, $V_{SENSE} = 10\text{ mV}$		± 8	± 40	$\mu\text{V}/\text{V}$	
I_{IB}	Input bias current	$V_{SENSE} = 0\text{ mV}$, $V_{IN+} = 0\text{ V}$		0.1		μA	
		$V_{SENSE} = 0\text{ mV}$		80			
I_{IO}	Input offset current	$V_{SENSE} = 0\text{ mV}$		± 0.05		μA	
OUTPUT							
G	Gain	A1 devices		20		V/V	
		A2 devices		50			
		A3 devices		100			
		A4 devices		200			
E_G	Gain error	$V_{OUT} = 0.5\text{ V to } V_S - 0.5\text{ V}$, $T_A = -40^\circ\text{C to } +125^\circ\text{C}$		$\pm 0.1\%$	$\pm 1\%$		
	Gain error vs temperature	$T_A = -40^\circ\text{C to } +125^\circ\text{C}$		1.5	20	ppm/ $^\circ\text{C}$	
	Nonlinearity error	$V_{OUT} = 0.5\text{ V to } V_S - 0.5\text{ V}$		$\pm 0.01\%$			
	Maximum capacitive load	No sustained oscillation		1		nF	
VOLTAGE OUTPUT⁽³⁾							
V_{SP}	Swing to V_S power-supply rail ⁽⁴⁾	$R_L = 10\text{ k}\Omega$ to GND, $T_A = -40^\circ\text{C to } +125^\circ\text{C}$		$(V_S) - 0.02$	$(V_S) - 0.03$	V	
V_{SN}	Swing to GND ⁽⁴⁾	$R_L = 10\text{ k}\Omega$ to GND, $T_A = -40^\circ\text{C to } +125^\circ\text{C}$		$(V_{GND}) + 0.0005$	$(V_{GND}) + 0.005$	V	
FREQUENCY RESPONSE							
BW	Bandwidth	A1 devices, $C_{LOAD} = 10\text{ pF}$		350		kHz	
		A2 devices, $C_{LOAD} = 10\text{ pF}$		210			
		A3 devices, $C_{LOAD} = 10\text{ pF}$		150			
		A4 devices, $C_{LOAD} = 10\text{ pF}$		105			
SR	Slew rate			2		V/ μs	
NOISE, RTI							
	Voltage noise density			40		nV/ $\sqrt{\text{Hz}}$	
POWER SUPPLY							
I_Q	Quiescent current	INA180	$V_{SENSE} = 10\text{ mV}$		197	260	μA
			$V_{SENSE} = 10\text{ mV}$, $T_A = -40^\circ\text{C to } +125^\circ\text{C}$			300	
		INA2180	$V_{SENSE} = 10\text{ mV}$		355	500	
			$V_{SENSE} = 10\text{ mV}$, $T_A = -40^\circ\text{C to } +125^\circ\text{C}$			520	
		INA4180	$V_{SENSE} = 10\text{ mV}$		690	900	
			$V_{SENSE} = 10\text{ mV}$, $T_A = -40^\circ\text{C to } +125^\circ\text{C}$			1000	

(1) RTI = referred-to-input.

(2) Offset voltage is obtained by linear extrapolation to $V_{SENSE} = 0\text{ V}$ with $V_{SENSE} = 10\%$ to 90% of full-scale-range.

(3) See Figure 19.

(4) Swing specifications are tested with an overdriven input condition.

7.6 Typical Characteristics

at $T_A = 25^\circ\text{C}$, $V_S = 5\text{ V}$, and $V_{IN+} = 12\text{ V}$ (unless otherwise noted)

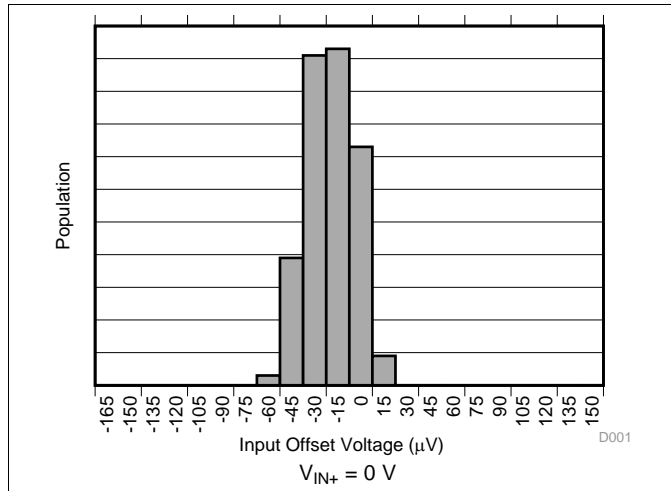

Figure 1. Input Offset Voltage Production Distribution A1

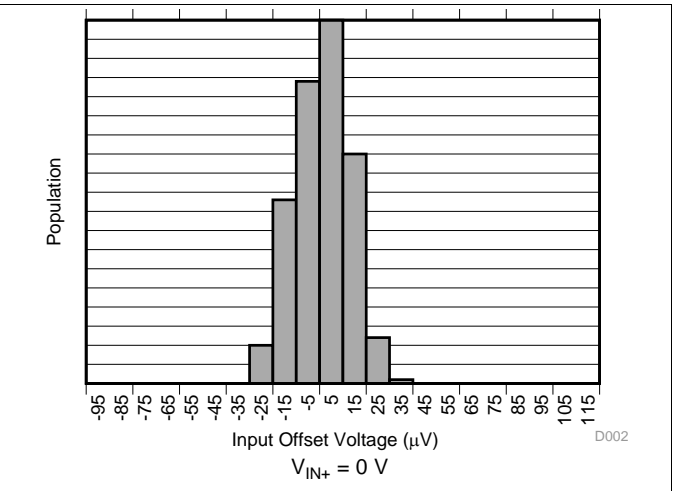

Figure 2. Input Offset Voltage Production Distribution A2

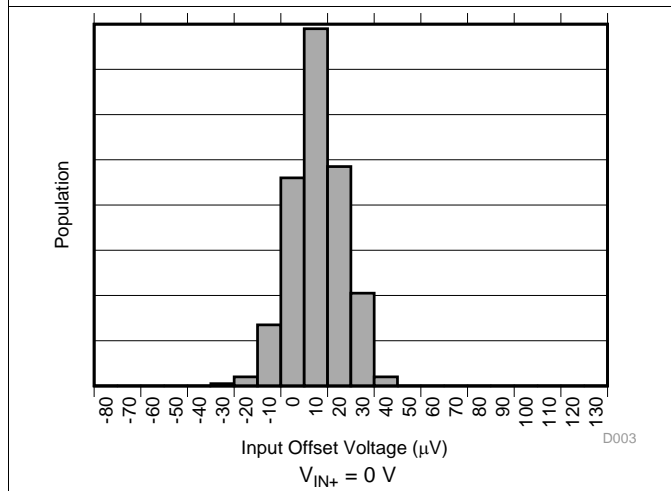

Figure 3. Input Offset Voltage Production Distribution A3

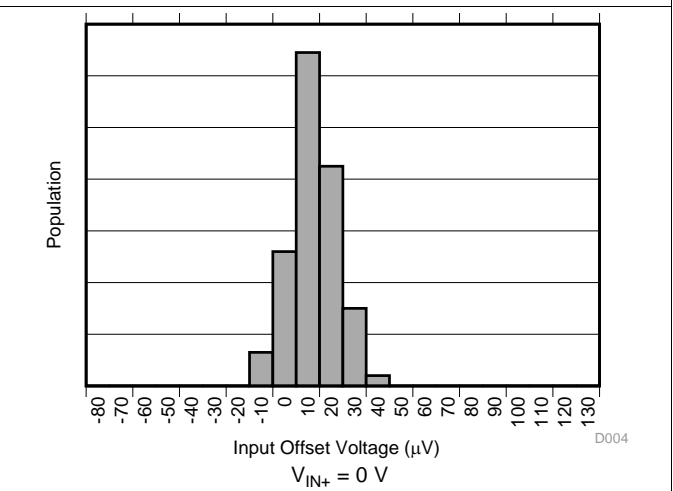

Figure 4. Input Offset Voltage Production Distribution A4

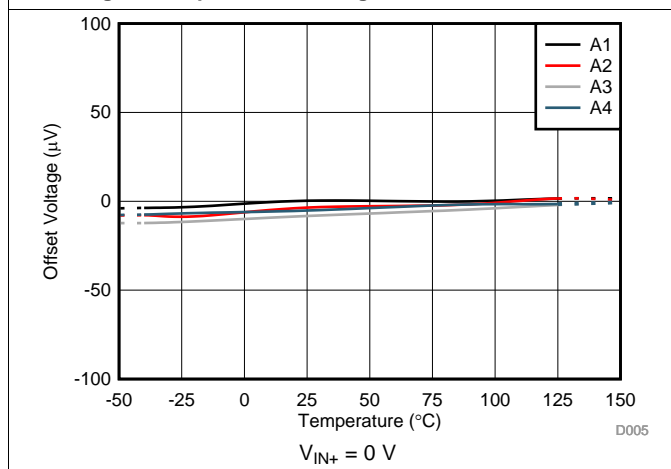

Figure 5. Offset Voltage vs Temperature

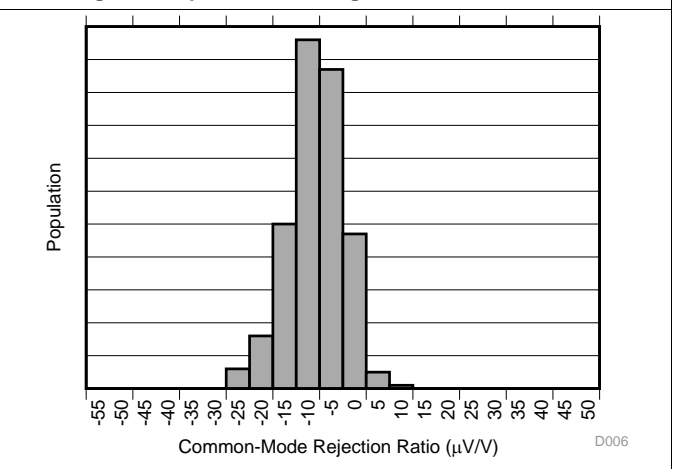
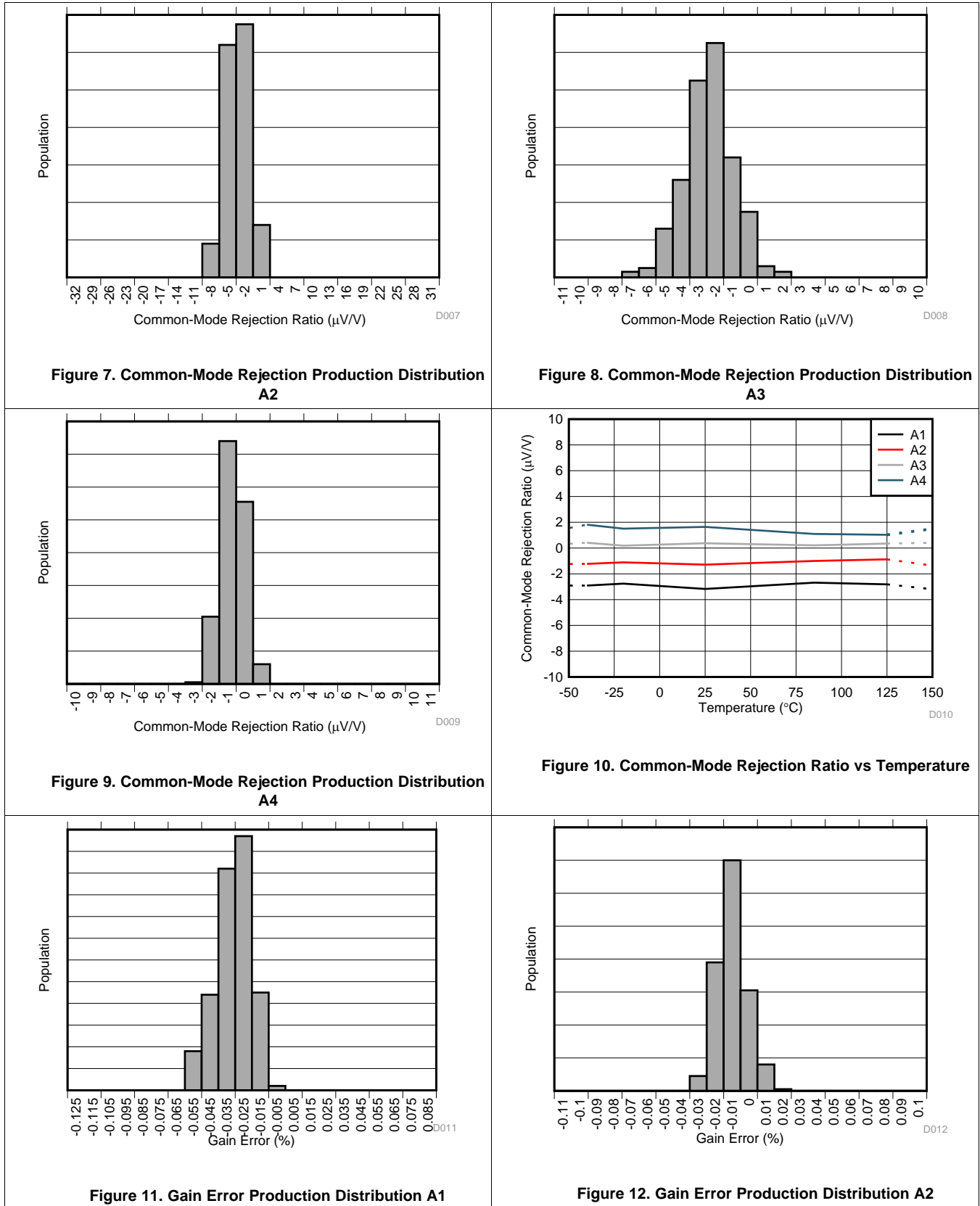

Figure 6. Common-Mode Rejection Ratio Production Distribution A1

Typical Characteristics (continued)

at $T_A = 25^\circ\text{C}$, $V_S = 5\text{ V}$, and $V_{IN+} = 12\text{ V}$ (unless otherwise noted)



Typical Characteristics (continued)

at $T_A = 25^\circ\text{C}$, $V_S = 5\text{ V}$, and $V_{IN+} = 12\text{ V}$ (unless otherwise noted)

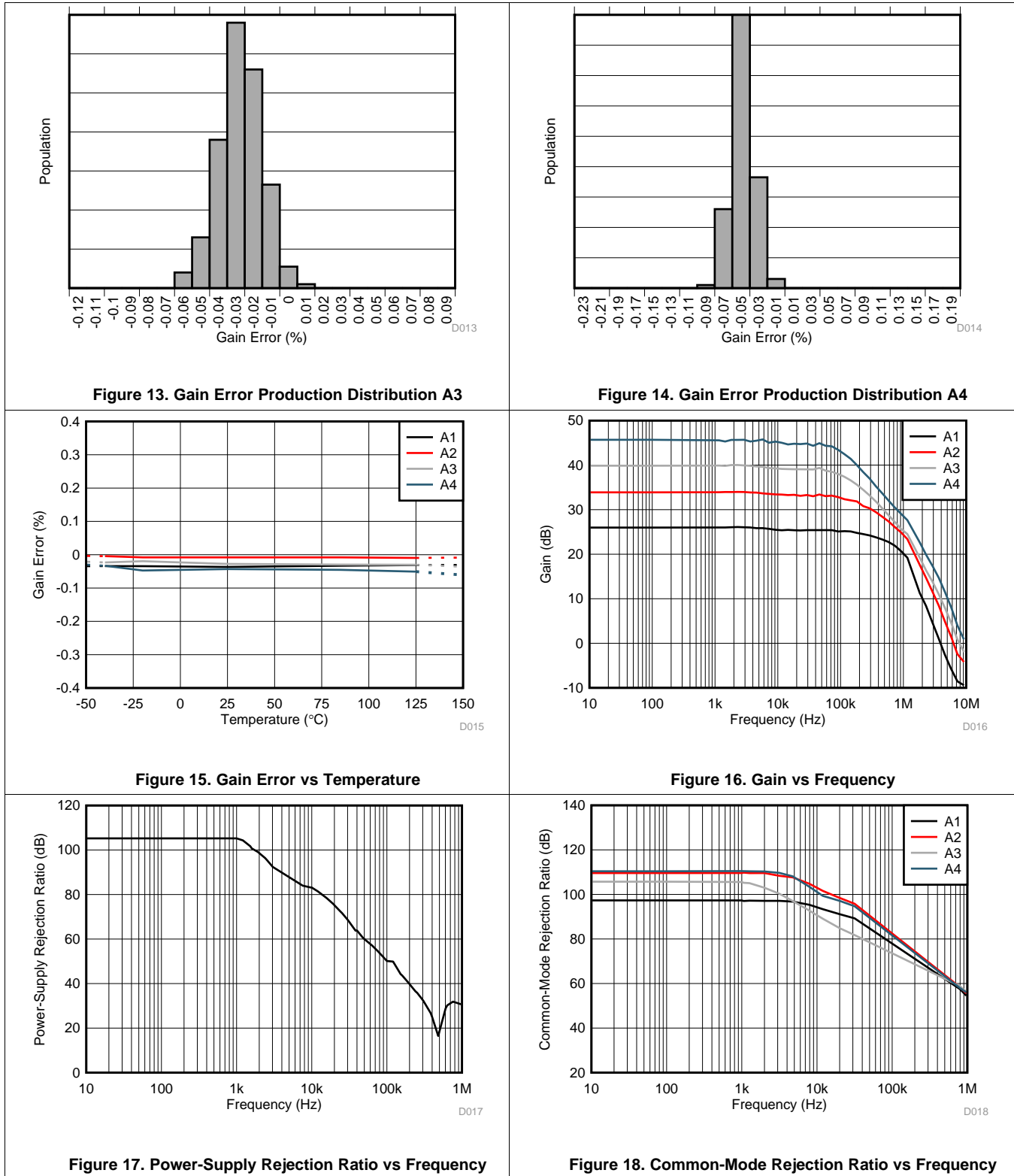

Typical Characteristics (continued)

at $T_A = 25^\circ\text{C}$, $V_S = 5\text{ V}$, and $V_{IN+} = 12\text{ V}$ (unless otherwise noted)

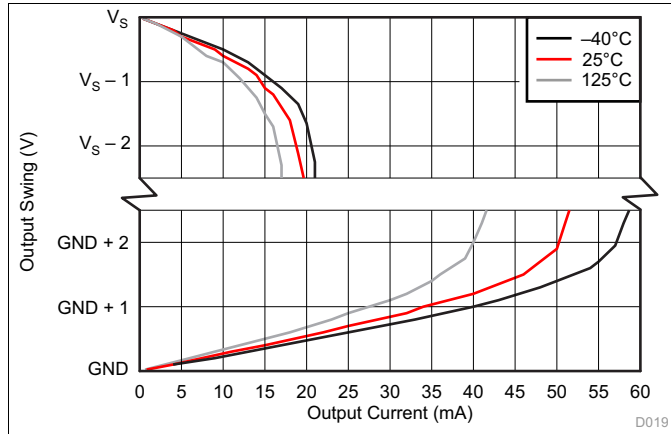

Figure 19. Output Voltage Swing vs Output Current

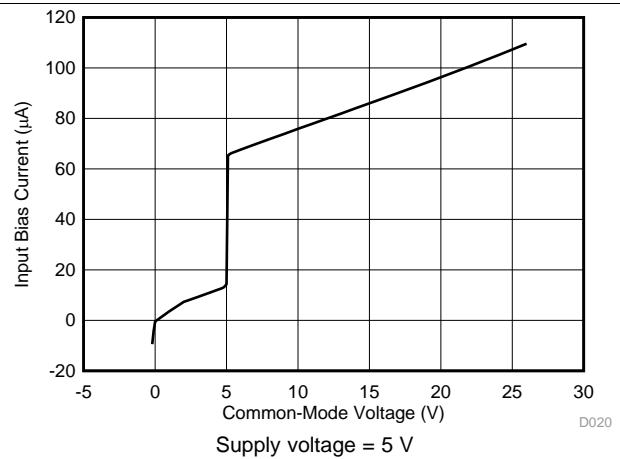

Figure 20. Input Bias Current vs Common-Mode Voltage

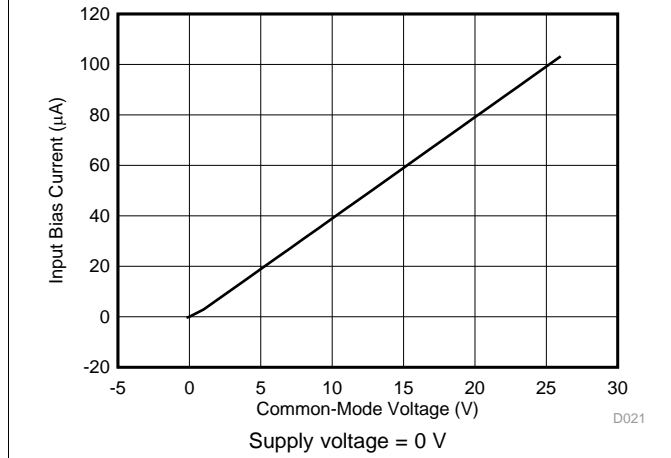

Figure 21. Input Bias Current vs Common-Mode Voltage (Both Inputs, Shutdown)

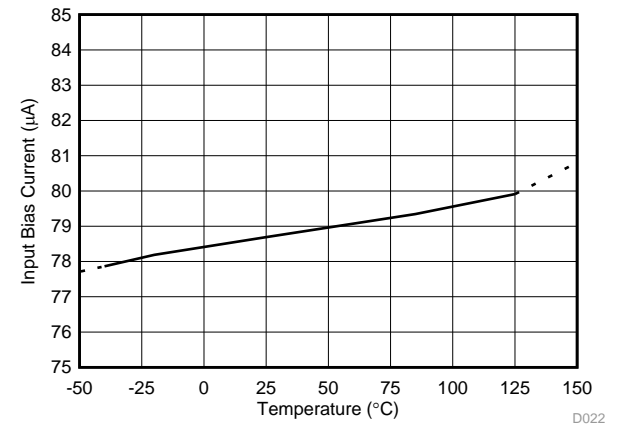

Figure 22. Input Bias Current vs Temperature

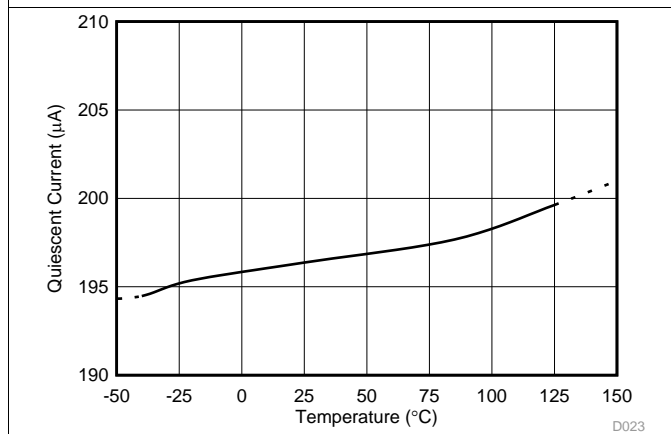

Figure 23. Quiescent Current vs Temperature (INA180)

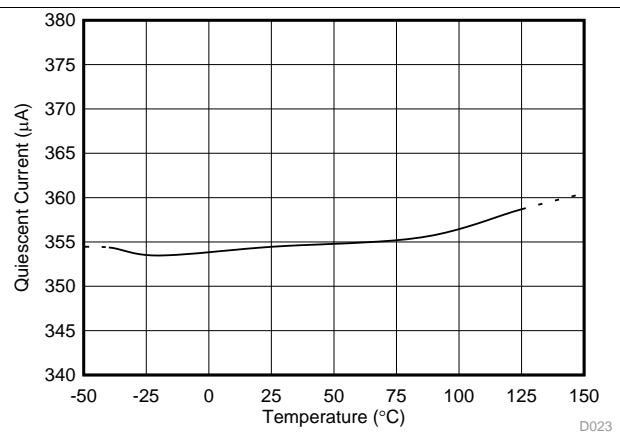

Figure 24. Quiescent Current vs Temperature (INA2180)

Typical Characteristics (continued)

at $T_A = 25^\circ\text{C}$, $V_S = 5\text{ V}$, and $V_{IN+} = 12\text{ V}$ (unless otherwise noted)

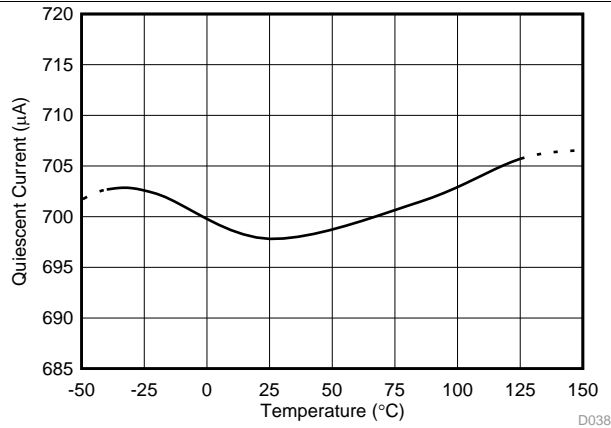

Figure 25. Quiescent Current vs Temperature (INA4180)

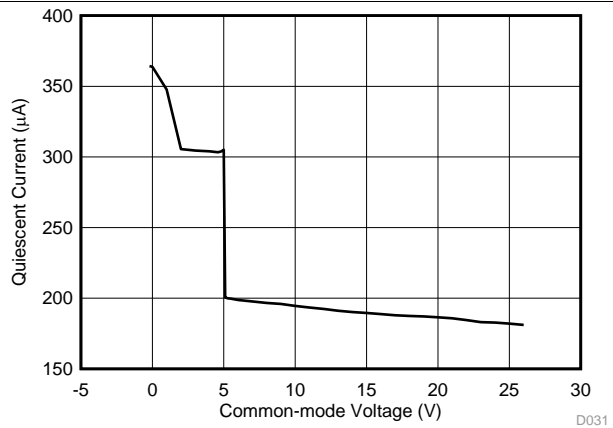

Figure 26. Quiescent Current vs Common-Mode Voltage (INA180)

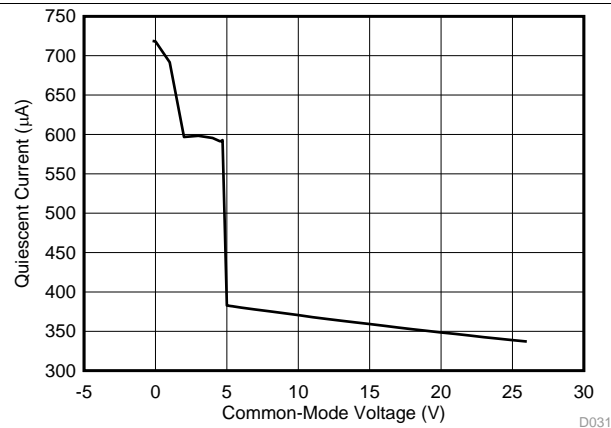

Figure 27. Quiescent Current vs Common-Mode Voltage for All Amplifiers (INA2180)

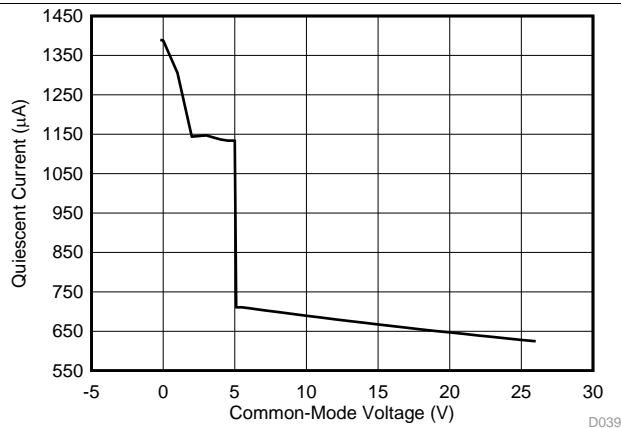

Figure 28. Quiescent Current vs Common-Mode Voltage for All Amplifiers (INA4180)

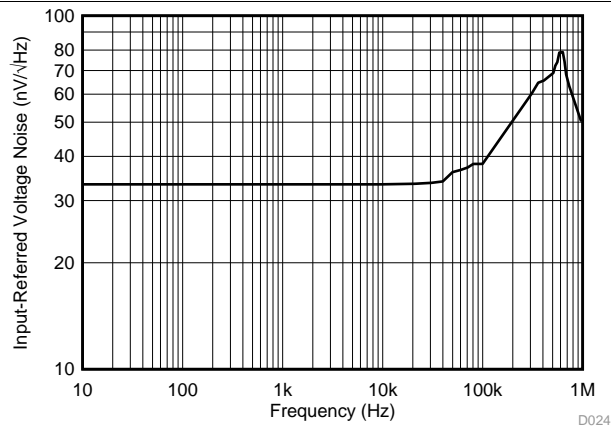

Figure 29. Input-Referred Voltage Noise vs Frequency (A3 Devices)

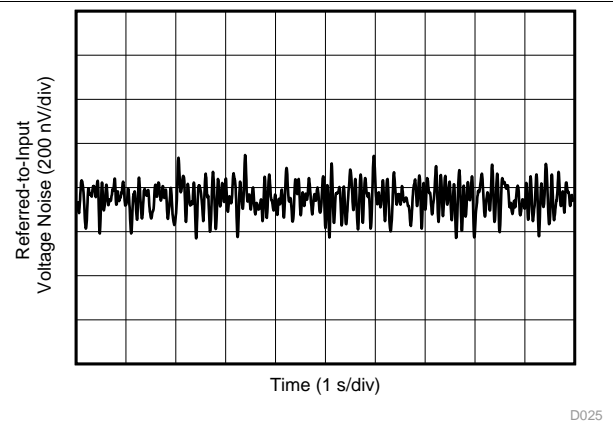
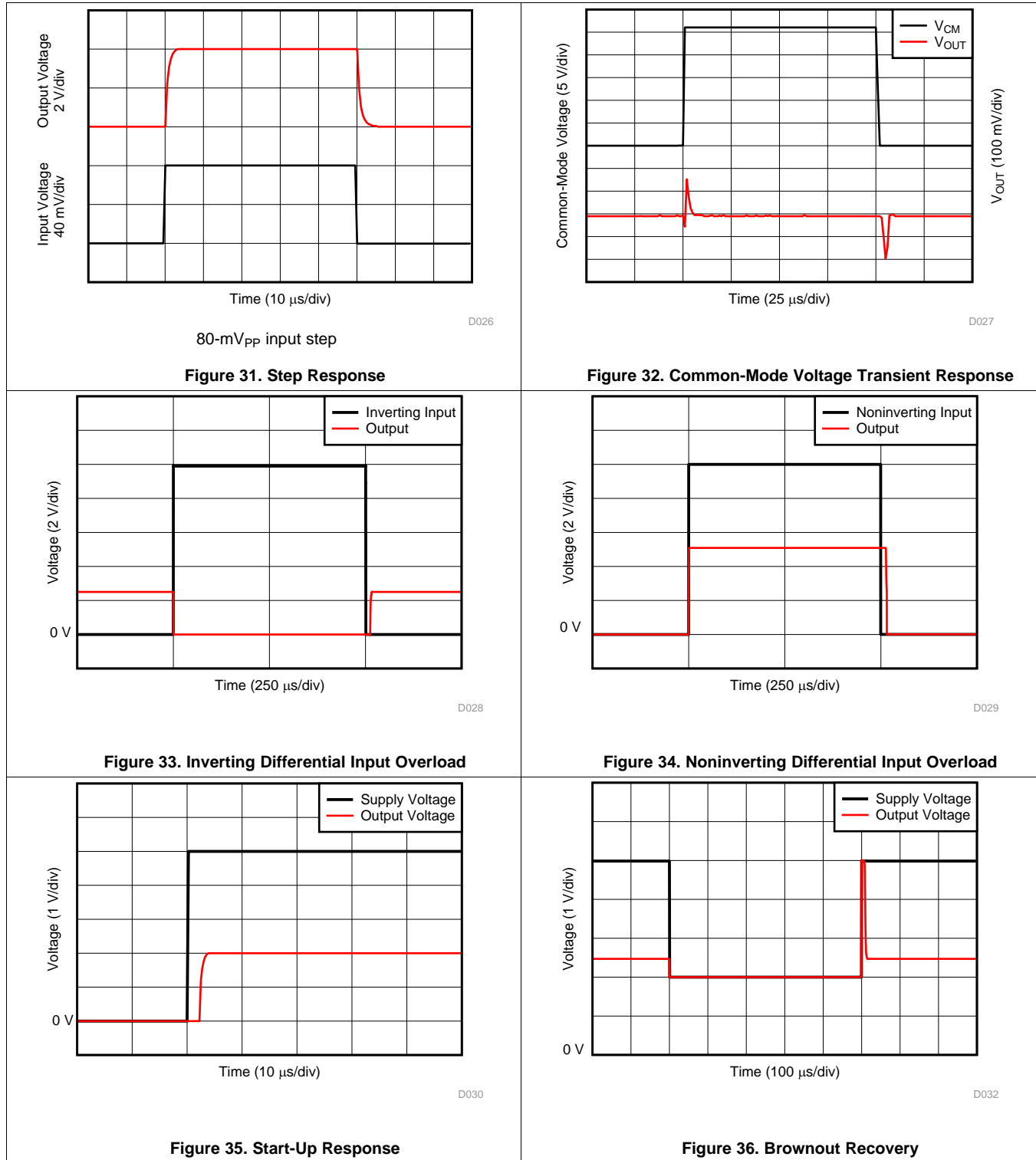

Figure 30. 0.1-Hz to 10-Hz Voltage Noise (Referred-to-Input)

Typical Characteristics (continued)

at $T_A = 25^\circ\text{C}$, $V_S = 5\text{ V}$, and $V_{IN+} = 12\text{ V}$ (unless otherwise noted)



Typical Characteristics (continued)

at $T_A = 25^\circ\text{C}$, $V_S = 5\text{ V}$, and $V_{IN+} = 12\text{ V}$ (unless otherwise noted)

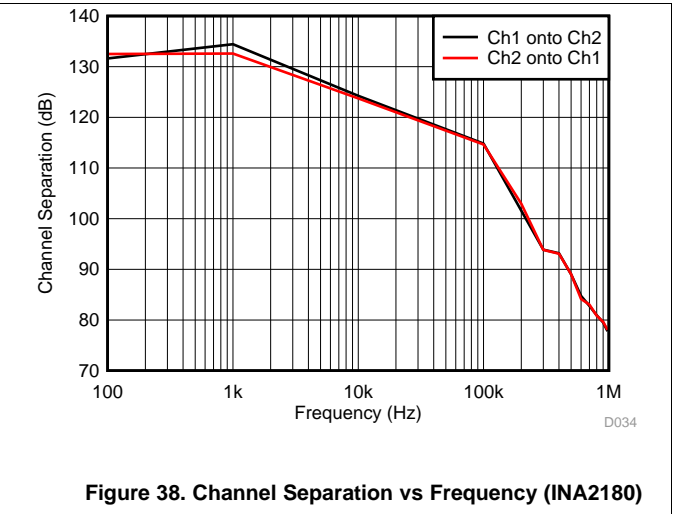
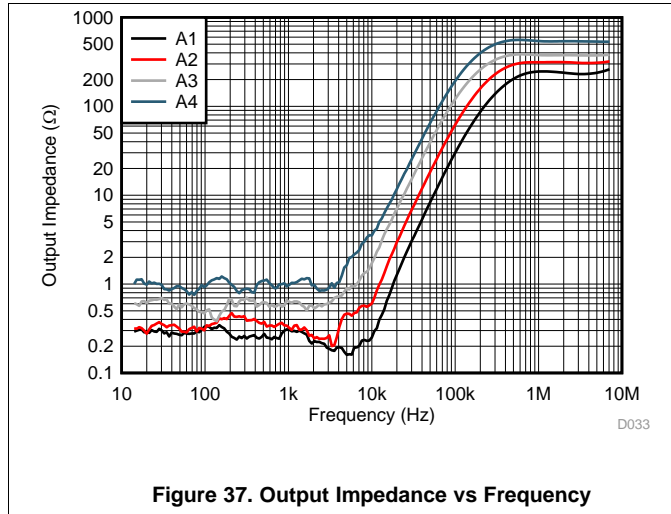

8 Detailed Description

8.1 Overview

The INA180, INA2180, and INA4180 (INAx180) are 26-V, common-mode, current-sensing amplifiers used in both low-side and high-side configurations. These specially-designed, current-sensing amplifiers accurately measures voltages developed across current-sensing resistors on common-mode voltages that far exceed the supply voltage powering the device. Current can be measured on input voltage rails as high as 26 V, and the devices can be powered from supply voltages as low as 2.7 V.

8.2 Functional Block Diagrams

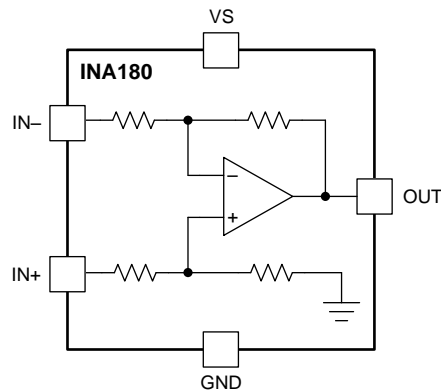

Copyright © 2017, Texas Instruments Incorporated

Figure 39. INA180 Functional Block Diagram

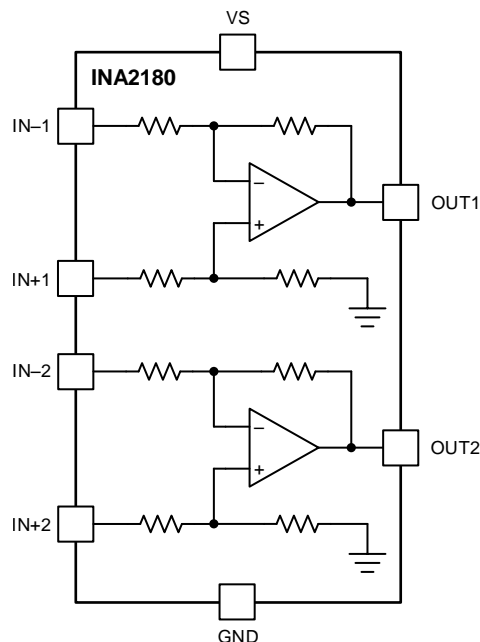

Copyright © 2017, Texas Instruments Incorporated

Figure 40. INA2180 Functional Block Diagram

Functional Block Diagrams (continued)

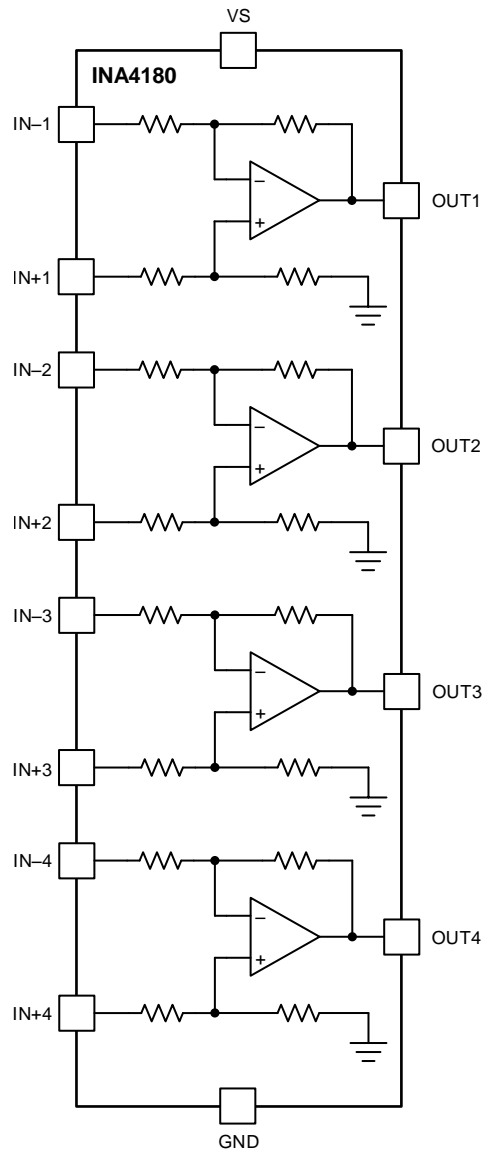

Copyright © 2017, Texas Instruments Incorporated

Figure 41. INA4180 Functional Block Diagram

8.3 Feature Description

8.3.1 High Bandwidth and Slew Rate

The INAx180 support small-signal bandwidths as high as 350 kHz, and large-signal slew rates of 2 V/ μ s. The ability to detect rapid changes in the sensed current, as well as the ability to quickly slew the output, make the INAx180 a good choice for applications that require a quick response to input current changes. One application that requires high bandwidth and slew rate is low-side motor control, where the ability to follow rapid changing current in the motor allows for more accurate control over a wider operating range. Another application that requires higher bandwidth and slew rates is system fault detection, where the INAx180 are used with an external comparator and a reference to quickly detect when the sensed current is out of range.

8.3.2 Wide Input Common-Mode Voltage Range

The INAx180 support input common-mode voltages from -0.2 V to $+26$ V. Because of the internal topology, the common-mode range is not restricted by the power-supply voltage (V_S) as long as V_S stays within the operational range of 2.7 V to 5.5 V. The ability to operate with common-mode voltages greater or less than V_S allow the INAx180 to be used in high-side, as well as low-side, current-sensing applications, as shown in [Figure 42](#).

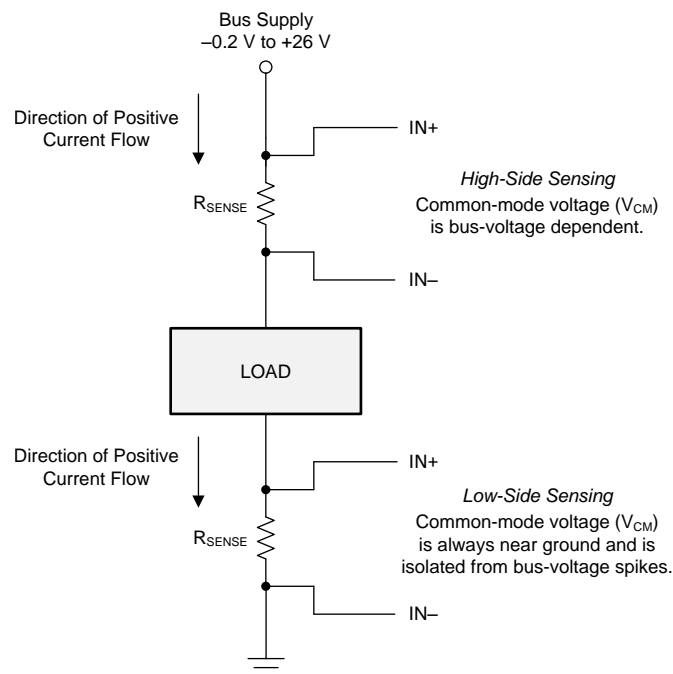

Figure 42. High-Side and Low-Side Sensing Connections

8.3.3 Precise Low-Side Current Sensing

When used in low-side current sensing applications the offset voltage of the INAx180 is within ± 150 μ V. The low offset performance of the INAx180 has several benefits. First, the low offset allows the device to be used in applications that must measure current over a wide dynamic range. In this case, the low offset improves the accuracy when the sensed currents are on the low end of the measurement range. Another advantage of low offset is the ability to sense lower voltage drop across the sense resistor accurately, thus allowing a lower-value shunt resistor. Lower-value shunt resistors reduce power loss in the current sense circuit, and help improve the power efficiency of the end application.

The gain error of the INAx180 is specified to be within 1% of the actual value. As the sensed voltage becomes much larger than the offset voltage, this voltage becomes the dominant source of error in the current sense measurement.

Feature Description (continued)

8.3.4 Rail-to-Rail Output Swing

The INAx180 allow linear current sensing operation with the output close to the supply rail and GND. The maximum specified output swing to the positive rail is 30 mV, and the maximum specified output swing to GND is only 5 mV. In order to compare the output swing of the INAx180 to an equivalent operational amplifier (op amp), the inputs are overdriven to approximate the open-loop condition specified in op amp data sheets. The current-sense amplifier is a closed-loop system; therefore, the output swing to GND can be limited by the product of the offset voltage and amplifier gain.

For devices that have positive offset voltages, the swing to GND is limited by the larger of either the offset voltage multiplied by the gain or the swing to GND specified in the [Electrical Characteristics](#) table.

For example, in an application where the INA180A4 (gain = 200 V/V) is used for low-side current sensing and the device has an offset of 40 μ V, the product of the device offset and gain results in a value of 8 mV, greater than the specified negative swing value. Therefore, the swing to GND for this example is 8 mV. If the same device has an offset of -40 μ V, then the calculated zero differential signal is -8 mV. In this case, the offset helps overdrive the swing in the negative direction, and swing performance is consistent with the value specified in the [Electrical Characteristics](#) table.

The offset voltage is a function of the common-mode voltage as determined by the CMRR specification; therefore, the offset voltage increases when higher common-mode voltages are present. The increase in offset voltage limits how low the output voltage can go during a zero-current condition when operating at higher common-mode voltages. [Figure 43](#) shows the typical limitation of the zero-current output voltage vs common-mode voltage for each gain option.

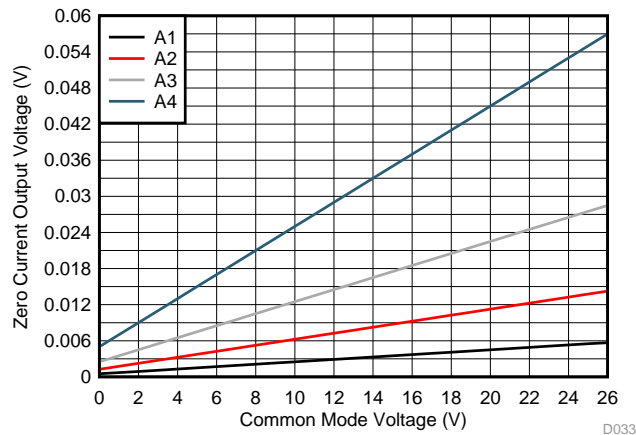

Figure 43. Zero-Current Output Voltage vs Common-Mode Voltage

8.4 Device Functional Modes

8.4.1 Normal Mode

The INAx180 is in normal operation when the following conditions are met:

- The power supply voltage (V_S) is between 2.7 V and 5.5 V.
- The common-mode voltage (V_{CM}) is within the specified range of -0.2 V to +26 V.
- The maximum differential input signal times gain is less than V_S minus the output voltage swing to V_S .
- The minimum differential input signal times gain is greater than the swing to GND (see the [Rail-to-Rail Output Swing](#) section).

During normal operation, the device produces an output voltage that is the *gained-up* representation of the difference voltage from $IN+$ to $IN-$.

Device Functional Modes (continued)

8.4.2 Input Differential Overload

If the differential input voltage ($V_{IN+} - V_{IN-}$) times gain exceeds the voltage swing specification, the INAx180 drive the output as close as possible to the positive supply, and does not provide accurate measurement of the differential input voltage. If this input overload occurs during normal circuit operation, then reduce the value of the shunt resistor or use a lower-gain version with the chosen sense resistor to avoid this mode of operation. If a differential overload occurs in a fault event, then the output of the INAx180 return to the expected value approximately 20 μ s after the fault condition is removed.

8.4.3 Shutdown Mode

Although the INAx180 do not have a shutdown pin, the low power consumption of the device allows the output of a logic gate or transistor switch to power the INAx180. This gate or switch turns on and off the INAx180 power-supply quiescent current.

However, in current shunt monitoring applications, there is also a concern for how much current is drained from the shunt circuit in shutdown conditions. Evaluating this current drain involves considering the simplified schematic of the INAx180 in shutdown mode, as shown in Figure 44.

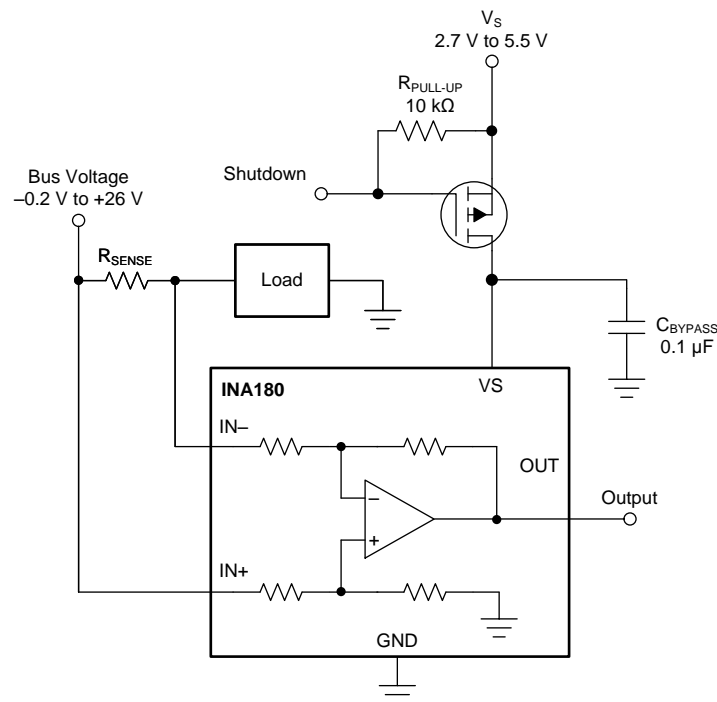

Copyright © 2017, Texas Instruments Incorporated

Figure 44. Basic Circuit to Shut Down the INAx180

There is typically more than 500 k Ω of impedance (from the combination of 500-k Ω feedback and input gain set resistors) from each input of the INAx180 to the OUT pin and to the GND pin. The amount of current flowing through these pins depends on the voltage at the connection.

Regarding the 500-k Ω path to the output pin, the output stage of a disabled INAx180 does constitute a good path to ground. Consequently, this current is directly proportional to a shunt common-mode voltage present across a 500-k Ω resistor.

As a final note, as long as the shunt common-mode voltage is greater than V_S when the device is powered up, there is an additional and well-matched 55- μ A typical current that flows in each of the inputs. If less than V_S , the common-mode input currents are negligible, and the only current effects are the result of the 500-k Ω resistors.

9 Application and Implementation

NOTE

Information in the following applications sections is not part of the TI component specification, and TI does not warrant its accuracy or completeness. TI's customers are responsible for determining suitability of components for their purposes. Customers should validate and test their design implementation to confirm system functionality.

9.1 Application Information

The INAx180 amplify the voltage developed across a current-sensing resistor as current flows through the resistor to the load or ground.

9.1.1 Basic Connections

Figure 45 shows the basic connections of the INA180. Connect the input pins (IN+ and IN–) as closely as possible to the shunt resistor to minimize any resistance in series with the shunt resistor.

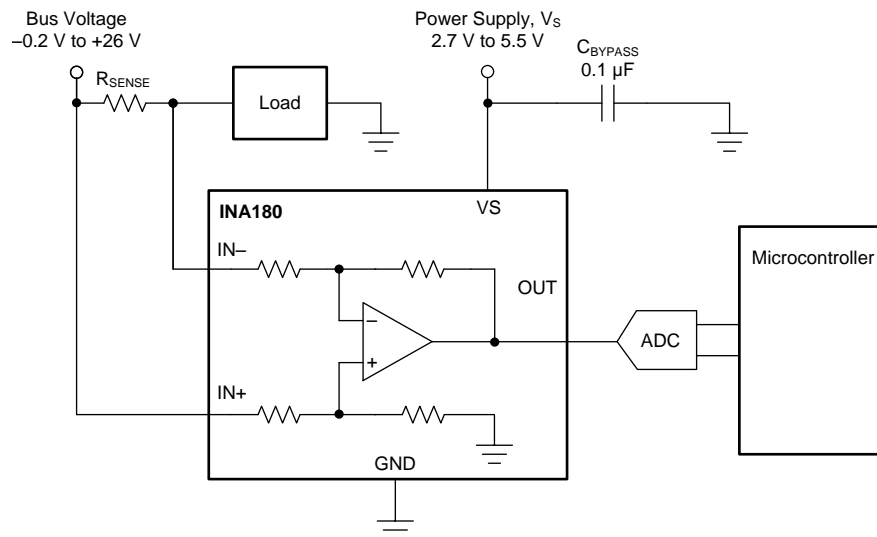

Copyright © 2017, Texas Instruments Incorporated

NOTE: For best measurement accuracy, connect analog-to-digital converter (ADC) reference or microcontroller ground as closely as possible to the INAx180 GND pin, and add an RC filter between the output of the INAx180 and the ADC. See [Closed-Loop Analysis of Load-Induced Amplifier Stability Issues Using Z_{OUT}](#) for more details.

Figure 45. Basic Connections for the INA180

A power-supply bypass capacitor of at least 0.1 μF is required for proper operation. Applications with noisy or high-impedance power supplies may require additional decoupling capacitors to reject power-supply noise. Connect bypass capacitors close to the device pins.

Application Information (continued)

9.1.2 R_{SENSE} and Device Gain Selection

The accuracy of the INAx180 is maximized by choosing the current-sense resistor to be as large as possible. A large sense resistor maximizes the differential input signal for a given amount of current flow and reduces the error contribution of the offset voltage. However, there are practical limits as to how large the current-sense resistor can be in a given application. The INAx180 have a typical input bias currents of 80 μA for each input when operated at a 12-V common-mode voltage input. When large current-sense resistors are used, these bias currents cause increased offset error and reduced common-mode rejection. Therefore, using current-sense resistors larger than a few ohms is generally not recommended for applications that require current-monitoring accuracy. A second common restriction on the value of the current-sense resistor is the maximum allowable power dissipation that is budgeted for the resistor. [Equation 1](#) gives the maximum value for the current sense resistor for a given power dissipation budget:

$$R_{\text{SENSE}} < \frac{PD_{\text{MAX}}}{I_{\text{MAX}}^2}$$

where:

- PD_{MAX} is the maximum allowable power dissipation in R_{SENSE}.
 - I_{MAX} is the maximum current that will flow through R_{SENSE}.
- (1)

An additional limitation on the size of the current-sense resistor and device gain is due to the power-supply voltage, V_S, and device swing to rail limitations. In order to make sure that the current-sense signal is properly passed to the output, both positive and negative output swing limitations must be examined. [Equation 2](#) provides the maximum values of R_{SENSE} and GAIN to keep the device from hitting the positive swing limitation.

$$I_{\text{MAX}} \times R_{\text{SENSE}} \times \text{GAIN} < V_{\text{SP}}$$

where:

- I_{MAX} is the maximum current that will flow through R_{SENSE}.
 - GAIN is the gain of the current sense-amplifier.
 - V_{SP} is the positive output swing as specified in the data sheet.
- (2)

To avoid positive output swing limitations when selecting the value of R_{SENSE}, there is always a trade-off between the value of the sense resistor and the gain of the device under consideration. If the sense resistor selected for the maximum power dissipation is too large, then it is possible to select a lower-gain device in order to avoid positive swing limitations.

The negative swing limitation places a limit on how small of a sense resistor can be used in a given application. [Equation 3](#) provides the limit on the minimum size of the sense resistor.

$$I_{\text{MIN}} \times R_{\text{SENSE}} \times \text{GAIN} > V_{\text{SN}}$$

where:

- I_{MIN} is the minimum current that will flow through R_{SENSE}.
 - GAIN is the gain of the current sense amplifier.
 - V_{SN} is the negative output swing of the device (see [Rail-to-Rail Output Swing](#)).
- (3)

Application Information (continued)

9.1.3 Signal Filtering

Provided that the INAx180 output is connected to a high impedance input, the best location to filter is at the device output using a simple RC network from OUT to GND. Filtering at the output attenuates high-frequency disturbances in the common-mode voltage, differential input signal, and INAx180 power-supply voltage. If filtering at the output is not possible, or filtering of only the differential input signal is required, it is possible to apply a filter at the input pins of the device. [Figure 46](#) provides an example of how a filter can be used on the input pins of the device.

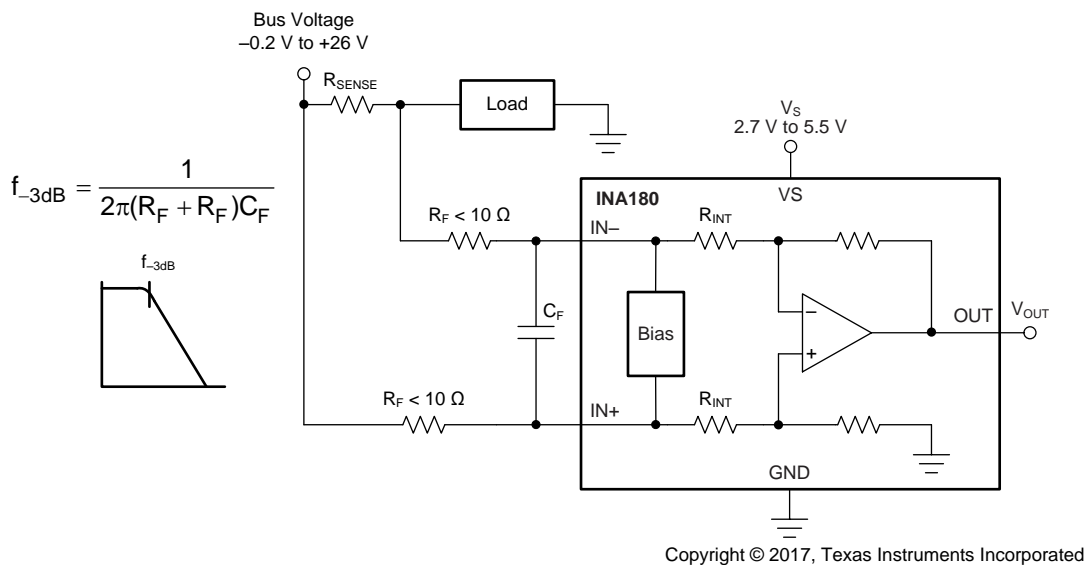

Copyright © 2017, Texas Instruments Incorporated

Figure 46. Filter at Input Pins

The addition of external series resistance creates an additional error in the measurement; therefore, the value of these series resistors must be kept to 10 Ω (or less, if possible) to reduce impact to accuracy. The internal bias network shown in [Figure 46](#) present at the input pins creates a mismatch in input bias currents when a differential voltage is applied between the input pins. If additional external series filter resistors are added to the circuit, the mismatch in bias currents results in a mismatch of voltage drops across the filter resistors. This mismatch creates a differential error voltage that subtracts from the voltage developed across the shunt resistor. This error results in a voltage at the device input pins that is different than the voltage developed across the shunt resistor. Without the additional series resistance, the mismatch in input bias currents has little effect on device operation. The amount of error these external filter resistors add to the measurement can be calculated using [Equation 5](#), where the gain error factor is calculated using [Equation 4](#).

The amount of variance in the differential voltage present at the device input relative to the voltage developed at the shunt resistor is based both on the external series resistance (R_F) value as well as internal input resistor R_{INT} , as shown in [Figure 46](#). The reduction of the shunt voltage reaching the device input pins appears as a gain error when comparing the output voltage relative to the voltage across the shunt resistor. A factor can be calculated to determine the amount of gain error that is introduced by the addition of external series resistance. Calculate the expected deviation from the shunt voltage to what is measured at the device input pins is given using [Equation 4](#):

$$\text{Gain Error Factor} = \frac{1250 \times R_{INT}}{(1250 \times R_F) + (1250 \times R_{INT}) + (R_F \times R_{INT})}$$

where:

- R_{INT} is the internal input resistor.
- R_F is the external series resistance.

(4)

Application Information (continued)

With the adjustment factor from [Equation 4](#), including the device internal input resistance, this factor varies with each gain version, as shown in [Table 1](#). Each individual device gain error factor is shown in [Table 2](#).

Table 1. Input Resistance

PRODUCT	GAIN	R _{INT} (kΩ)
INAx180A1	20	25
INAx180A2	50	10
INAx180A3	100	5
INAx180A4	200	2.5

Table 2. Device Gain Error Factor

PRODUCT	SIMPLIFIED GAIN ERROR FACTOR
INAx180A1	$\frac{25000}{(21 \times R_F) + 25000}$
INAx180A2	$\frac{10000}{(9 \times R_F) + 10000}$
INAx180A3	$\frac{1000}{R_F + 1000}$
INAx180A4	$\frac{2500}{(3 \times R_F) + 2500}$

The gain error that can be expected from the addition of the external series resistors can then be calculated based on [Equation 5](#):

$$\text{Gain Error (\%)} = 100 - (100 \times \text{Gain Error Factor}) \quad (5)$$

For example, using an INA180A2 and the corresponding gain error equation from [Table 2](#), a series resistance of 10 Ω results in a gain error factor of 0.991. The corresponding gain error is then calculated using [Equation 5](#), resulting in an additional gain error of approximately 0.89% solely because of the external 10-Ω series resistors.

9.2 Typical Application

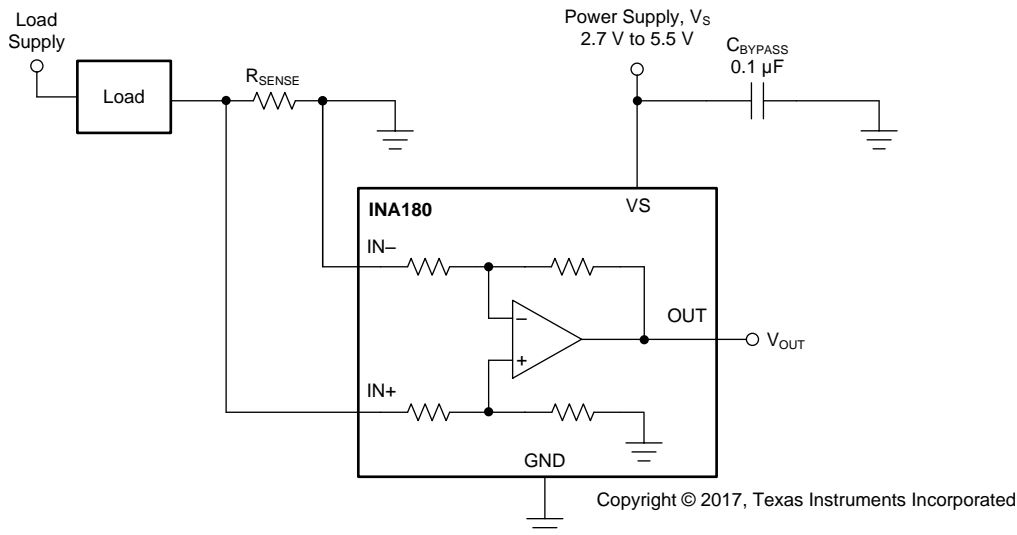

Figure 47. Low-Side Sensing

9.2.1 Design Requirements

The design requirements for the circuit shown in [Figure 47](#), are listed in [Table 3](#)

Table 3. Design Parameters

DESIGN PARAMETER	EXAMPLE VALUE
Power-supply voltage, V_S	5 V
Low-side current sensing	$V_{CM} = 0$ V
R_{SENSE} power loss	< 900 mW
Maximum sense current, I_{MAX}	40 A
Current sensing error	Less than 1.5% at maximum current, $T_J = 25^\circ\text{C}$
Small-signal bandwidth	> 80 kHz

9.2.2 Detailed Design Procedure

The maximum value of the current sense resistor is calculated based on the maximum power loss requirement. By applying [Equation 1](#), the maximum value of the current-sense resistor is calculated to be 0.563 m Ω . This is the maximum value for sense resistor R_{SENSE} ; therefore, select R_{SENSE} to be 0.5 m Ω because it is the closest standard resistor value that meets the power-loss requirement.

The next step is to select the appropriate gain and reduce R_{SENSE} , if needed, to keep the output signal swing within the V_S range. Using [Equation 2](#), and given that $I_{MAX} = 40$ A and $R_{SENSE} = 0.5$ m Ω , the maximum current-sense gain calculated to avoid the positive swing-to-rail limitations on the output is 248.5. To maximize the output signal range, the INA180A4 (gain = 200) device is selected for this application.

To calculate the accuracy at peak current, the two factors that must be determined are the gain error and the offset error. The gain error of the INAx180 is specified to be a maximum of 1%. The error due to the offset is constant, and is specified to be 125 μV (maximum) for the conditions where $V_{CM} = 0$ V and $V_S = 5$ V. Using [Equation 6](#), the percentage error contribution of the offset voltage is calculated to be 0.75%, with total offset error = 150 μV , $R_{SENSE} = 0.5$ m Ω , and $I_{SENSE} = 40$ A.

$$\text{Total Offset Error (\%)} = \frac{\text{Total Offset Error (V)}}{I_{SENSE} \times R_{SENSE}} \times 100\% \quad (6)$$

One method of calculating the total error is to add the gain error to the percentage contribution of the offset error. However, in this case, the gain error and the offset error do not have an influence or correlation to each other. A more statistically accurate method of calculating the total error is to use the RSS sum of the errors, as shown in Equation 7:

$$\text{Total Error (\%)} = \sqrt{\text{Total Gain Error (\%)}^2 + \text{Total Offset Error (\%)}^2} \tag{7}$$

After applying Equation 7, the total current sense error at maximum current is calculated to be 1.25%, and that is less than the design example requirement of 1.5%.

The INA180A4 (gain = 200) also has a bandwidth of 105 kHz that meets the small-signal bandwidth requirement of 80 kHz. If higher bandwidth is required, lower-gain devices can be used at the expense of either reduced output voltage range or an increased value of R_{SENSE}.

9.2.3 Application Curve

Figure 48 shows an example output response of a unidirectional configuration. The device output swing is limited by ground; therefore, the output is biased to this zero output level. The output rises above ground for positive differential input signals, but cannot fall below ground for negative differential input signals.

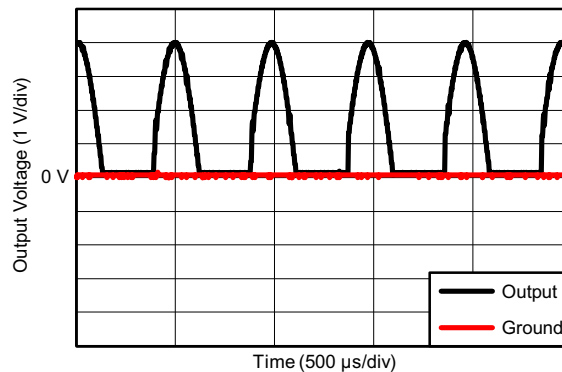

Figure 48. Output Response

10 Power Supply Recommendations

The input circuitry of the INAx180 accurately measures beyond the power-supply voltage, V_S . For example, V_S can be 5 V, whereas the bus supply voltage at IN+ and IN– can be as high as 26 V. However, the output voltage range of the OUT pin is limited by the voltages on the VS pin. The INAx180 also withstand the full differential input signal range up to 26 V at the IN+ and IN– input pins, regardless of whether or not the device has power applied at the VS pin.

10.1 Common-Mode Transients Greater Than 26 V

With a small amount of additional circuitry, the INAx180 can be used in circuits subject to transients higher than 26 V, such as automotive applications. Use only Zener diodes or Zener-type transient absorbers (sometimes referred to as *transzorb*s)—any other type of transient absorber has an unacceptable time delay. Start by adding a pair of resistors as a working impedance for the Zener diode, as shown [Figure 49](#). Keep these resistors as small as possible; most often, around 10 Ω . Larger values can be used with an effect on gain that is discussed in the [Signal Filtering](#) section. This circuit limits only short-term transients; therefore, many applications are satisfied with a 10- Ω resistor along with conventional Zener diodes of the lowest acceptable power rating. This combination uses the least amount of board space. These diodes can be found in packages as small as SOT-523 or SOD-523.

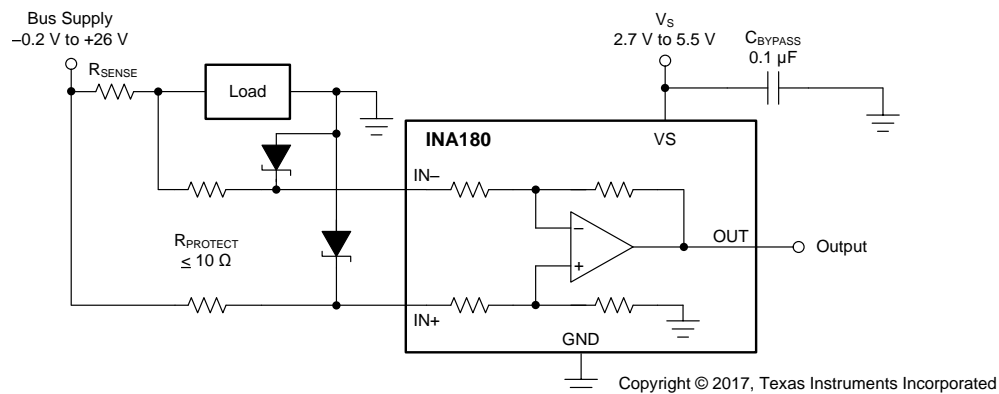

Figure 49. Transient Protection Using Dual Zener Diodes

In the event that low-power Zener diodes do not have sufficient transient absorption capability, a higher-power transzorb must be used. The most package-efficient solution involves using a single transzorb and back-to-back diodes between the device inputs, as shown in [Figure 50](#). The most space-efficient solutions are dual, series-connected diodes in a single SOT-523 or SOD-523 package. In either of the examples shown in [Figure 49](#) and [Figure 50](#), the total board area required by the INAx180 with all protective components is less than that of an SO-8 package, and only slightly greater than that of an MSOP-8 package.

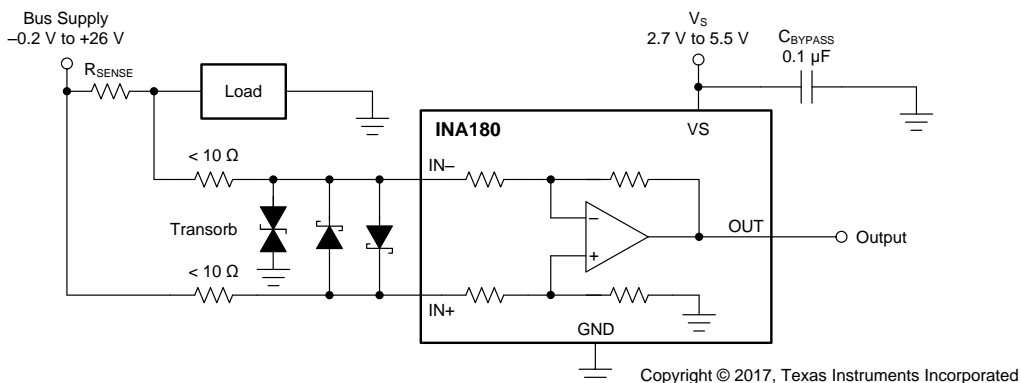

Figure 50. Transient Protection Using a Single Transzorb and Input Clamps

For a reference design example, see [Current Shunt Monitor With Transient Robustness Reference Design](#).

11 Layout

11.1 Layout Guidelines

- Connect the input pins to the sensing resistor using a Kelvin or 4-wire connection. This connection technique makes sure that only the current-sensing resistor impedance is detected between the input pins. Poor routing of the current-sensing resistor commonly results in additional resistance present between the input pins. Given the very low ohmic value of the current resistor, any additional high-current carrying impedance can cause significant measurement errors.
- Place the power-supply bypass capacitor as close as possible to the device power supply and ground pins. The recommended value of this bypass capacitor is 0.1 μF . Additional decoupling capacitance can be added to compensate for noisy or high-impedance power supplies.
- When routing the connections from the current sense resistor to the device, keep the trace lengths as close as possible in order to minimize any impedance mismatch.

11.2 Layout Examples

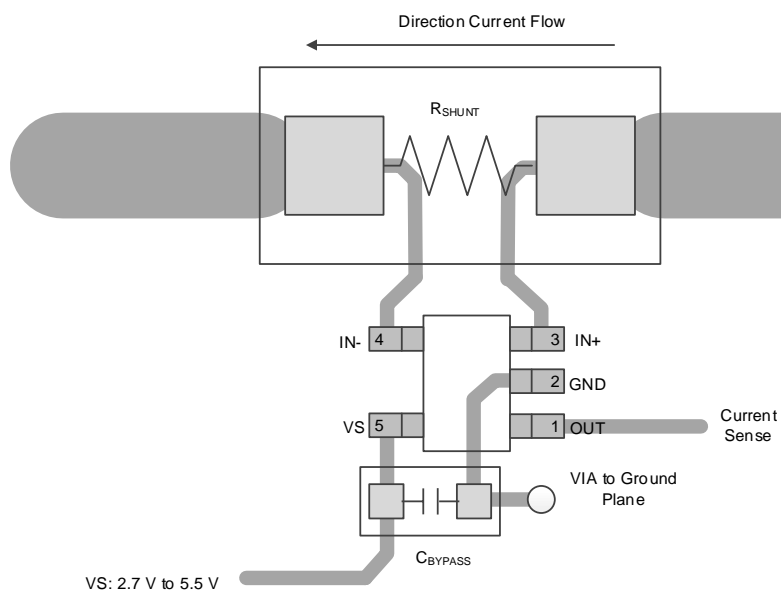

Figure 51. Single-Channel Recommended Layout

Layout Examples (continued)

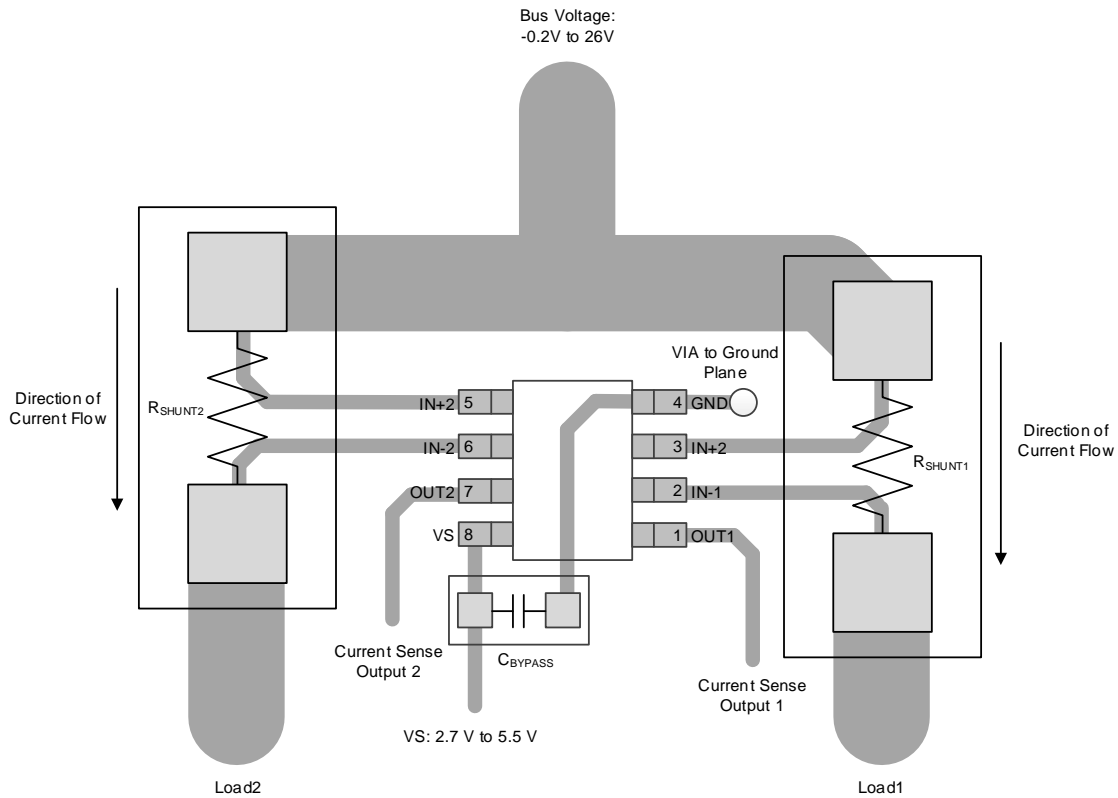

Figure 52. Dual-Channel Recommended Layout

Layout Examples (continued)

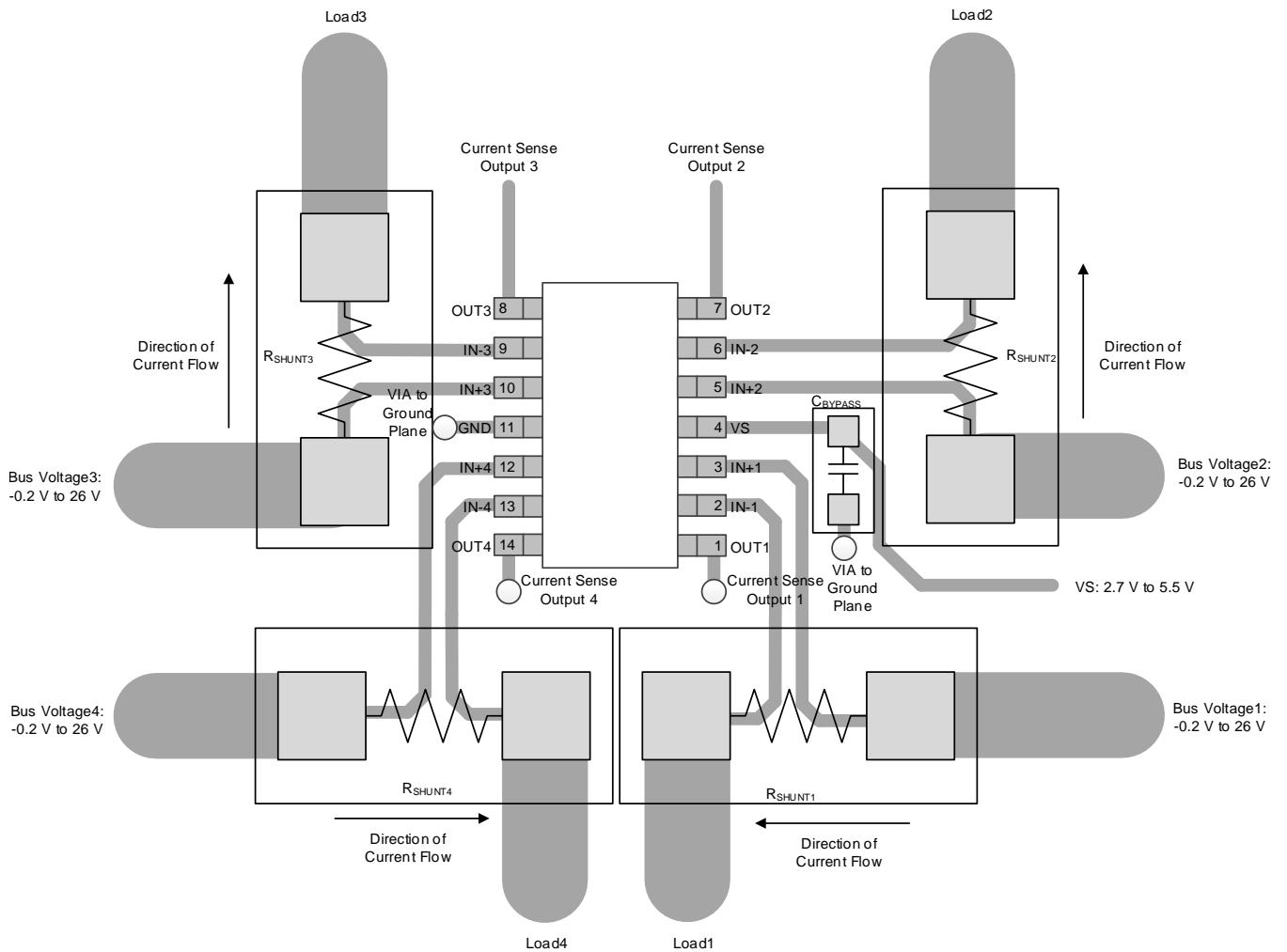

Figure 53. Quad-Channel Recommended Layout

12 Device and Documentation Support

12.1 Documentation Support

12.1.1 Related Documentation

For related documentation see the following:

- [INA180-181EVM User's Guide](#)
- [INA2180-2181EVM User's Guide](#)
- [INA4180-4181EVM User's Guide](#)

12.2 Related Links

lists quick access links. Categories include technical documents, support and community resources, tools and software, and quick access to order now.

Table 4. Related Links

PARTS	PRODUCT FOLDER	ORDER NOW	TECHNICAL DOCUMENTS	TOOLS & SOFTWARE	SUPPORT & COMMUNITY
INA180	Click here	Click here	Click here	Click here	Click here
INA2180	Click here	Click here	Click here	Click here	Click here
INA4180	Click here	Click here	Click here	Click here	Click here

12.3 Receiving Notification of Documentation Updates

To receive notification of documentation updates, navigate to the device product folder on ti.com. In the upper right corner, click on *Alert me* to register and receive a weekly digest of any product information that has changed. For change details, review the revision history included in any revised document.

12.4 Community Resources

The following links connect to TI community resources. Linked contents are provided "AS IS" by the respective contributors. They do not constitute TI specifications and do not necessarily reflect TI's views; see TI's [Terms of Use](#).

TI E2E™ Online Community *TI's Engineer-to-Engineer (E2E) Community*. Created to foster collaboration among engineers. At e2e.ti.com, you can ask questions, share knowledge, explore ideas and help solve problems with fellow engineers.

Design Support *TI's Design Support* Quickly find helpful E2E forums along with design support tools and contact information for technical support.

12.5 Trademarks

E2E is a trademark of Texas Instruments.
All other trademarks are the property of their respective owners.

12.6 Electrostatic Discharge Caution



This integrated circuit can be damaged by ESD. Texas Instruments recommends that all integrated circuits be handled with appropriate precautions. Failure to observe proper handling and installation procedures can cause damage.

ESD damage can range from subtle performance degradation to complete device failure. Precision integrated circuits may be more susceptible to damage because very small parametric changes could cause the device not to meet its published specifications.

12.7 Glossary

SLYZ022 — *TI Glossary*.

This glossary lists and explains terms, acronyms, and definitions.

13 Mechanical, Packaging, and Orderable Information

The following pages include mechanical, packaging, and orderable information. This information is the most current data available for the designated devices. This data is subject to change without notice and revision of this document. For browser-based versions of this data sheet, refer to the left-hand navigation.

PACKAGING INFORMATION

Orderable Device	Status (1)	Package Type	Package Drawing	Pins	Package Qty	Eco Plan (2)	Lead/Ball Finish (6)	MSL Peak Temp (3)	Op Temp (°C)	Device Marking (4/5)	Samples
INA180A1IDBVR	ACTIVE	SOT-23	DBV	5	3000	Green (RoHS & no Sb/Br)	CU SN	Level-1-260C-UNLIM	-40 to 125	18ID	Samples
INA180A1IDBVT	ACTIVE	SOT-23	DBV	5	250	Green (RoHS & no Sb/Br)	CU SN	Level-1-260C-UNLIM	-40 to 125	18ID	Samples
INA180A2IDBVR	ACTIVE	SOT-23	DBV	5	3000	Green (RoHS & no Sb/Br)	CU SN	Level-1-260C-UNLIM	-40 to 125	1A8D	Samples
INA180A2IDBVT	ACTIVE	SOT-23	DBV	5	250	Green (RoHS & no Sb/Br)	CU SN	Level-1-260C-UNLIM	-40 to 125	1A8D	Samples
INA180A3IDBVR	ACTIVE	SOT-23	DBV	5	3000	Green (RoHS & no Sb/Br)	CU SN	Level-1-260C-UNLIM	-40 to 125	1A9D	Samples
INA180A3IDBVT	ACTIVE	SOT-23	DBV	5	250	Green (RoHS & no Sb/Br)	CU SN	Level-1-260C-UNLIM	-40 to 125	1A9D	Samples
INA180A4IDBVR	ACTIVE	SOT-23	DBV	5	3000	Green (RoHS & no Sb/Br)	CU SN	Level-1-260C-UNLIM	-40 to 125	1AAD	Samples
INA180A4IDBVT	ACTIVE	SOT-23	DBV	5	250	Green (RoHS & no Sb/Br)	CU SN	Level-1-260C-UNLIM	-40 to 125	1AAD	Samples
INA180B1IDBVR	ACTIVE	SOT-23	DBV	5	3000	Green (RoHS & no Sb/Br)	CU SN	Level-1-260C-UNLIM	-40 to 125	18RD	Samples
INA180B1IDBVT	ACTIVE	SOT-23	DBV	5	250	Green (RoHS & no Sb/Br)	CU SN	Level-1-260C-UNLIM	-40 to 125	18RD	Samples
INA180B2IDBVR	ACTIVE	SOT-23	DBV	5	3000	Green (RoHS & no Sb/Br)	CU SN	Level-1-260C-UNLIM	-40 to 125	1ABD	Samples
INA180B2IDBVT	ACTIVE	SOT-23	DBV	5	250	Green (RoHS & no Sb/Br)	CU SN	Level-1-260C-UNLIM	-40 to 125	1ABD	Samples
INA180B3IDBVR	ACTIVE	SOT-23	DBV	5	3000	Green (RoHS & no Sb/Br)	CU SN	Level-1-260C-UNLIM	-40 to 125	1ACD	Samples
INA180B3IDBVT	ACTIVE	SOT-23	DBV	5	250	Green (RoHS & no Sb/Br)	CU SN	Level-1-260C-UNLIM	-40 to 125	1ACD	Samples
INA180B4IDBVR	ACTIVE	SOT-23	DBV	5	3000	Green (RoHS & no Sb/Br)	CU SN	Level-1-260C-UNLIM	-40 to 125	1ADD	Samples
INA180B4IDBVT	ACTIVE	SOT-23	DBV	5	250	Green (RoHS & no Sb/Br)	CU SN	Level-1-260C-UNLIM	-40 to 125	1ADD	Samples
INA2180A1IDGKR	ACTIVE	VSSOP	DGK	8	2500	Green (RoHS & no Sb/Br)	CU NIPDAUAG	Level-2-260C-1 YEAR	-40 to 125	1CX6	Samples

Orderable Device	Status (1)	Package Type	Package Drawing	Pins	Package Qty	Eco Plan (2)	Lead/Ball Finish (6)	MSL Peak Temp (3)	Op Temp (°C)	Device Marking (4/5)	Samples
INA2180A1IDGKT	ACTIVE	VSSOP	DGK	8	250	Green (RoHS & no Sb/Br)	CU NIPDAUAG	Level-2-260C-1 YEAR	-40 to 125	1CX6	Samples
INA2180A2IDGKR	ACTIVE	VSSOP	DGK	8	2500	Green (RoHS & no Sb/Br)	CU NIPDAUAG	Level-2-260C-1 YEAR	-40 to 125	1CZ6	Samples
INA2180A2IDGKT	ACTIVE	VSSOP	DGK	8	250	Green (RoHS & no Sb/Br)	CU NIPDAUAG	Level-2-260C-1 YEAR	-40 to 125	1CZ6	Samples
INA2180A3IDGKR	ACTIVE	VSSOP	DGK	8	2500	Green (RoHS & no Sb/Br)	CU NIPDAUAG	Level-2-260C-1 YEAR	-40 to 125	1D16	Samples
INA2180A3IDGKT	ACTIVE	VSSOP	DGK	8	250	Green (RoHS & no Sb/Br)	CU NIPDAUAG	Level-2-260C-1 YEAR	-40 to 125	1D16	Samples
INA2180A4IDGKR	ACTIVE	VSSOP	DGK	8	2500	Green (RoHS & no Sb/Br)	CU NIPDAUAG	Level-2-260C-1 YEAR	-40 to 125	1D26	Samples
INA2180A4IDGKT	ACTIVE	VSSOP	DGK	8	250	Green (RoHS & no Sb/Br)	CU NIPDAUAG	Level-2-260C-1 YEAR	-40 to 125	1D26	Samples
INA4180A1IPWR	PREVIEW	TSSOP	PW	14	2000	TBD	Call TI	Call TI	-40 to 125		
INA4180A2IPWR	PREVIEW	TSSOP	PW	14	2000	TBD	Call TI	Call TI	-40 to 125		
INA4180A3IPWR	PREVIEW	TSSOP	PW	14	2000	TBD	Call TI	Call TI	-40 to 125		
INA4180A4IPWR	PREVIEW	TSSOP	PW	14	2000	TBD	Call TI	Call TI	-40 to 125		
PINA4180A1PW	ACTIVE	TSSOP	PW	14	90	TBD	Call TI	Call TI	-40 to 125		Samples
PINA4180A2PW	ACTIVE	TSSOP	PW	14	90	TBD	Call TI	Call TI	-40 to 125		Samples
PINA4180A3PW	ACTIVE	TSSOP	PW	14	90	TBD	Call TI	Call TI	-40 to 125		Samples
PINA4180A4PW	ACTIVE	TSSOP	PW	14	90	TBD	Call TI	Call TI	-40 to 125		Samples

(1) The marketing status values are defined as follows:

ACTIVE: Product device recommended for new designs.

LIFEBUY: TI has announced that the device will be discontinued, and a lifetime-buy period is in effect.

NRND: Not recommended for new designs. Device is in production to support existing customers, but TI does not recommend using this part in a new design.

PREVIEW: Device has been announced but is not in production. Samples may or may not be available.

OBSELETE: TI has discontinued the production of the device.

(2) **RoHS:** TI defines "RoHS" to mean semiconductor products that are compliant with the current EU RoHS requirements for all 10 RoHS substances, including the requirement that RoHS substance do not exceed 0.1% by weight in homogeneous materials. Where designed to be soldered at high temperatures, "RoHS" products are suitable for use in specified lead-free processes. TI may reference these types of products as "Pb-Free".

RoHS Exempt: TI defines "RoHS Exempt" to mean products that contain lead but are compliant with EU RoHS pursuant to a specific EU RoHS exemption.

Green: TI defines "Green" to mean the content of Chlorine (Cl) and Bromine (Br) based flame retardants meet JS709B low halogen requirements of ≤ 1000 ppm threshold. Antimony trioxide based flame retardants must also meet the ≤ 1000 ppm threshold requirement.

(3) MSL, Peak Temp. - The Moisture Sensitivity Level rating according to the JEDEC industry standard classifications, and peak solder temperature.

(4) There may be additional marking, which relates to the logo, the lot trace code information, or the environmental category on the device.

(5) Multiple Device Markings will be inside parentheses. Only one Device Marking contained in parentheses and separated by a "~" will appear on a device. If a line is indented then it is a continuation of the previous line and the two combined represent the entire Device Marking for that device.

(6) Lead/Ball Finish - Orderable Devices may have multiple material finish options. Finish options are separated by a vertical ruled line. Lead/Ball Finish values may wrap to two lines if the finish value exceeds the maximum column width.

Important Information and Disclaimer: The information provided on this page represents TI's knowledge and belief as of the date that it is provided. TI bases its knowledge and belief on information provided by third parties, and makes no representation or warranty as to the accuracy of such information. Efforts are underway to better integrate information from third parties. TI has taken and continues to take reasonable steps to provide representative and accurate information but may not have conducted destructive testing or chemical analysis on incoming materials and chemicals. TI and TI suppliers consider certain information to be proprietary, and thus CAS numbers and other limited information may not be available for release.

In no event shall TI's liability arising out of such information exceed the total purchase price of the TI part(s) at issue in this document sold by TI to Customer on an annual basis.

GENERIC PACKAGE VIEW

DBV 5

SOT-23 - 1.45 mm max height

SMALL OUTLINE TRANSISTOR



Images above are just a representation of the package family, actual package may vary.
Refer to the product data sheet for package details.

4073253/P

DBV0005A



PACKAGE OUTLINE

SOT-23 - 1.45 mm max height

SMALL OUTLINE TRANSISTOR



4214839/C 04/2017

NOTES:

1. All linear dimensions are in millimeters. Any dimensions in parenthesis are for reference only. Dimensioning and tolerancing per ASME Y14.5M.
2. This drawing is subject to change without notice.
3. Reference JEDEC MO-178.

EXAMPLE BOARD LAYOUT

DBV0005A

SOT-23 - 1.45 mm max height

SMALL OUTLINE TRANSISTOR



LAND PATTERN EXAMPLE
EXPOSED METAL SHOWN
SCALE:15X



SOLDER MASK DETAILS

4214839/C 04/2017

NOTES: (continued)

- 4. Publication IPC-7351 may have alternate designs.
- 5. Solder mask tolerances between and around signal pads can vary based on board fabrication site.

EXAMPLE STENCIL DESIGN

DBV0005A

SOT-23 - 1.45 mm max height

SMALL OUTLINE TRANSISTOR



SOLDER PASTE EXAMPLE
BASED ON 0.125 mm THICK STENCIL
SCALE:15X

4214839/C 04/2017

NOTES: (continued)

6. Laser cutting apertures with trapezoidal walls and rounded corners may offer better paste release. IPC-7525 may have alternate design recommendations.
7. Board assembly site may have different recommendations for stencil design.

PW (R-PDSO-G14)

PLASTIC SMALL OUTLINE



- NOTES:
- A. All linear dimensions are in millimeters. Dimensioning and tolerancing per ASME Y14.5M-1994.
 - B. This drawing is subject to change without notice.
 - C. Body length does not include mold flash, protrusions, or gate burrs. Mold flash, protrusions, or gate burrs shall not exceed 0,15 each side.
 - D. Body width does not include interlead flash. Interlead flash shall not exceed 0,25 each side.
 - E. Falls within JEDEC MO-153

DGK (S-PDSO-G8)

PLASTIC SMALL-OUTLINE PACKAGE



- NOTES:
- A. All linear dimensions are in millimeters.
 - B. This drawing is subject to change without notice.
 - C. Body length does not include mold flash, protrusions, or gate burrs. Mold flash, protrusions, or gate burrs shall not exceed 0.15 per end.
 - D. Body width does not include interlead flash. Interlead flash shall not exceed 0.50 per side.
 - E. Falls within JEDEC MO-187 variation AA, except interlead flash.



- NOTES:
- A. All linear dimensions are in millimeters.
 - B. This drawing is subject to change without notice.
 - C. Publication IPC-7351 is recommended for alternate designs.
 - D. Laser cutting apertures with trapezoidal walls and also rounding corners will offer better paste release. Customers should contact their board assembly site for stencil design recommendations. Refer to IPC-7525 for other stencil recommendations.
 - E. Customers should contact their board fabrication site for solder mask tolerances between and around signal pads.

IMPORTANT NOTICE

Texas Instruments Incorporated (TI) reserves the right to make corrections, enhancements, improvements and other changes to its semiconductor products and services per JESD46, latest issue, and to discontinue any product or service per JESD48, latest issue. Buyers should obtain the latest relevant information before placing orders and should verify that such information is current and complete.

TI's published terms of sale for semiconductor products (<http://www.ti.com/sc/docs/stdterms.htm>) apply to the sale of packaged integrated circuit products that TI has qualified and released to market. Additional terms may apply to the use or sale of other types of TI products and services.

Reproduction of significant portions of TI information in TI data sheets is permissible only if reproduction is without alteration and is accompanied by all associated warranties, conditions, limitations, and notices. TI is not responsible or liable for such reproduced documentation. Information of third parties may be subject to additional restrictions. Resale of TI products or services with statements different from or beyond the parameters stated by TI for that product or service voids all express and any implied warranties for the associated TI product or service and is an unfair and deceptive business practice. TI is not responsible or liable for any such statements.

Buyers and others who are developing systems that incorporate TI products (collectively, "Designers") understand and agree that Designers remain responsible for using their independent analysis, evaluation and judgment in designing their applications and that Designers have full and exclusive responsibility to assure the safety of Designers' applications and compliance of their applications (and of all TI products used in or for Designers' applications) with all applicable regulations, laws and other applicable requirements. Designer represents that, with respect to their applications, Designer has all the necessary expertise to create and implement safeguards that (1) anticipate dangerous consequences of failures, (2) monitor failures and their consequences, and (3) lessen the likelihood of failures that might cause harm and take appropriate actions. Designer agrees that prior to using or distributing any applications that include TI products, Designer will thoroughly test such applications and the functionality of such TI products as used in such applications.

TI's provision of technical, application or other design advice, quality characterization, reliability data or other services or information, including, but not limited to, reference designs and materials relating to evaluation modules, (collectively, "TI Resources") are intended to assist designers who are developing applications that incorporate TI products; by downloading, accessing or using TI Resources in any way, Designer (individually or, if Designer is acting on behalf of a company, Designer's company) agrees to use any particular TI Resource solely for this purpose and subject to the terms of this Notice.

TI's provision of TI Resources does not expand or otherwise alter TI's applicable published warranties or warranty disclaimers for TI products, and no additional obligations or liabilities arise from TI providing such TI Resources. TI reserves the right to make corrections, enhancements, improvements and other changes to its TI Resources. TI has not conducted any testing other than that specifically described in the published documentation for a particular TI Resource.

Designer is authorized to use, copy and modify any individual TI Resource only in connection with the development of applications that include the TI product(s) identified in such TI Resource. NO OTHER LICENSE, EXPRESS OR IMPLIED, BY ESTOPPEL OR OTHERWISE TO ANY OTHER TI INTELLECTUAL PROPERTY RIGHT, AND NO LICENSE TO ANY TECHNOLOGY OR INTELLECTUAL PROPERTY RIGHT OF TI OR ANY THIRD PARTY IS GRANTED HEREIN, including but not limited to any patent right, copyright, mask work right, or other intellectual property right relating to any combination, machine, or process in which TI products or services are used. Information regarding or referencing third-party products or services does not constitute a license to use such products or services, or a warranty or endorsement thereof. Use of TI Resources may require a license from a third party under the patents or other intellectual property of the third party, or a license from TI under the patents or other intellectual property of TI.

TI RESOURCES ARE PROVIDED "AS IS" AND WITH ALL FAULTS. TI DISCLAIMS ALL OTHER WARRANTIES OR REPRESENTATIONS, EXPRESS OR IMPLIED, REGARDING RESOURCES OR USE THEREOF, INCLUDING BUT NOT LIMITED TO ACCURACY OR COMPLETENESS, TITLE, ANY EPIDEMIC FAILURE WARRANTY AND ANY IMPLIED WARRANTIES OF MERCHANTABILITY, FITNESS FOR A PARTICULAR PURPOSE, AND NON-INFRINGEMENT OF ANY THIRD PARTY INTELLECTUAL PROPERTY RIGHTS. TI SHALL NOT BE LIABLE FOR AND SHALL NOT DEFEND OR INDEMNIFY DESIGNER AGAINST ANY CLAIM, INCLUDING BUT NOT LIMITED TO ANY INFRINGEMENT CLAIM THAT RELATES TO OR IS BASED ON ANY COMBINATION OF PRODUCTS EVEN IF DESCRIBED IN TI RESOURCES OR OTHERWISE. IN NO EVENT SHALL TI BE LIABLE FOR ANY ACTUAL, DIRECT, SPECIAL, COLLATERAL, INDIRECT, PUNITIVE, INCIDENTAL, CONSEQUENTIAL OR EXEMPLARY DAMAGES IN CONNECTION WITH OR ARISING OUT OF TI RESOURCES OR USE THEREOF, AND REGARDLESS OF WHETHER TI HAS BEEN ADVISED OF THE POSSIBILITY OF SUCH DAMAGES.

Unless TI has explicitly designated an individual product as meeting the requirements of a particular industry standard (e.g., ISO/TS 16949 and ISO 26262), TI is not responsible for any failure to meet such industry standard requirements.

Where TI specifically promotes products as facilitating functional safety or as compliant with industry functional safety standards, such products are intended to help enable customers to design and create their own applications that meet applicable functional safety standards and requirements. Using products in an application does not by itself establish any safety features in the application. Designers must ensure compliance with safety-related requirements and standards applicable to their applications. Designer may not use any TI products in life-critical medical equipment unless authorized officers of the parties have executed a special contract specifically governing such use. Life-critical medical equipment is medical equipment where failure of such equipment would cause serious bodily injury or death (e.g., life support, pacemakers, defibrillators, heart pumps, neurostimulators, and implantables). Such equipment includes, without limitation, all medical devices identified by the U.S. Food and Drug Administration as Class III devices and equivalent classifications outside the U.S.

TI may expressly designate certain products as completing a particular qualification (e.g., Q100, Military Grade, or Enhanced Product). Designers agree that it has the necessary expertise to select the product with the appropriate qualification designation for their applications and that proper product selection is at Designers' own risk. Designers are solely responsible for compliance with all legal and regulatory requirements in connection with such selection.

Designer will fully indemnify TI and its representatives against any damages, costs, losses, and/or liabilities arising out of Designer's non-compliance with the terms and provisions of this Notice.