

REVISION RECORD				
REV	ECN	DESCRIPTION	DRFT	DATE

NOTES1:

UL Standard

- 1.Rated Voltage/Current : 300V / 10A
- 2.Withstanding Voltage : AC1600V/1Min.
- 3.Wire Range : 26~12AWG

IEC Standard

1. Pollution Degree	2
Overvoltage Category	III
Rate Impulse Voltage(KV)	4KV
Rate Voltage(V)	320V
Rate Current(A)	20A

2.Wire Range : 0.2~2.5mm²

NOTES2:

- 1.Dimension shall be interpreted per ASME Y14.5-2009
- 2.Pitch : 5.00/5.08mm, Poles : N=02-24P
- 3.Stripping length : 9~10mm
- 4.Operating temperature: -40°C~+105°C
- 5.Undimensioned Tolerances:

Pitch range in mm		Nominal dimension range in mm				Tolerance	
TO	TO	TO	TO	TO	TO	TO	TO
6	10	30	60	100	150	0.1/10	<
±0.15	±0.20	±0.30	±0.50	±0.70	±1.00	±1.30	±2'

6.RoHS Compliance

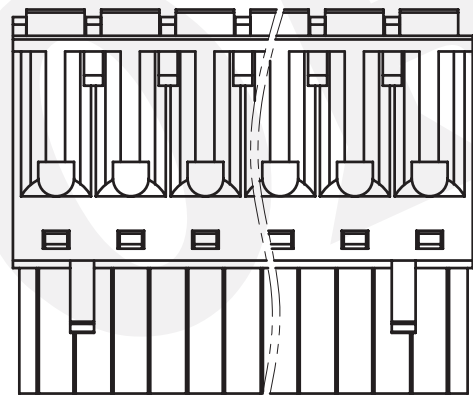
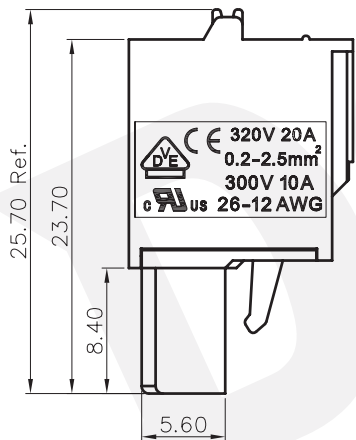
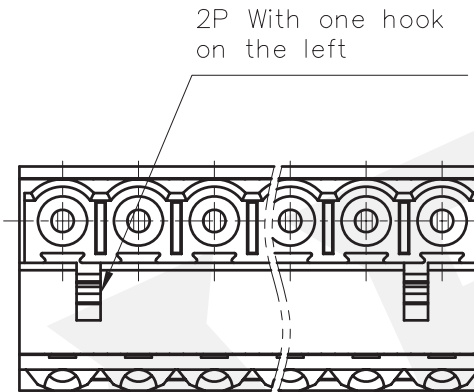
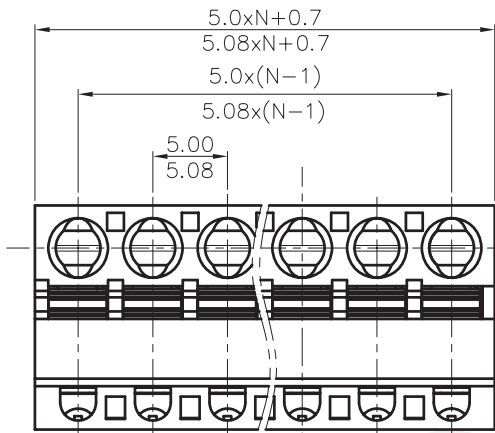

DB2EKD - 5.0/5.08 - XXP - 1Y - 00A (H)

(Series No.) (Pitch) (Poles) (Single Pitch) (Color): 1.(Grey)
 2.(Blue)
 3.(Black)
 4.(Green)
 5.(Orange)
 6.(Red)
 7.(Transparent)
 8.(Yellow)
 9.(White)

(RoHS)
 00A-(Standard)

DETACHED LISTS	PART NO.:	DORABO 慈溪市地博电子有限公司 CIXI DORABO ELECTRONICS CO.,LTD			
	APPD:	NAME: DB2EKD-5.0/5.08-XXP-1Y-00A(H)			
	CHKD:	TITLE: CUSTOMER DRAWING			
	DRFT:	DRAWING NO.:		REV	DO
THIRD ANGLE PROJECTION		MM (INCH)	DO NOT SCALE DRAWING	SHEET 1/1	SCALE 1:1