

MH188 Hall-effect sensor is a temperature stable, stress-resistant sensor. Superior high-temperature performance is made possible through a dynamic offset cancellation that utilizes chopper-stabilization. This method reduces the offset voltage normally caused by device over molding, temperature dependencies, and thermal stress.

MH188 includes the following on a single silicon chip: voltage regulator, Hall voltage generator, small-signal amplifier, chopper stabilization, Schmitt trigger, Advanced DMOS wafer fabrication processing is used to take advantage of low-voltage requirements, component matching, very low input-offset errors, and small component geometries.

This device requires the presence of both south and north polarity magnetic fields for operation. In the presence of a south polarity field of sufficient strength, the device output sensor on, and only switches off when a north polarity field of sufficient strength is present.

MH188 is rated for operation between the ambient temperatures -40°C and 85°C for the E temperature range, and -40°C to 125°C for the K temperature range. The two package styles available provide magnetically optimized solutions for most applications. Package SO is a SOT-23, a miniature low-profile surface-mount package, while package UA is a three-lead ultra mini SIP for through-hole mounting.

Packages is Halogen Free standard and which have been verified by third party lab.

Features and Benefits

- DMOS Hall IC Technology.
- Reverse bias protection on power supply pin.
- Chopper stabilized amplifier stage.
- Optimized for BLDC motor applications.
- Reliable and low shifting on high Temp condition.
- Switching offset compensation at typically 69 kHz.
- Good ESD Protection.
- 100% tested at 125°C for K.
- Custom sensitivity / Temperature selection are available.
- RoHS compliant 2011/65/EU and Halogen Free

Applications

- High temperature Fan motor
- 3 phase BLDC motor application
- Speed sensing
- Position sensing
- Current sensing
- Revolution counting
- Solid-State Switch
- Linear Position Detection
- Angular Position Detection
- Proximity Detection
- High ESD Capability

Ordering Information

	<p>Company Name and Product Category</p> <p>MH:MST Hall Effect/MP:MST Power IC</p> <p>Part number</p> <p>181,182,183,184,185,248,249,276,477,381,381F,381R,382.....</p> <p>If part # is just 3 digits, the forth digit will be omitted.</p> <p>Temperature range</p> <p>E: 85 °C, I: 105 °C, K: 125 °C, L: 150 °C</p> <p>Package type</p> <p>UA:TO-92S,VK:TO-92S(4pin),VF:TO-92S(5pin),SO:SOT-23, SQ:QFN-3,ST:TSOT-23,SN:SOT-553,SF:SOT-89(5pin), SS:TSOT-26,SD:DFN-6</p> <p>Sorting</p> <p>α,β,Blank.....</p>
<p>Sorting Code</p> <p>Package type</p> <p>Temperature Code</p> <p>Part number</p> <p>Company Name and product Category</p>	

Part No.	Temperature Suffix	Package Type
MH188KUA	K (-40°C to + 125°C)	UA (TO-92S)
MH188KSO	K (-40°C to + 125°C)	SO (SOT-23)
MH188EUA	E (-40°C to + 85°C)	UA (TO-92S)
MH188ESO	E (-40°C to + 85°C)	SO (SOT-23)
MH188ESD	E(-40°C to +85°C)	SD (DFN2*2-6L)

KUA spec is using in industrial and automotive application. Special Hot Testing is utilized.

Functional Diagram

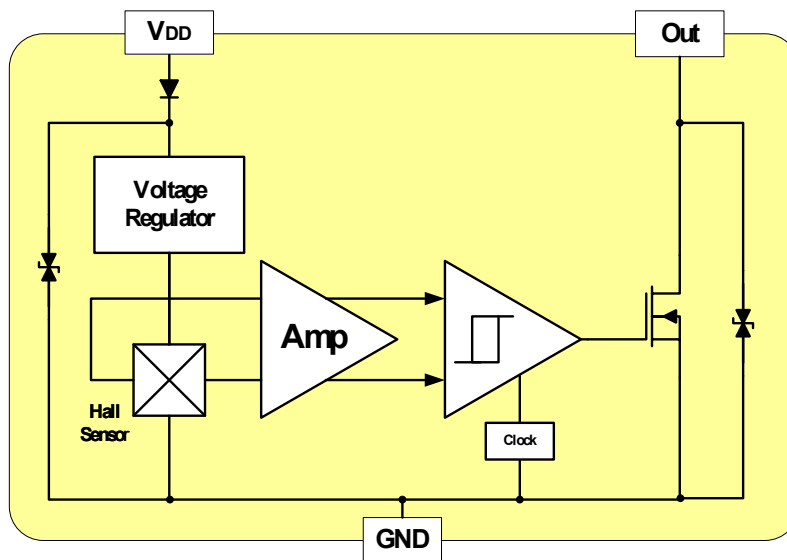

Absolute Maximum Ratings At ($T_a=25^{\circ}\text{C}$)

Characteristics		Values	Unit
Supply voltage, (V_{DD})		28	V
Output Voltage, (V_{out})		28	V
Reverse voltage, (V_{DD})		-28/-0.3	V
Output current, (I_{out})		50	mA
Operating Temperature Range, (T_a)	“E” version	-40 to +85	$^{\circ}\text{C}$
	“K” version	-40 to +125	$^{\circ}\text{C}$
Storage temperature range, (T_s)		-65 to +150	$^{\circ}\text{C}$
Maximum Junction Temp, (T_j)		150	$^{\circ}\text{C}$
Thermal Resistance	(θ_{ja}) UA / SO	206 / 543	$^{\circ}\text{C}/\text{W}$
	(θ_{je}) UA / SO	148 / 410	$^{\circ}\text{C}/\text{W}$
Package Power Dissipation, (P_D) UA / SO		606 / 230	mW

Note: Do not apply reverse voltage to V_{DD} and V_{OUT} Pin, It may be caused for Miss function or damaged device.

Electrical Specifications

DC Operating Parameters : $T_A=+25^{\circ}\text{C}$, $V_{DD}=12\text{V}$

Parameters	Test Conditions	Min	Typ	Max	Units
Supply Voltage, (V_{DD})	Operating	2.5		26.0	V
Supply Current, (I_{DD})	B<BOP			5.0	mA
Output Saturation Voltage, (V_{sat})	$I_{out}=20\text{mA}$, B>BOP			400.0	mV
Output Leakage Current, (I_{off})	I_{OFF} B<B _{RP} , $V_{OUT} = 12\text{V}$			10.0	μA
Power-On Time, (T_{PO})	Power-On		0.05	0.10	μS
Output Response Time, (T_{RES})	Operating		0.30	0.65	mS
Output Switch Frequency, (F_{SW})	Operating	3			kHz
Output Rise Time, (T_R)	$R_L=1\text{K}\Omega$, $C_L=20\text{pF}$		0.12	0.35	μS
Output Fall Time, (T_F)	$R_L=1\text{K}\Omega$; $C_L=20\text{pF}$		0.05	0.15	μS
Electro-Static Discharge	HBM	4			KV
Operate Point, (B_{OP})	UA、SD (SO)	5(-25)		25(-5)	Gauss
Release Point, (B_{RP})	UA、SD (SO)	-25(5)		-5(25)	Gauss
Hysteresis, (B_{HYS})			30		Gauss

Typical application circuit

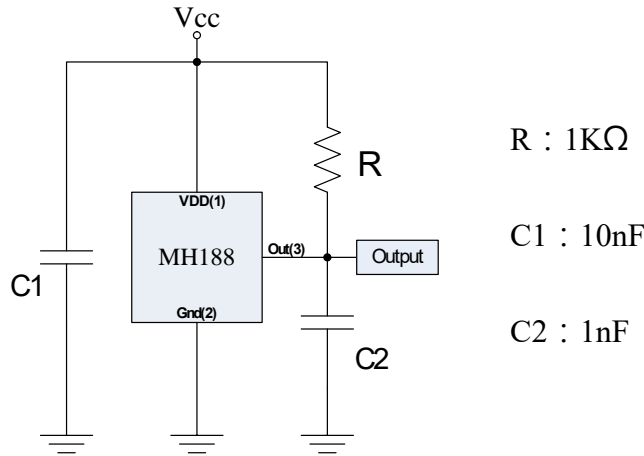

Sensor Location, Package Dimension and Marking

UA Package

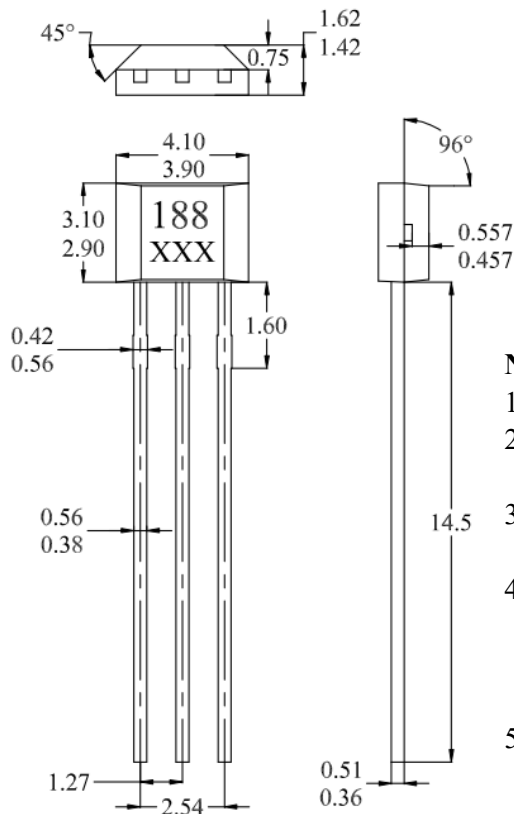

Hall Chip location

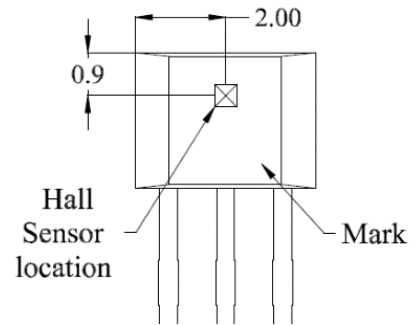

NOTES:

1. Controlling dimension: mm
2. Leads must be free of flash and plating voids
3. Do not bend leads within 1 mm of lead to package interface.
4. PINOUT:
Pin 1 VCC
Pin 2 GND
Pin 3 Output
5. XXX; 1st X=Year;
2nd and 3rd XX=Week

Output Pin Assignment

(Top view)

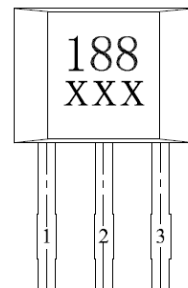

Package (SOT-23) (Top View)

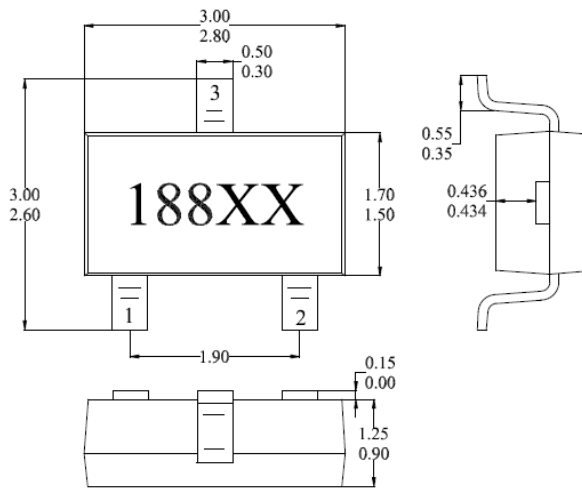

Hall Plate Chip Location (Bottom view)

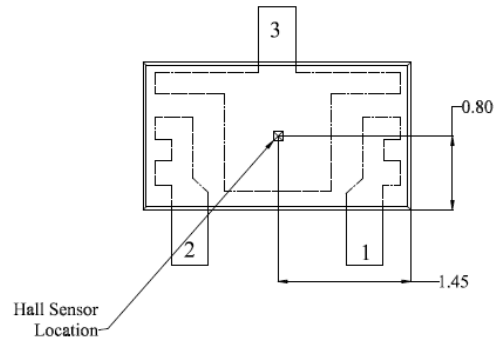

(For reference only) Land Pattern

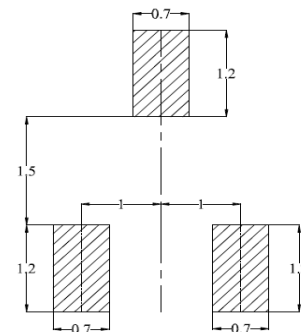

NOTES:

- PINOUT (See Top View at left :)
Pin 1 : V_{DD}; Pin 2: Output ; Pin 3 GND
- Controlling dimension: mm
- Lead thickness after solder plating will be 0.254mm maximum
- XX: Date Code, Refer to DC table

SD Package

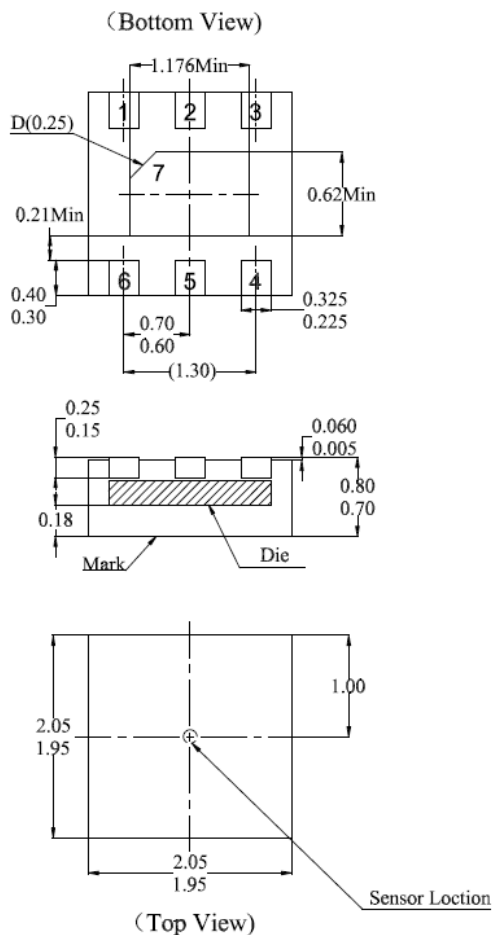

NOTES:

- Controlling dimension: mm
- Leads must be free of flash and plating voids
- Lead thickness after solder plating will be 0.254mm maximum
- PINOUT:

Pin No.	Pin Name	Function
1	V _{DD}	Power Supply
2	N.C	N.C
3	V _{OUT}	Output
4	N.C	N.C
5	V _{SS}	Ground
6	N.C	N.C
7	N.C	N.C

- (For reference only) Land pattern

