

SERIES: AMT11 | **DESCRIPTION:** MODULAR INCREMENTAL ENCODER

FEATURES

- patented capacitive ASIC technology
- low power consumption
- incremental resolutions up to 4096 PPR
- resolutions programmable with AMT Viewpoint™ PC software
- differential line driver versions
- digitally set zero position
- compact modular package with locking hub for ease of installation
- radial and axial cable connections
- 7 different mounting hole options
- -40~125°C operating temperature

ELECTRICAL

| parameter | conditions/description | min | typ | max | units |
|------------------------------|------------------------------|---------|-----|-----|-------|
| power supply | VDD | 4.5 | 5 | 5.5 | V |
| start-up time ¹ | | | 200 | | ms |
| current consumption | with unloaded output | | 16 | | mA |
| single ended channels | output high level | VDD-0.1 | | | V |
| | output low level | | | 0.1 | V |
| | output current (per channel) | | | 15 | mA |
| | rise/fall time | | 8 | | ns |
| differential RS-422 channels | output high level | 3 | | | V |
| | output low level | | | 0.1 | V |
| | output current (per channel) | | | 25 | mA |
| | rise/fall time | 7 | 11 | 20 | ns |

Note: 1. Encoder must be stationary during start-up.

INCREMENTAL CHARACTERISTICS

| parameter | conditions/description | min | typ | max | units |
|--|---|-----|-----|-----|--|
| channels | CMOS Voltage (S) | | | | A, B, Z |
| | Quadrature Line Driver (Q) | | | | A, \bar{A} , B, \bar{B} , Z, \bar{Z} |
| waveform | CMOS voltage square wave | | | | |
| phase difference | A leads B for CCW rotation (viewed from front) | | | | |
| quadrature resolutions ² | 48, 96, 100, 125, 192, 200, 250, 256, 360, 384, 400, 500, 512, 768, 800, 1000, 1024, 1600, 2000, 2048, 2500, 4096 | | | | PPR |
| index ³ | one pulse per 360 degree rotation | | | | |
| accuracy | | | 0.2 | | degrees |
| quadrature duty cycle [at each resolution] | 48, 96, 100, 125, 192, 256, 384 | 49 | 50 | 51 | % |
| | 200, 250, 360, 400, 768, 800 | 48 | 50 | 52 | % |
| | 500, 1000, 1600 | 46 | 50 | 54 | % |
| | 512, 1024, 2048, 4096 | 50 | 50 | 50 | % |
| | 2000 | 44 | 50 | 56 | % |
| | 2500 | 43 | 50 | 57 | % |

Notes: 2. Resolution programmed with AMT Viewpoint™ PC software. Default resolution set to 2048 PPR. All resolutions are listed as pre-quadrature, meaning the final number of counts is PPR x 4.

3. Zero position alignment set with AMT One Touch Zero™ module, AMT Viewpoint™ PC software, or serial commands

MECHANICAL

| parameter | conditions/description | min | typ | max | units |
|---------------------------------------|---|-----|---------------|------|-------|
| motor shaft length | | 9 | | | mm |
| motor shaft tolerance | | | NOM +0/-0.015 | | mm |
| weight | weight varies by configuration | | 15.7 | | g |
| axial play | | | | +0.3 | mm |
| rotational speed (at each resolution) | 48, 96, 100, 125, 192, 200, 250, 256, 384, 400, 500, 512, 800, 1000, 1024, 2048 | | | 8000 | RPM |
| | 360, 768, 1600, 2000, 4096 | | | 4000 | RPM |
| | 2500 | | | 2500 | RPM |

ENVIRONMENTAL

| parameter | conditions/description | min | typ | max | units |
|-----------------------|--|-----|-----|-----|-------|
| operating temperature | | -40 | | 125 | °C |
| humidity | non-condensing | | | 85 | % |
| vibration | 10-500 Hz, 5 minute sweep, 2 hours on each XYZ | | | 5 | G |
| shock | 3 pulses, 6 ms, 3 on each XYZ | | | 200 | G |
| RoHS | yes | | | | |

SERIAL INTERFACE

| parameter | conditions/description | min | typ | max | units |
|------------|--|-----|--------|-----|-------|
| protocol | serial UART | | | | |
| controller | driven by onboard Microchip PIC18F25K80. See Microchip documentation for additional details. | | | | |
| data rate | 8 data bits, no parity, 1 stop bit, least significant bit first | | 115200 | | baud |

WAVEFORMS

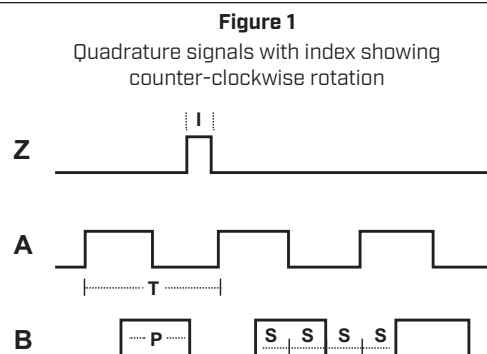

The following parameters are defined by the resolution selected for each encoder. The encoders resolution is listed as Pulses Per Revolution (PPR), which is the number of periods (or high pulses) over the encoders revolution.

| Parameter | Description | Expression | Units | Notes |
|-----------|-----------------|------------|-----------------------|--|
| PPR | resolution | | Pulses Per Revolution | This is the user selected value and the format all resolutions are listed in |
| CPR | counts | PPR x 4 | Counts Per Revolution | This is the number of quadrature counts the encoder has |
| T | period | 360/R | mechanical degrees | |
| P | pulse width | T/2 | mechanical degrees | |
| S | A/B state width | T/4 | mechanical degrees | This is the width of a quadrature state |
| I | index width | T/4 | mechanical degrees | The width of a once per turn index is the state width for A & B lines |

Note: For more information regarding PPR, CPR, or LPR (Lines Per Revolution) view <https://www.cuidevices.com/blog/what-is-encoder-ppr-cpr-and-lpr>

PART NUMBER KEY

For customers that prefer a specific AMT11 configuration, please reference the custom configuration key below.



AMT11-V KITS

In order to provide maximum flexibility for our customers, the AMT11 series is provided in kit form standard. This allows the user to implement the encoder into a range of applications using one sku#, reducing engineering and inventory costs.

ORDERING GUIDE

AMT11XX-V

Orientation:
2 = Radial
3 = Axial

Output Signals:
S = CMOS Voltage
Q = Quadrature Line Driver

| SLEEVES | | | | | | | | |
|----------------|--------|--------------------|------|--------------------|-------|-----|-------------------|------|
| | | | | | | | | |
| 2mm | 3mm | 1/8 inch (3.175mm) | 4mm | 3/16 inch (4.76mm) | 5mm | 6mm | 1/4 inch (6.35mm) | 8mm |
| Light Sky Blue | Orange | Purple | Gray | Yellow | Green | Red | Snow | Blue |

| BASE | WIDE BASE | TOP COVER | SHAFT ADAPTER | TOOL A | TOOL C |
|------|-----------|-----------|---------------|--------|--------|
| | | | | | |

ENCODER INTERFACE

| PINOUT CONNECTOR | | | | |
|------------------|------------------|------------------|------------------|------------------|
| Function | | | | |
| # | AMT112S | AMT112Q | AMT113S | AMT113Q |
| 1 | TX_ENC+ | TX_ENC+ | RX_ENC+ | RX_ENC+ |
| 2 | RX_ENC+ | RX_ENC+ | TX_ENC+ | TX_ENC+ |
| 3 | N/A | N/A | N/A | N/A |
| 4 | GND ¹ | GND ¹ | GND ¹ | GND ¹ |
| 5 | N/A | N/A | N/A | N/A |
| 6 | +5 V | +5 V | +5 V | +5 V |
| 7 | N/A | N/A | N/A | N/A |
| 8 | B+ | B+ | B+ | B+ |
| 9 | N/A | B- | N/A | B- |
| 10 | A+ | A+ | A+ | A+ |
| 11 | N/A | A- | N/A | A- |
| 12 | Z+ | Z+ | Z+ | Z+ |
| 13 | N/A | Z- | N/A | Z- |
| 14 | MCLR B | MCLR B | MCLR B | MCLR B |
| 15 | N/A | N/A | N/A | N/A |
| 16 | N/A | N/A | N/A | N/A |
| 17 | N/A | N/A | N/A | N/A |

Note: 1. Connect encoder GND to motor chassis as closely as possible. For additional grounding techniques contact CUI Devices Application Support.

AMT112S & AMT112Q

AMT113S & AMT113Q

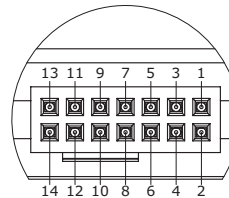
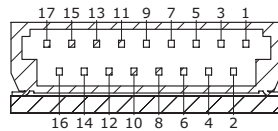
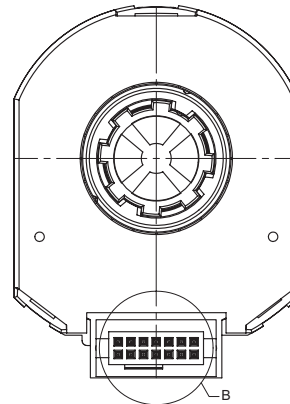
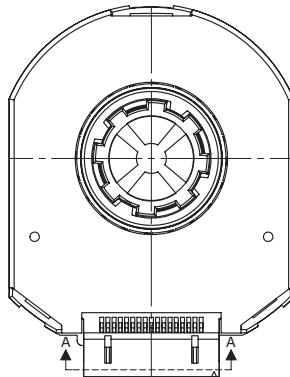

SECTION A-A
SCALE 4 : 1

DETAIL B
SCALE 4 : 1

Mating Connector:
JAE FI-W17S

Mating Connector:
Samtec ISDF-07-D-L

MECHANICAL DRAWING

AMT112S & AMT112Q

units: mm[inch]

tolerance: ±0.1

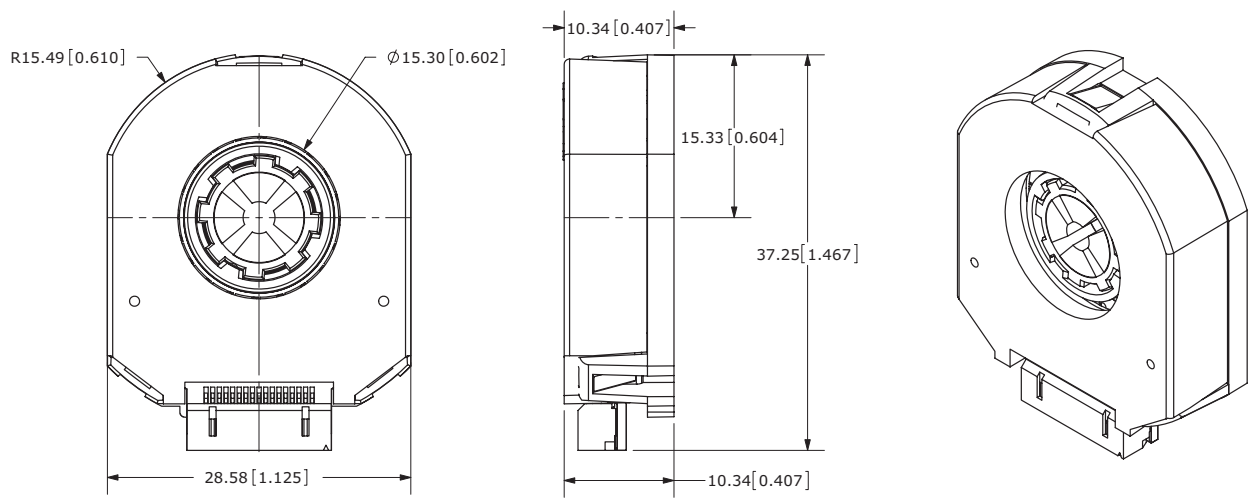

AMT113S & AMT113Q

units: mm[inch]

tolerance: ±0.1

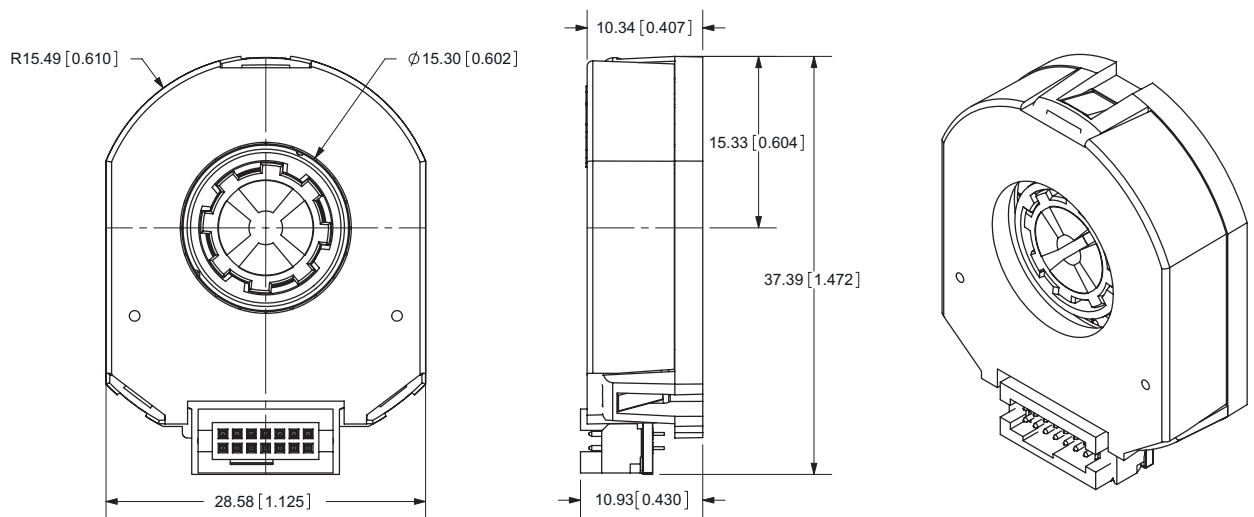

MECHANICAL DRAWING (CONTINUED)

MOUNTING HOLE PATTERNS

STANDARD BASE

units: mm[inch]
tolerance: ±0.1

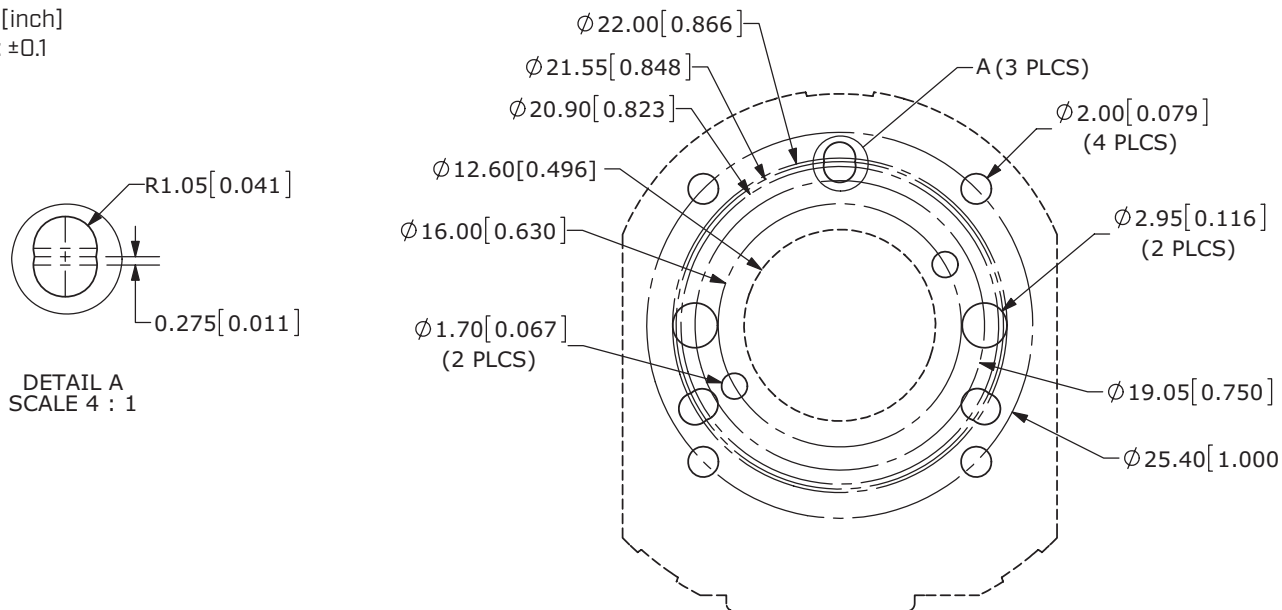

WIDE BASE

units: mm[inch]
tolerance: ±0.1

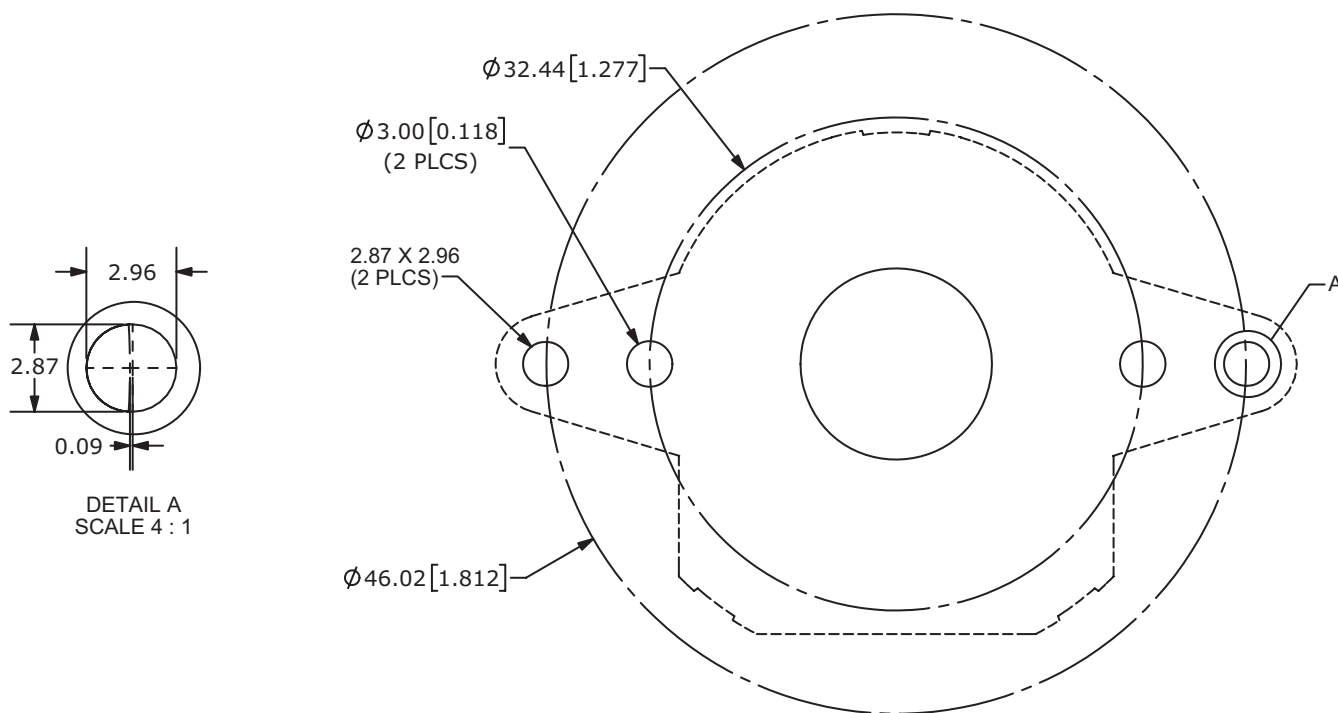

ASSEMBLY PROCEDURE

STEP 1



1. Insert Tool A as a spacer that defines the distance to the mounting surface.
2. Slide appropriate sized Sleeve over shaft all the way down to Tool A.
3. Slide Shaft Adaptor over Sleeve.
4. Use Tool C to press Shaft Adaptor over Sleeve [ensure Shaft Adaptor and Tool C spline alignment] until flush with Tool A.

STEP 2



1. Remove Tools A and C.
2. Place Base on motor, with Tool C used as a centering tool.

STEP 3

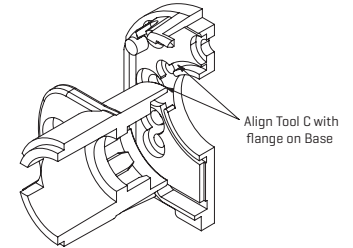

1. Align Tool C with flange on Base.
2. Slide Base and Tool C onto motor, centering onto the Shaft Adaptor.

STEP 4



1. Fasten the Base on the motor (Tool C may need to be rotated to allow for some mounting configurations).
2. Remove Tool C.

STEP 5

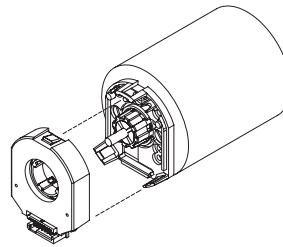

1. Snap the Top Cover onto the Base, carefully observing that the teeth of the Shaft Adaptor align with the grooves in the hub. *
- * We recommend no more than three cycles of mounting and removal of the AMT top cover base. Multiple cycles of mounting and removing the top cover can cause base fatigue over time and affect encoder performance.

STEP 6

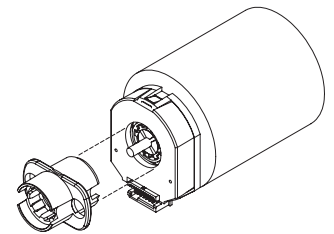

1. Make sure the snaps are fully engaged by pressing on the Hub with the reverse side of Tool C.
2. When assembly is finished, the Shaft Adaptor, Sleeve and Rotor Hub should all be flush with the Motor Shaft rotating freely.

APPLICATION NOTES

SERIAL INTERFACE

The AMT11 series encoder is designed to operate with a serial UART interface. This interface allows the encoder to be configured and programmed by the AMT Viewpoint™ application. Along with programming, the AMT Viewpoint™ application uses the serial interface for diagnostics and index alignment. Below are instructions on how to use the serial interface for position zeroing.

Table 1
Serial Commands

| Command | Action | Use |
|---------|---|--|
| 0 | This command sends an ascii '0' (hex value 0x30). | This zeros the encoder and sets the index at the current angular position. This position is stored in non-volatile memory and will remain present until a zero command is set again or encoder is reprogrammed via AMT Viewpoint™. |
| Q | This command sends an ascii 'Q' (hex value 0x51). | This command restarts the encoder as if it were power cycled. |

Table 2
Serial Pins

| Pin | Description | Connection |
|---------|--|---|
| TX_ENC+ | This is the pin that the encoder transmits serial data on. | Connect this pin to the receiver input of your serial/UART interface. |
| RX_ENC+ | This is the pin that the encoder receives serial commands on. | Connect this pin to your serial/UART interface transmitter output. |
| MCLR B | This pin is used to force the encoder into reset for reprogramming via the AMT Viewpoint™ application. | Connection of this pin is not required for the above serial commands. |

The serial interface operates at 115200 baud with 8 data bits, no parity, and 1 stop bit, and 1 start bit. This is the standard UART protocol. Data lines TX_ENC+ and RX_ENC+ are high when inactive.

Figure 2
Serial Timing Diagram

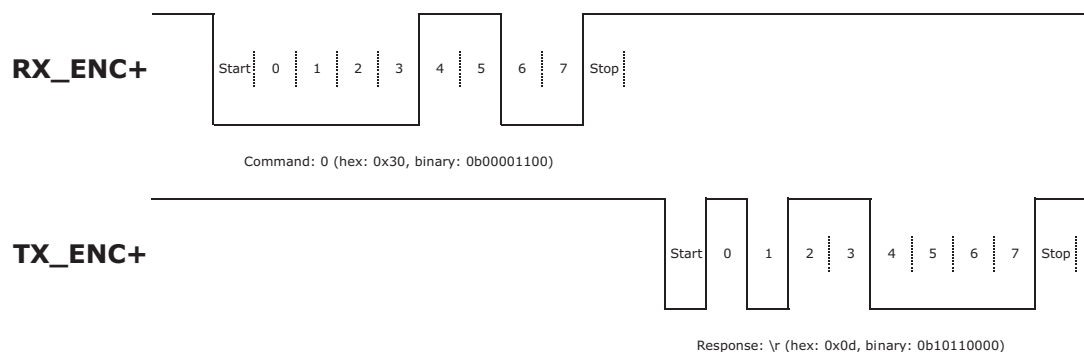

REVISION HISTORY

| rev. | description | date |
|------|--|------------|
| 1.0 | initial release | 04/30/2014 |
| 1.01 | updated datasheet | 06/24/2014 |
| 1.02 | updated datasheet | 10/13/2015 |
| 1.03 | added 360 & 2500 PPR resolutions, increased operating temperature to 125°C | 12/18/2017 |
| 1.04 | changed outer mounting holes to be oblong on wide base version | 10/10/2018 |
| 1.05 | brand update | 11/21/2019 |
| 1.06 | updated quadrature duty cycle details | 10/08/2020 |
| 1.07 | added motor shaft tolerance details, updated start-up details | 09/10/2021 |
| 1.08 | logo, datasheet style update | 08/05/2022 |

The revision history provided is for informational purposes only and is believed to be accurate.



CUI Devices offers a one (1) year limited warranty. Complete warranty information is listed on our website.

CUI Devices reserves the right to make changes to the product at any time without notice. Information provided by CUI Devices is believed to be accurate and reliable. However, no responsibility is assumed by CUI Devices for its use, nor for any infringements of patents or other rights of third parties which may result from its use.

CUI Devices products are not authorized or warranted for use as critical components in equipment that requires an extremely high level of reliability. A critical component is any component of a life support device or system whose failure to perform can be reasonably expected to cause the failure of the life support device or system, or to affect its safety or effectiveness.

cuidevices.com