

High Luminous Efficacy
RGBW LED Emitter

LZ4-00MD00



Key Features

- High Luminous Efficacy 10W RGBW LED
- Individually addressable Red, Green, Blue and Daylight White die
- Electrically neutral thermal path
- Ultra-small foot print – 7.0mm x 7.0mm
- Surface mount ceramic package with integrated glass lens
- Very low Thermal Resistance (1.1°C/W)
- Very high Luminous Flux density
- JEDEC Level 1 for Moisture Sensitivity Level
- Autoclave compliant (JEDEC JESD22-A102-C)
- Lead (Pb) free and RoHS compliant
- Reflow solderable (up to 6 cycles)
- Emitter available on Standard MCPCB (optional)

Typical Applications

- Architectural Lighting
- Retail Spot and Display Lighting
- Stage and Studio Lighting
- Hospitality Lighting
- Museum Lighting
- Video Walls and Full Color Displays

Description

The LZ4-00MD00 RGBW LED emitter contains one red, green, blue and daylight white LED die which provides 10W power in an extremely small package. With a 7.0mm x 7.0mm ultra-small footprint, this package provides exceptional luminous flux density. LED Engin's RGBW LED offers ultimate design flexibility with individually addressable die. The LZ4-00MD00 is capable of producing a continuous spectrum of white light plus millions of colors. The patented design has unparalleled thermal and optical performance. The high quality materials used in the package are chosen to optimize light output and minimize stresses which results in monumental reliability and lumen maintenance. The robust product design thrives in outdoor applications with high ambient temperatures and high humidity.

Part number options

Base part number

| Part number | Description |
|-----------------|--|
| LZ4-00MD00-xxxx | LZ4 emitter |
| LZ4-20MD00-xxxx | LZ4 emitter on Standard Star 4 channel MCPCB |

Bin kit option codes

| MD, Red-Green-Blue-White (5000K – 6500K) | | | |
|--|--------------|------------------------------|---|
| Kit number suffix | Min flux Bin | Color Bin Ranges | Description |
| 0000 | 09R | R2 – R2 | Red, full distribution flux; full distribution wavelength |
| | 12G | G2 – G3 | Green, full distribution flux; full distribution wavelength |
| | 01B | B01 – B02 | Blue, full distribution flux; full distribution wavelength |
| | 01W | 0bd, 0uy, 1bd, 1uy, 2vx, 2bd | White full distribution flux and CCT |

Daylight White Chromaticity Groups



Standard Chromaticity Groups plotted on excerpt from the CIE 1931 (2°) x-y Chromaticity Diagram. Coordinates are listed below in Table 5.

Cool White Bin Coordinates

| Bin Code | CIE _x | CIE _y | Bin Code | CIE _x | CIE _y | Bin Code | CIE _x | CIE _y |
|----------|------------------|------------------|----------|------------------|------------------|----------|------------------|------------------|
| OBD | 0.295 | 0.297 | 1BD | 0.3068 | 0.3113 | 2VX | 0.3207 | 0.3462 |
| | 0.2895 | 0.3135 | | 0.3028 | 0.3304 | | 0.3196 | 0.3602 |
| | 0.3028 | 0.3304 | | 0.3205 | 0.3481 | | 0.3381 | 0.3762 |
| | 0.3068 | 0.3113 | | 0.3221 | 0.3261 | | 0.3376 | 0.3616 |
| | 0.295 | 0.297 | | 0.3068 | 0.3113 | | 0.3207 | 0.3462 |
| OUY | 0.298 | 0.288 | 1UY | 0.3093 | 0.2993 | 2BD | 0.3222 | 0.3243 |
| | 0.295 | 0.297 | | 0.3068 | 0.3113 | | 0.3207 | 0.3462 |
| | 0.3068 | 0.3113 | | 0.3221 | 0.3261 | | 0.3376 | 0.3616 |
| | 0.3093 | 0.2993 | | 0.3231 | 0.312 | | 0.3366 | 0.3369 |
| | 0.298 | 0.288 | | 0.3093 | 0.2993 | | 0.3222 | 0.3243 |

Luminous Flux Bins

Table 1:

| Bin Code | Minimum Luminous Flux (Φ_v) @ $I_f = 700\text{mA}$ ^[1,2] (lm) | | | | Maximum Luminous Flux (Φ_v) @ $I_f = 700\text{mA}$ ^[1,2] (lm) | | | |
|----------|--|-------|------|-------|--|-------|------|-------|
| | Red | Green | Blue | White | Red | Green | Blue | White |
| | 09R | 90 | | | | 140 | | |
| 12G | | 125 | | | | 195 | | |
| 01B | | | 17 | | | | 27 | |
| 02B | | | 27 | | | | 43 | |
| 01W | | | | 155 | | | | 225 |

Notes for Table 1:

1. Luminous flux performance guaranteed within published operating conditions. LED Engin maintains a tolerance of $\pm 10\%$ on flux measurements.
2. Future products will have even higher levels of radiant flux performance. Contact LED Engin Sales for updated information.

Dominant Wavelength Bins

Table 2:

| Bin Code | Minimum Dominant Wavelength (λ_D) @ $I_f = 700\text{mA}$ ^[1] (nm) | | | Maximum Dominant Wavelength (λ_D) @ $I_f = 700\text{mA}$ ^[1] (nm) | | |
|----------|---|-------|------|---|-------|------|
| | Red | Green | Blue | Red | Green | Blue |
| | R2 | 618 | | | 630 | |
| G2 | | 520 | | | 525 | |
| G3 | | 525 | | | 530 | |
| B01 | | | 452 | | | 457 |
| B02 | | | 457 | | | 462 |

Notes for Table 2:

1. LED Engin maintains a tolerance of $\pm 1.0\text{nm}$ on dominant wavelength measurements.

Forward Voltage Bin

Table 3:

| Bin Code | Minimum Forward Voltage (V_f) @ $I_f = 700\text{mA}$ ^[1] (V) | | | | Maximum Forward Voltage (V_f) @ $I_f = 700\text{mA}$ ^[1] (V) | | | |
|----------|--|-------|------|-------|--|-------|------|-------|
| | Red | Green | Blue | White | Red | Green | Blue | White |
| | 0 | 2.10 | 3.20 | 3.20 | 3.20 | 3.20 | 4.20 | 4.00 |

Notes for Table 3:

1. LED Engin maintains a tolerance of $\pm 0.04\text{V}$ on forward voltage measurements.

Absolute Maximum Ratings

Table 4:

| Parameter | Symbol | Value | Unit |
|--|-----------|--|------|
| DC Forward Current $T_i = 150C$ | I_F | 1000 | mA |
| DC Forward Current ^[1] $T_i = 130C$ | I_F | 1200 | mA |
| Peak Pulsed Forward Current ^[2] | I_{FP} | 1500 | mA |
| Reverse Voltage | V_R | See Note 3 | V |
| Storage Temperature | T_{std} | -40 ~ +150 | °C |
| Junction Temperature | T_J | 150 | °C |
| Soldering Temperature ^[4] | T_{sol} | 260 | °C |
| Allowable Reflow Cycles | | 6 | |
| Autoclave Conditions ^[5] | | 121°C at 2 ATM, 100% RH for 168 hours | |
| ESD Sensitivity ^[6] | | > 8,000 V HBM Class 3B JESD22-A114-D | |

Notes for Table 4:

- Maximum DC forward current is determined by the overall thermal resistance and ambient temperature. Follow the curves in Figure 12 for current derating. Max current for continuous operation is 1.0A
- Pulse forward current conditions: Pulse Width ≤ 10 msec and Duty Cycle $\leq 10\%$.
- LEDs are not designed to be reversing biased.
- Solder conditions per JEDEC 020D. See Reflow Soldering Profile Figure 4.
- Autoclave Conditions per JEDEC JESD22-A102-C.
- LED Engin recommends taking reasonable precautions towards possible ESD damages and handling the emitter in an electrostatic protected area (EPA). An EPA may be adequately protected by ESD controls as outlined in ANSI/ESD S6.1.

Optical Characteristics @ $T_c = 25^\circ C$

Table 5:

| Parameter | Symbol | Typical | | | | Unit |
|-------------------------------------|-------------------------|---------|-------|---------------------|-------|---------|
| | | Red | Green | Blue ^[1] | White | |
| Luminous Flux (@ $I_F = 700$ mA) | Φ_V | 115 | 155 | 30 | 170 | lm |
| Luminous Flux (@ $I_F = 1000$ mA) | Φ_V | 160 | 200 | 40 | 222 | lm |
| Dominant Wavelength | | 623 | 523 | 460 | | |
| Correlated Color Temperature | CCT | | | | 6500 | K |
| Color Rendering Index (CRI) | R_a | | | | 75 | |
| Viewing Angle ^[2] | $2\theta_{\frac{1}{2}}$ | | 95 | | | |
| Total Included Angle ^[3] | $\theta_{0.9}$ | | 115 | | | Degrees |

Notes for Table 5:

- When operating the Blue LED, observe IEC 60825-1 class 2 rating. Do not stare into the beam.
- Viewing Angle is the off axis angle from emitter centerline where the luminous intensity is $\frac{1}{2}$ of the peak value.
- Total Included Angle is the total angle that includes 90% of the total luminous flux.

Electrical Characteristics @ $T_c = 25^\circ C$

Table 6:

| Parameter | Symbol | Typical | | | | Unit |
|--|---------------------------|---------|-------|------|-------|-------|
| | | Red | Green | Blue | White | |
| Forward Voltage (@ $I_F = 700$ mA) | V_F | 2.2 | 3.35 | 3.2 | 3.2 | V |
| Temperature Coefficient of Forward Voltage | $\Delta V_F / \Delta T_J$ | -1.9 | -2.9 | -3.0 | -3.0 | mV/°C |
| Thermal Resistance (Junction to Case) | $R\theta_{J-C}$ | | 1.1 | | | °C/W |

IPC/JEDEC Moisture Sensitivity Level

Table 7 - IPC/JEDEC J-STD-20D.1 MSL Classification:

| Level | Floor Life | | Soak Requirements | | | |
|-------|------------|-------------------|-------------------|-----------------|------------|------------|
| | Time | Conditions | Standard | Accelerated | Time (hrs) | Conditions |
| 1 | Unlimited | ≤ 30°C/ 85% RH | 168 +5/-0 | 85°C/ 85% RH | n/a | n/a |

Notes for Table 7:

- The standard soak time includes a default value of 24 hours for semiconductor manufacturer's exposure time (MET) between bake and bag and includes the maximum time allowed out of the bag at the distributor's facility.

Average Lumen Maintenance Projections

Lumen maintenance generally describes the ability of a lamp to retain its output over time. The useful lifetime for solid state lighting devices (Power LEDs) is also defined as Lumen Maintenance, with the percentage of the original light output remaining at a defined time period.

Based on long-term WHTOL testing, LED Engin projects that the LZ Series will deliver, on average, 70% Lumen Maintenance at 65,000 hours of operation at a forward current of 700 mA. This projection is based on constant current operation with junction temperature maintained at or below 125°C.

Mechanical Dimensions (mm)

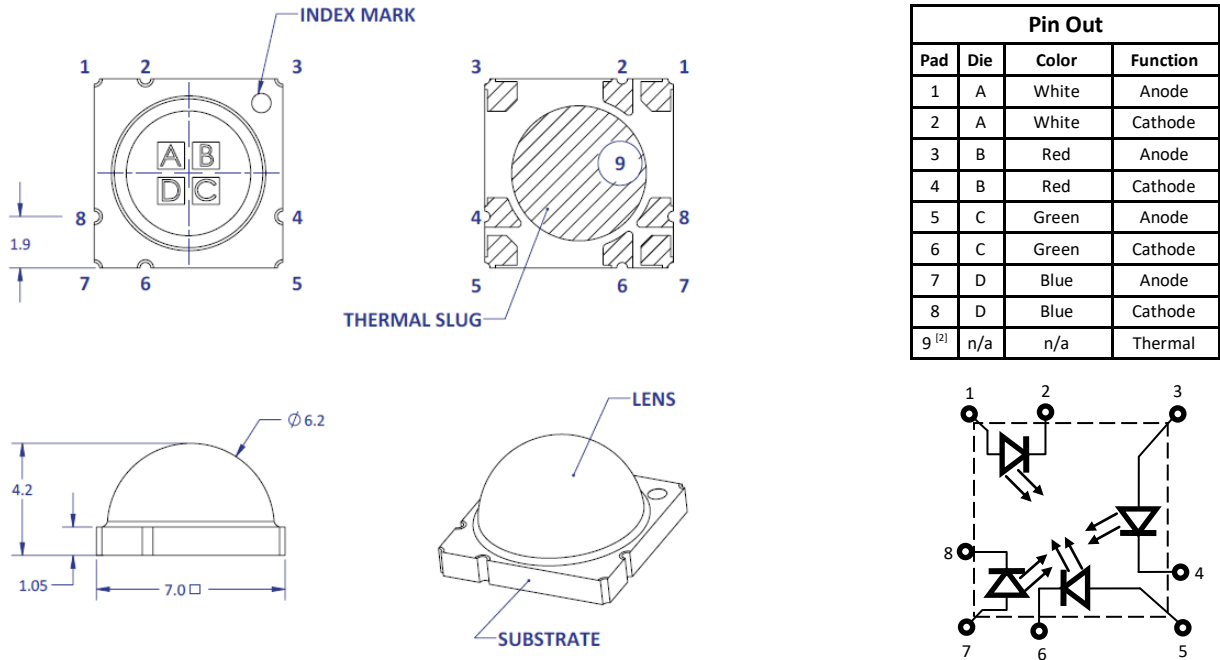

Figure 1: Package Outline Drawing.

Notes for Figure 1:

1. Unless otherwise noted, the tolerance = ± 0.20 mm.
2. Thermal contact, Pad 9, is electrically neutral.

Recommended Solder Pad Layout (mm)

Non-pedestal MCPCB Design

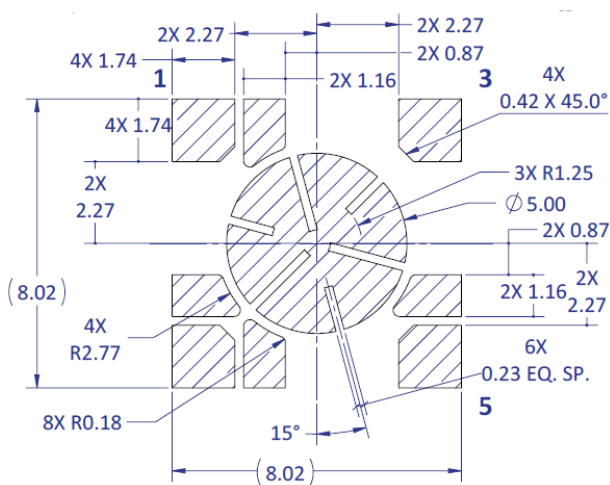

Pedestal MCPCB Design

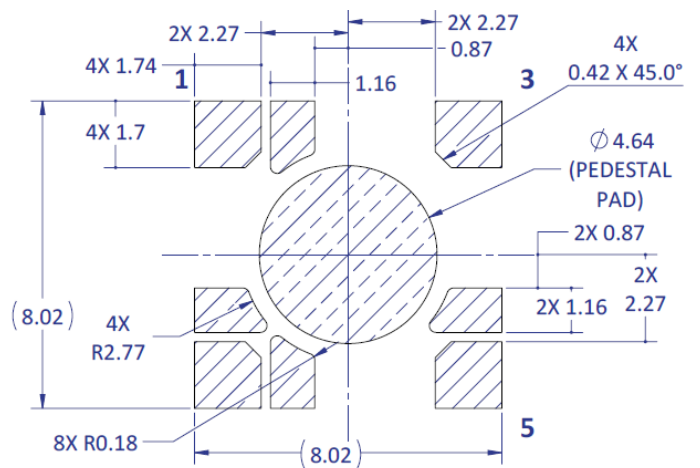

Figure 2a: Recommended solder pad layout for anode, cathode, and thermal pad for non-pedestal and pedestal design

Note for Figure 2a:

1. Unless otherwise noted, the tolerance = ± 0.20 mm.
2. Pedestal MCPCB allows the emitter thermal slug to be soldered directly to the metal core of the MCPCB. Such MCPCB eliminate the high thermal resistance dielectric layer that standard MCPCB technologies use in between the emitter thermal slug and the metal core of the MCPCB, thus lowering the overall system thermal resistance.
3. LED Engin recommends x-ray sample monitoring for solder voids underneath the emitter thermal slug. The total area covered by solder voids should be less than 20% of the total emitter thermal slug area. Excessive solder voids will increase the emitter to MCPCB thermal resistance and may lead to higher failure rates due to thermal over stress.

Recommended Solder Mask Layout (mm)



Figure 2b: Recommended solder mask opening for anode, cathode, and thermal pad for non-pedestal and pedestal design

Note for Figure 2b:

1. Unless otherwise noted, the tolerance = ± 0.20 mm.

Recommended 8 mil Stencil Apertures Layout (mm)

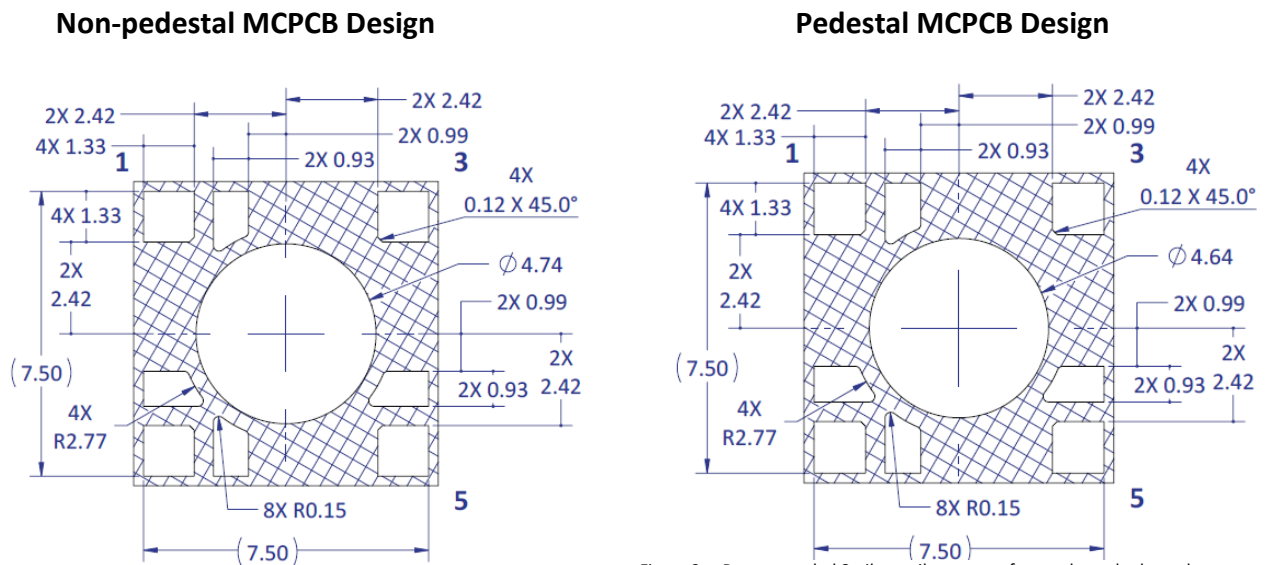

Figure 2c: Recommended 8mil stencil apertures for anode, cathode, and thermal pad for non-pedestal and pedestal design

Note for Figure 2c:

1. Unless otherwise noted, the tolerance = ± 0.20 mm.

Reflow Soldering Profile

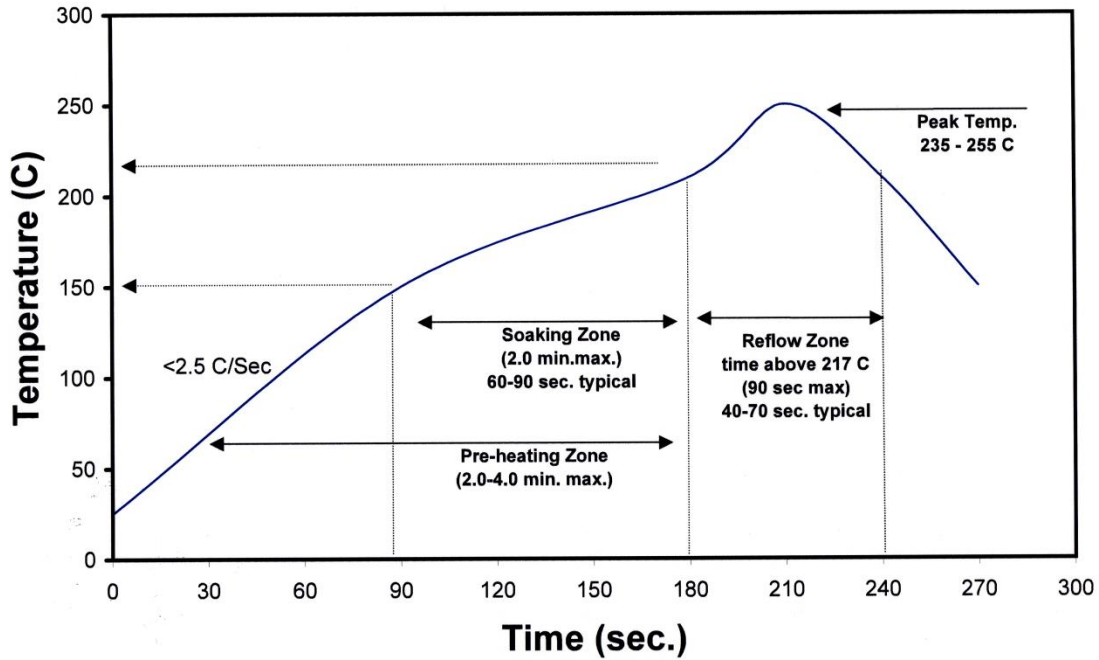

Figure 3: Reflow soldering profile for lead free soldering.

Typical Radiation Pattern

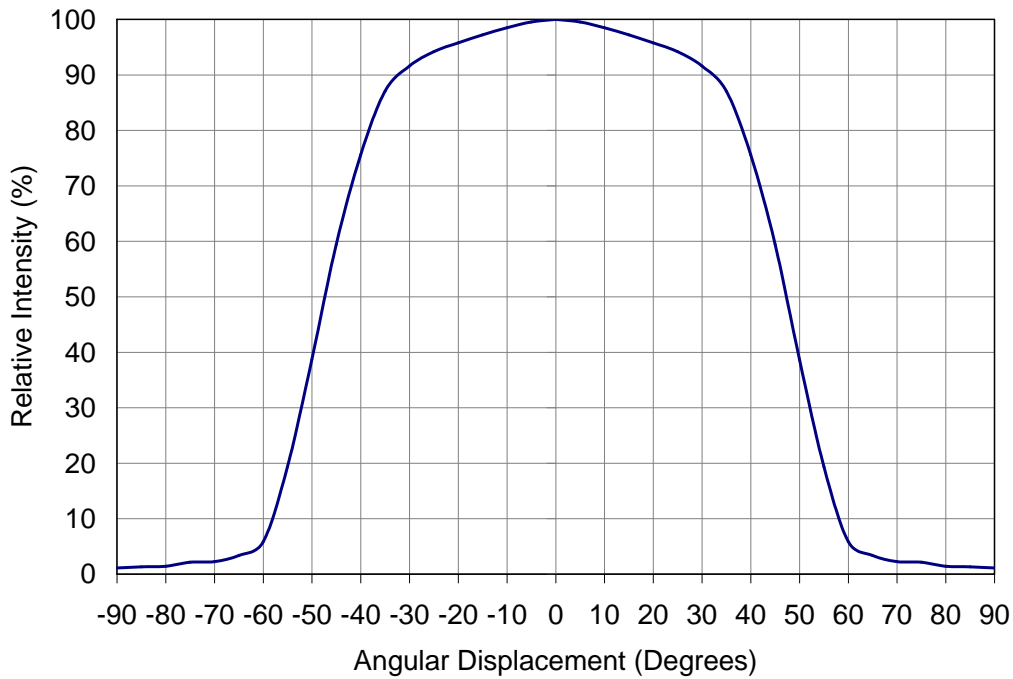

Figure 4: Typical representative spatial radiation pattern.

Typical Relative Spectral Power Distribution

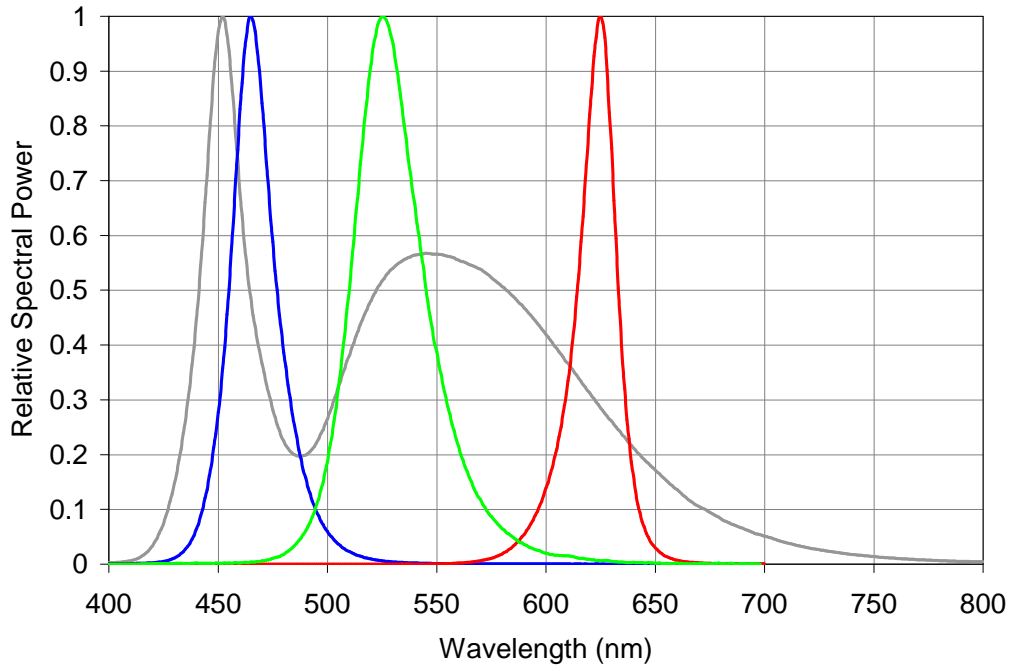

Figure 5: Typical relative spectral power vs. wavelength @ $T_c = 25^\circ\text{C}$.

Typical Dominant Wavelength Shift

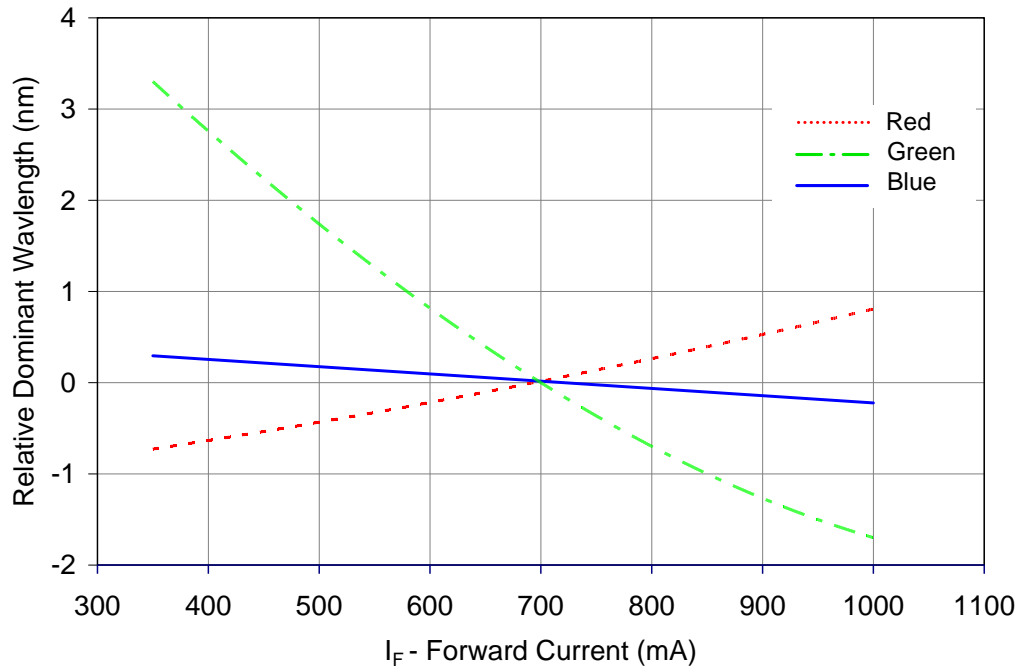

Figure 6: Typical dominant wavelength shift vs. forward current @ $T_c = 25^\circ\text{C}$.

Dominant Wavelength Shift over Temperature

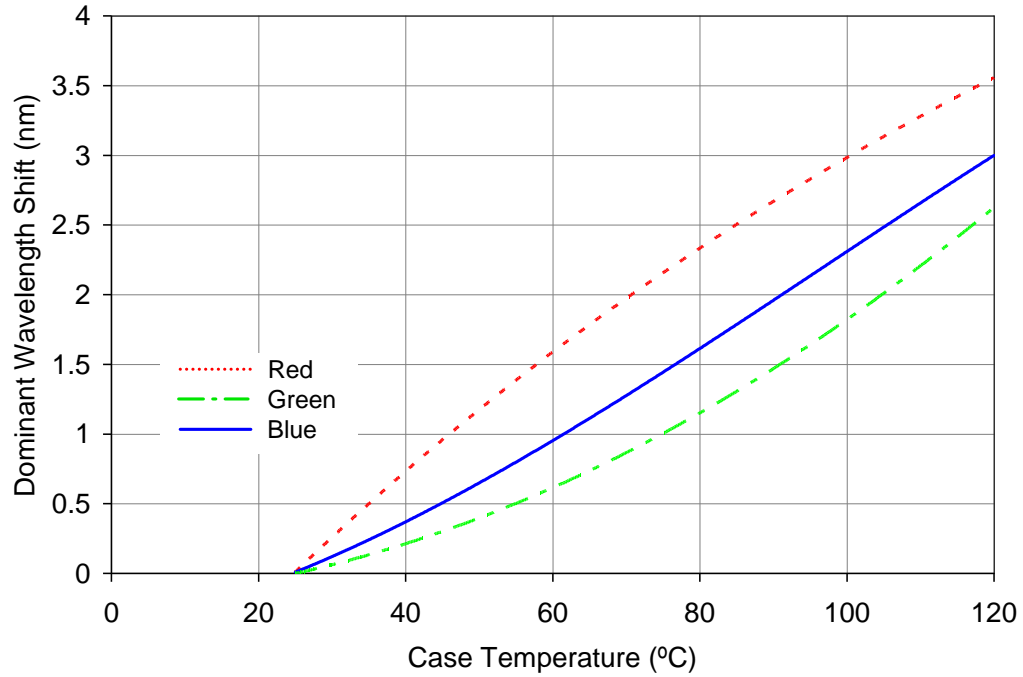

Figure 7: Typical dominant wavelength shift vs. case temperature.

Typical Relative Light Output



Figure 8: Typical relative light output vs. forward current @ $T_C = 25^\circ\text{C}$.

Typical Relative Light Output over Temperature



Figure 9: Typical relative light output vs. case temperature.

Typical Forward Current Characteristics



Figure 10: Typical forward current vs. forward voltage @ T_c = 25°C.

Current De-rating

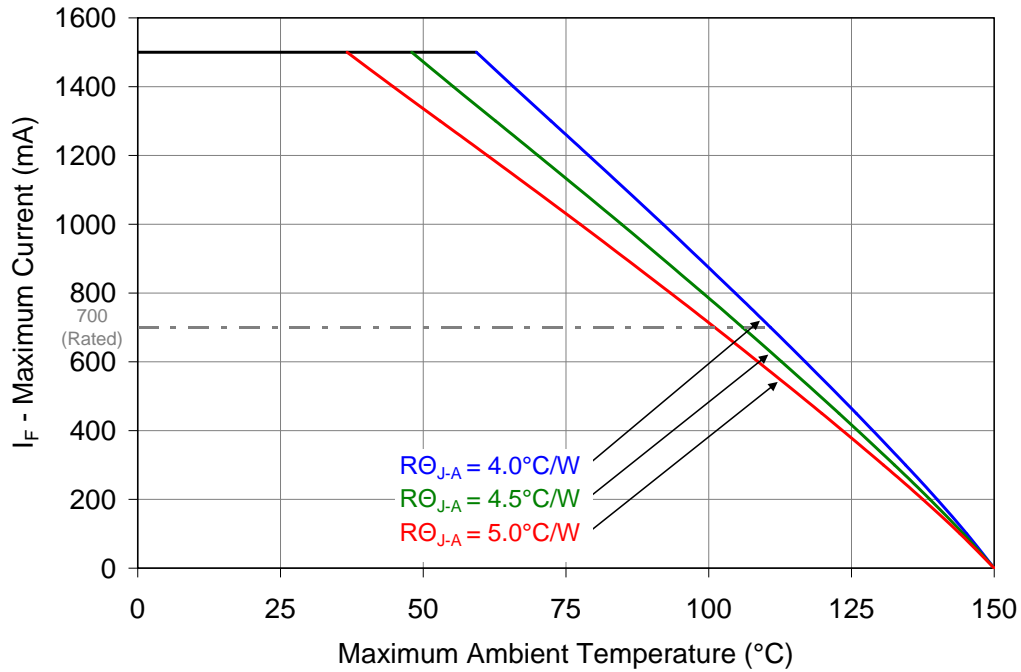

Figure 11: Maximum forward current vs. ambient temperature based on $T_{J(\text{MAX})} = 150^{\circ}\text{C}$.

Notes for Figure 11:

1. Maximum current assumes that all four LED dice are operating concurrently at the same current.
2. $R\theta_{J-C}$ [Junction to Case Thermal Resistance] for the LZ4-00MD00 is typically 1.1°C/W .
3. $R\theta_{J-A}$ [Junction to Ambient Thermal Resistance] = $R\theta_{J-C} + R\theta_{C-A}$ [Case to Ambient Thermal Resistance].

Emitter Tape and Reel Specifications (mm)



Figure 12: Emitter carrier tape specifications (mm).

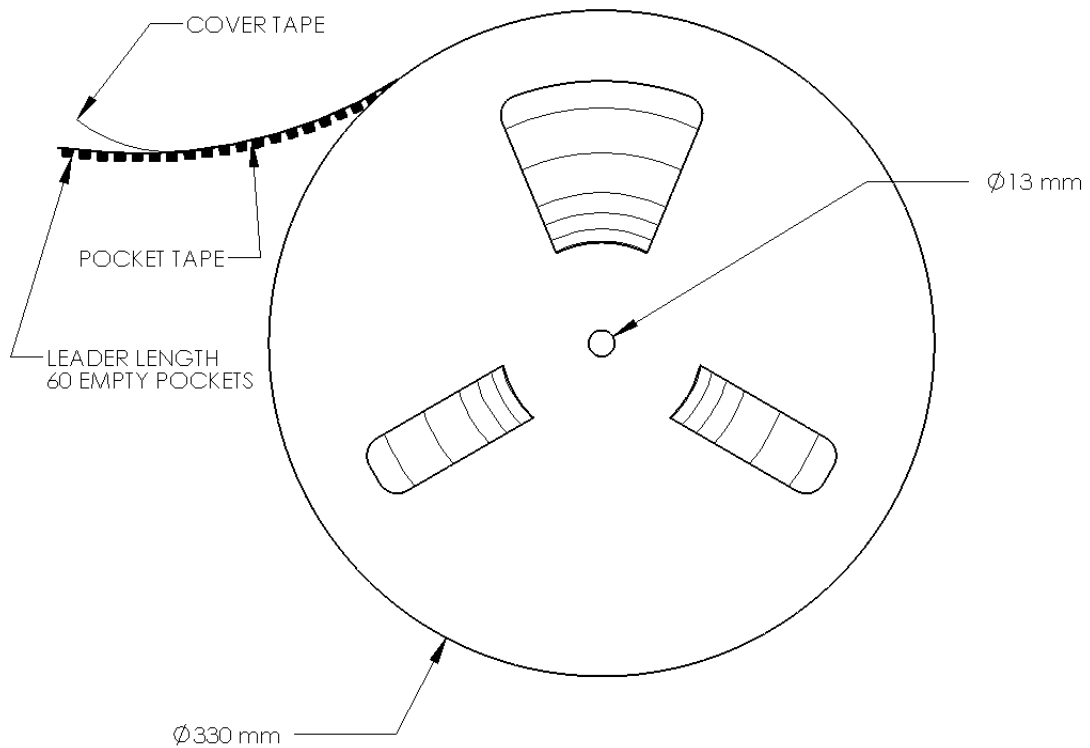

Figure 13: Emitter reel specifications (mm).

LZ4 MCPCB Family

| Part number | Type of MCPCB | Diameter (mm) | Emitter + MCPCB Thermal Resistance (°C/W) | Typical V_f (V) | Typical I_f (mA) |
|-------------|---------------|---------------|---|-------------------|--------------------|
| LZ4-2xxxxxx | 4-channel | 19.9 | 1.1 + 1.1 = 2.2 | 2.2 – 3.4 | 700 |

Mechanical Mounting of MCPCB

- MCPCB bending should be avoided as it will cause mechanical stress on the emitter, which could lead to substrate cracking and subsequently LED dies cracking.
- To avoid MCPCB bending:
 - Special attention needs to be paid to the flatness of the heat sink surface and the torque on the screws.
 - Care must be taken when securing the board to the heat sink. This can be done by tightening three M3 screws (or #4-40) in steps and not all the way through at once. Using fewer than three screws will increase the likelihood of board bending.
 - It is recommended to always use plastics washers in combinations with the three screws.
 - If non-taped holes are used with self-tapping screws, it is advised to back out the screws slightly after tightening (with controlled torque) and then re-tighten the screws again.

Thermal interface material

- To properly transfer heat from LED emitter to heat sink, a thermally conductive material is required when mounting the MCPCB on to the heat sink.
- There are several varieties of such material: thermal paste, thermal pads, phase change materials and thermal epoxies. An example of such material is Electrolube EHTC.
- It is critical to verify the material's thermal resistance to be sufficient for the selected emitter and its operating conditions.

Wire soldering

- To ease soldering wire to MCPCB process, it is advised to preheat the MCPCB on a hot plate of 125-150°C. Subsequently, apply the solder and additional heat from the solder iron will initiate a good solder reflow. It is recommended to use a solder iron of more than 60W.
- It is advised to use lead-free, no-clean solder. For example: SN-96.5 AG-3.0 CU 0.5 #58/275 from Kester (pn: 24-7068-7601)

LZ4-2xxxxx

4 channel, Standard Star MCPCB (4x1) Dimensions (mm)

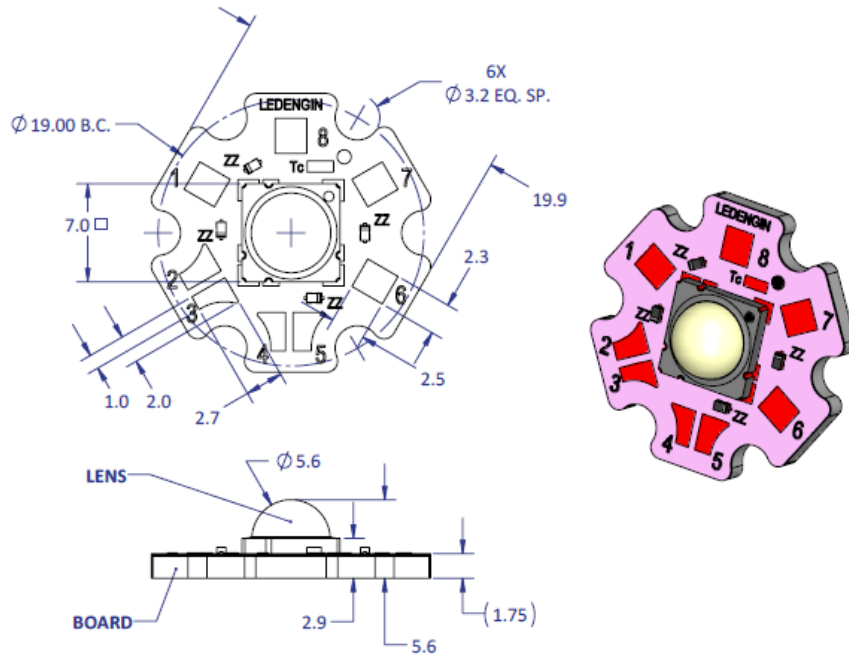

Notes:

- Unless otherwise noted, the tolerance = ± 0.2 mm.
- Slots in MCPCB are for M3 or #4-40 mounting screws.
- LED Engin recommends plastic washers to electrically insulate screws from solder pads and electrical traces.
- LED Engin recommends using thermal interface material when attaching the MCPCB to a heatsink.
- The thermal resistance of the MCPCB is: $R_{\theta C-B}$ 1.1°C/W

Components used

MCPCB: HT04503 (Bergquist)
ESD chips: BZT52C5-C10 (NPX, for 1 LED die)

| Pad layout | | | |
|------------|-----------|------------|-----------|
| Ch. | MCPCB Pad | String/die | Function |
| 1 | 1 | 1/A | Anode + |
| | 8 | | Cathode - |
| 2 | 7 | 2/B | Anode + |
| | 6 | | Cathode - |
| 3 | 5 | 3/C | Anode + |
| | 4 | | Cathode - |
| 4 | 3 | 4/D | Anode + |
| | 2 | | Cathode - |

About LED Engin

LED Engin, an OSRAM business based in California's Silicon Valley, develops, manufactures, and sells advanced LED emitters, optics and light engines to create uncompromised lighting experiences for a wide range of entertainment, architectural, general lighting and specialty applications. LuxiGen™ multi-die emitter and secondary lens combinations reliably deliver industry-leading flux density, upwards of 5000 quality lumens to a target, in a wide spectrum of colors including whites, tunable whites, multi-color and UV LEDs in a unique patented compact ceramic package. Our LuxiTune™ series of tunable white lighting modules leverage our LuxiGen emitters and lenses to deliver quality, control, freedom and high density tunable white light solutions for a broad range of new recessed and downlighting applications. The small size, yet remarkably powerful beam output and superior in-source color mixing, allows for a previously unobtainable freedom of design wherever high-flux density, directional light is required. LED Engin is committed to providing products that conserve natural resources and reduce greenhouse emissions; and reserves the right to make changes to improve performance without notice.

For more information, please contact LEDE-Sales@osram.com or +1 408 922-7200.