

Product Specification

NHD-24064WG-AYYH-VZ#

Graphic Liquid Crystal Display Module

| | |
|---------------|--|
| NHD- | Newhaven Display |
| 24064- | 240 x 64 Pixels |
| WG- | Display Type: Graphic |
| A- | Model |
| Y- | Yellow/Green LED Backlight |
| Y- | STN (+), Yellow/Green |
| H- | Transflective, 6:00 Optimal View, Wide Temperature |
| VZ#- | Built-in Negative Voltage Supply |

Table of Contents

| | |
|----------------------------------|----|
| Document Revision History | 2 |
| Functions and Features | 2 |
| Mechanical Drawing | 3 |
| Pin Description | 4 |
| Electrical Characteristics | 5 |
| Optical Characteristics | 5 |
| Controller Information | 5 |
| Table of Commands | 6 |
| Timing Characteristics | 7 |
| Built-in Font Table | 8 |
| Example Code | 9 |
| Quality Information | 10 |

Additional Resources

- **Support Forum:** <http://www.nhdforum.newhavendisplay.com>
- **Github:** <https://github.com/newhavendisplay>
- **Example Code:** https://www.newhavendisplay.com/example_code.html
- **Knowledge Center:** https://www.newhavendisplay.com/knowledge_center.html
- **Quality Center:** https://www.newhavendisplay.com/quality_center.html
- **Precautions for using LCDs/LCMs:** <https://www.newhavendisplay.com/specs/precautions.pdf>
- **Warranty / Terms & Conditions:** <https://www.newhavendisplay.com/terms.html>



Document Revision History

| Revision | Date | Description | Changed By |
|----------|----------|---|------------|
| 0 | 2/28/08 | Initial Release | - |
| 1 | 4/19/10 | User guide reformat | BE |
| 2 | 5/13/10 | Updated Backlight Current Min/Max- New Mechanical Drawing: Backlight Connector Cable is not on this display | MC |
| 3 | 5/14/10 | Mechanical drawing update | MP |
| 4 | 5/14/10 | Drawing update | MP |
| 5 | 11/16/10 | Pin description update | AK |
| 6 | 9/20/11 | Mechanical Drawing Updated | TJ |
| 7 | 5/16/12 | Optical characteristics updated | AK |
| 8 | 2/28/13 | Electrical characteristics updated | AK |
| 9 | 5/7/13 | Wiring diagram and font table updated. | JN |
| 10 | 8/21/17 | Mechanical, Electrical & Optical Characteristics Updated | SB |
| 11 | 8/23/19 | PCB Redesign | SB |
| 12 | 05/18/21 | Electrical, Optical & IC Updated | ZP |
| 13 | 08/23/21 | Updated Mechanical Drawing | ZP |

Functions and Features

- 240 x 64 pixels
- Built-in RA6963N1 controller
- +5.0V Power Supply
- 1/64 duty

Mechanical Drawing

| SYMBOL | REVISION | DATE |
|--------|----------|------|
| | | |

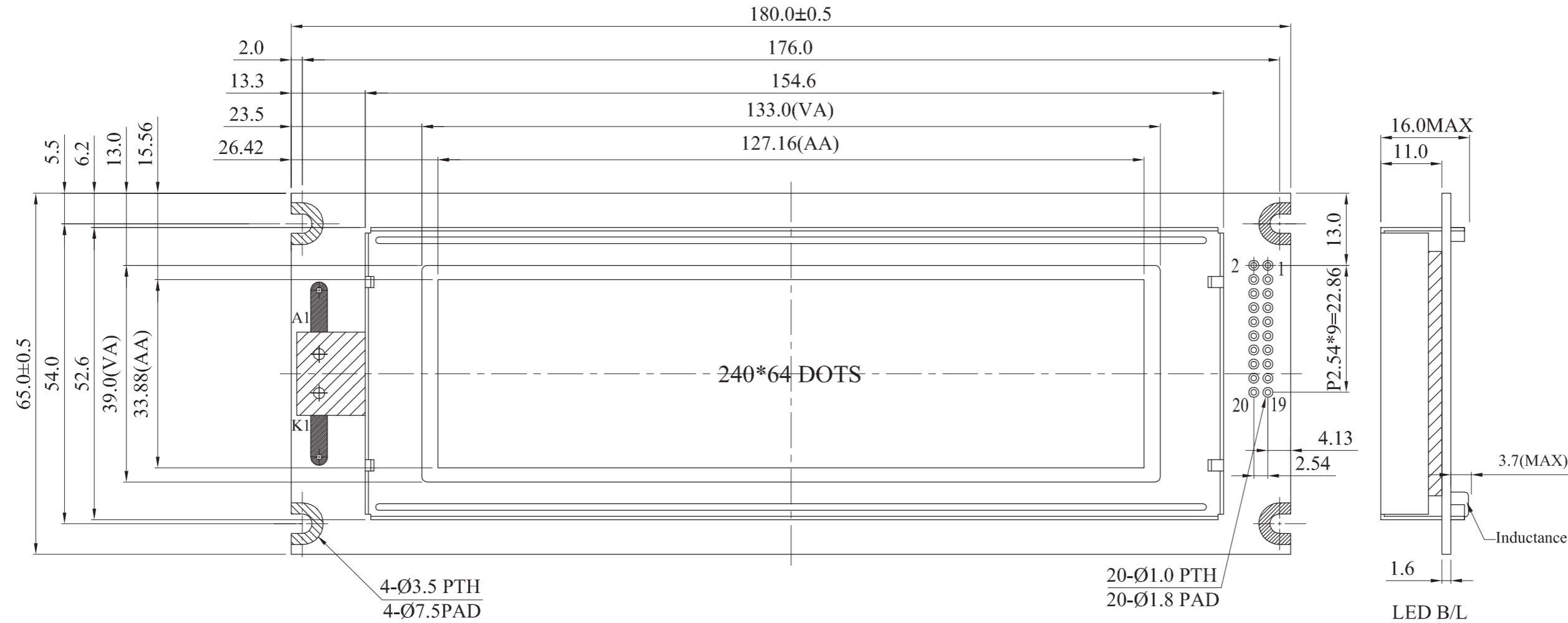

Pin Assignment

| PIN NO. | SYMBOL |
|---------|----------------------|
| 1 | FG |
| 2 | V _{SS} |
| 3 | V _{DD} |
| 4 | V ₀ |
| 5 | /WR |
| 6 | /RD |
| 7 | /CE |
| 8 | C/D |
| 9 | V _{EE} (NC) |
| 10 | /RESET |
| 11 | DB0 |
| 12 | DB1 |
| 13 | DB2 |
| 14 | DB3 |
| 15 | DB4 |
| 16 | DB5 |
| 17 | DB6 |
| 18 | DB7 |
| 19 | FS |
| 20 | NC(V _{EE}) |

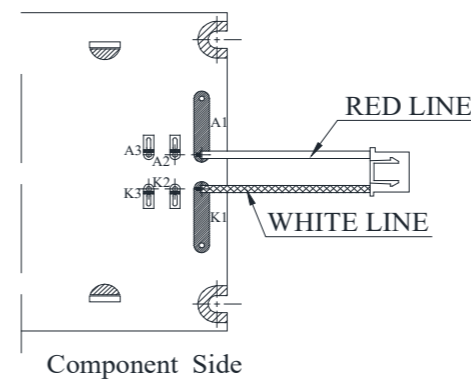
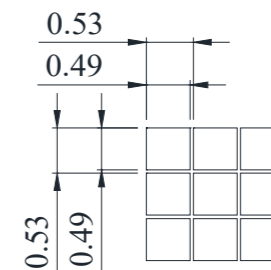
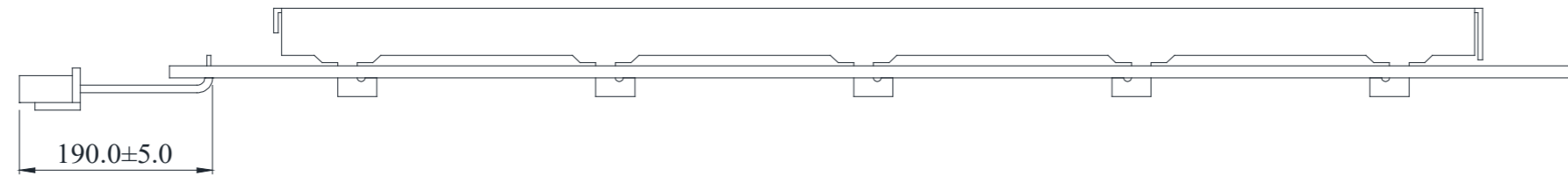

Notes:

1. Driver: 1/64 Duty, 1/9 Bias
2. Voltage: 5V V_{DD}, 12.5V V_{LCD}
3. Display Mode: STN Positive/ Yellow-Green / Transflective
4. Optimal View: 6:00
5. Backlight: Yellow-Green LED
6. Driver IC: RA6963N1

| | | |
|---|--|------------------------------|
| STANDARD TOLERANCE: (UNLESS OTHERWISE SPECIFIED) | | |
| LINEAR: ±0.3mm | DRAWING/PART NUMBER: NHD-24064WG-AYYH-VZ# | REVISION: 1A |
| UNLESS OTHERWISE SPECIFIED: - DIMENSIONS ARE IN MILLIMETERS - THIRD ANGLE PROJECTION | DRAWN BY: Z.Palrang | APPROVED BY: Z.Palrang |
| | DRAWN DATE: 08/23/2021 | APPROVED DATE: 08/23/2021 |
| | DO NOT SCALE DRAWING | |
| | SHEET 1 OF 1 | |
| THIS DRAWING IS SOLELY THE PROPERTY OF NEWHAVEN DISPLAY INTERNATIONAL, INC. THE INFORMATION IT CONTAINS IS NOT TO BE DISCLOSED, REPRODUCED OR COPIED IN WHOLE OR PART WITHOUT WRITTEN APPROVAL FROM NEWHAVEN DISPLAY. | | |

Pin Description and Wiring Diagram

| Pin No. | Symbol | External Connection | Function Description |
|---------|-----------------|---------------------|---|
| 1 | FGND | Power Supply | Frame Ground |
| 2 | V _{SS} | Power Supply | Ground |
| 3 | V _{DD} | Power Supply | Power supply for logic (+5.0V) |
| 4 | V ₀ | Adj. Power Supply | Power supply for contrast (approx. -7.5V) |
| 5 | /WR | MPU | Active LOW Write signal |
| 6 | /RD | MPU | Active LOW Read signal |
| 7 | /CE | MPU | Active LOW chip enable |
| 8 | C/D | MPU | Register Select signal C/D=0: DATA C/D=1: COMMAND |
| 9 | VEE | Power Supply | Negative voltage output (-10V) |
| 10 | /RST | MPU | Active LOW Reset signal |
| 11~18 | DB0~DB7 | MPU | 8-bit Bi-directional data bus |
| 19 | FS | MPU | Font Select: 1=6x8 fonts, 0=8x8 fonts |
| 20 | NC | - | No Connect |
| A | LED+ | Power Supply | Backlight Anode (4.2V) |
| K | LED- | Power Supply | Backlight Cathode (Ground) |

Recommended LCD connector: 2.54mm pitch pins

Backlight connector: --- **Mates with:** ---

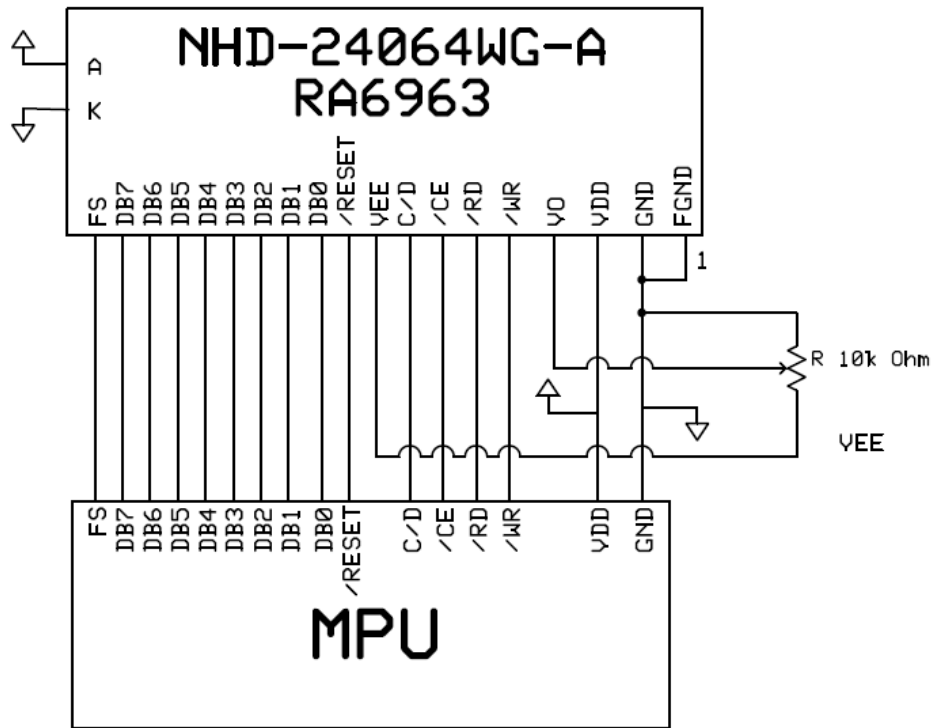

Electrical Characteristics

| Item | Symbol | Condition | Min. | Typ. | Max. | Unit |
|-----------------------------|------------------|--------------------------|-----------------------|---------|----------------------|------|
| Operating Temperature Range | T _{OP} | Absolute Max | -20 | - | +70 | °C |
| Storage Temperature Range | T _{ST} | Absolute Max | -30 | - | +80 | °C |
| Supply Voltage | V _{DD} | - | 4.5 | 5.0 | 5.5 | V |
| Supply Current | I _{DD} | V _{DD} = 5.0V | 8.2 | 16.5 | 33 | mA |
| Supply for LCD (contrast) | V _{LCD} | T _{OP} = 25°C | 12.1 | 12.5 | 12.9 | V |
| "H" Level input | V _{IH} | - | 0.8*V _{DD} | - | V _{DD} | V |
| "L" Level input | V _{IL} | - | V _{SS} | - | 0.15*V _{DD} | V |
| "H" Level output | V _{OH} | - | V _{DD} - 0.3 | - | V _{DD} | V |
| "L" Level output | V _{OL} | - | V _{SS} | - | 0.3 | V |
| Backlight Supply Current | I _{LED} | - | 528 | 660 | 792 | mA |
| Backlight Supply Voltage | V _{LED} | I _{LED} = 660mA | 4.0 | 4.2 | 4.4 | V |
| Lifetime* | - | T _{OP} = 25°C | - | 100,000 | - | Hrs. |

*The LED of the backlight is driven by current drain; drive voltage is for reference only. Drive voltage must be selected to ensure backlight current drain is below MAX level stated.

Optical Characteristics

| Item | | Symbol | Condition | Min. | Typ. | Max. | Unit |
|------------------------|--------|----------------|------------------------|------|------|------|------|
| Optimal Viewing Angles | Top | φY+ | CR ≥ 2 | 0 | - | 20 | ° |
| | Bottom | φY- | | 0 | - | 40 | ° |
| | Left | θX- | | 0 | - | 30 | ° |
| | Right | θX+ | | 0 | - | 30 | ° |
| Contrast Ratio | | CR | - | 2 | 3 | - | - |
| Response Time | Rise | T _R | T _{OP} = 25°C | - | 200 | 300 | ms |
| | Fall | T _F | | - | 250 | 350 | ms |

Controller Information

Built-in RA6963N1.

Please download specification at https://www.newhavendisplay.com/resources_dataFiles/datasheets/LCDs/RA6963.pdf



Table of Commands

| Command | Code | D1 | D2 | Function |
|------------------------------|----------|-------------|--------------|---------------------------------|
| Registers Setting | 00100001 | X address | Y address | Set cursor pointer |
| | 00100010 | Data | 00h | Set Offset Register |
| | 00100100 | Low address | High address | Set Address pointer |
| Set Control Word | 01000000 | Low address | High address | Set Text Home Address |
| | 01000001 | Columns | 00h | Set Text Area |
| | 01000010 | Low address | High address | Set Graphic Home Address |
| | 01000011 | Columns | 00h | Set Graphic Area |
| Mode Set | 1000X000 | -- | -- | OR mode |
| | 1000X001 | -- | -- | EXOR mode |
| | 1000X011 | -- | -- | AND mode |
| | 1000X100 | -- | -- | Text Attribute mode |
| | 10000XXX | -- | -- | Internal CG ROM mode |
| | 10001XXX | -- | -- | External CG RAM mode |
| Display Mode | 10010000 | -- | -- | Display off |
| | 1001XX10 | -- | -- | Cursor on, blink off |
| | 1001XX11 | -- | -- | Cursor on, blink on |
| | 100101XX | -- | -- | Text on, graphic off |
| | 100110XX | -- | -- | Text off, graphic on |
| | 100111XX | -- | -- | Text on, graphic on |
| Cursor Pattern Select | 10100000 | -- | -- | 1-line cursor |
| | 10100001 | -- | -- | 2-line cursor |
| | 10100010 | -- | -- | 3-line cursor |
| | 10100011 | -- | -- | 4-line cursor |
| | 10100100 | -- | -- | 5-line cursor |
| | 10100101 | -- | -- | 6-line cursor |
| | 10100110 | -- | -- | 7-line cursor |
| | 10100111 | -- | -- | 8-line cursor |
| Data auto Read/Write | 10110000 | -- | -- | Set Data Auto Write |
| | 10110001 | -- | -- | Set Data Auto Read |
| | 10110010 | -- | -- | Auto Reset |
| Data Read/Write | 11000000 | Data | -- | Data Write and Increment ADP |
| | 11000001 | -- | -- | Data Read and Increment ADP |
| | 11000010 | Data | -- | Data Write and Decrement ADP |
| | 11000011 | -- | -- | Data Read and Decrement ADP |
| | 11000100 | Data | -- | Data Write and Non-variable ADP |
| | 11000101 | -- | -- | Data Read and Non-variable ADP |
| Screen Peek | 11100000 | -- | -- | Screen Peek |
| Screen Copy | 11101000 | | | Screen Copy |
| Bit Set/Reset | 11110XXX | -- | -- | Bit Reset |
| | 11111XXX | -- | -- | Bit Set |
| | 1111X000 | -- | -- | Bit 0 (LSB) |
| | 1111X001 | -- | -- | Bit 1 |
| | 1111X010 | -- | -- | Bit 2 |
| | 1111X011 | -- | -- | Bit 3 |
| | 1111X100 | -- | -- | Bit 4 |
| | 1111X101 | -- | -- | Bit 5 |
| | 1111X110 | -- | -- | Bit 6 |
| | 1111X111 | -- | -- | Bit 7 (MSB) |

Timing Characteristics

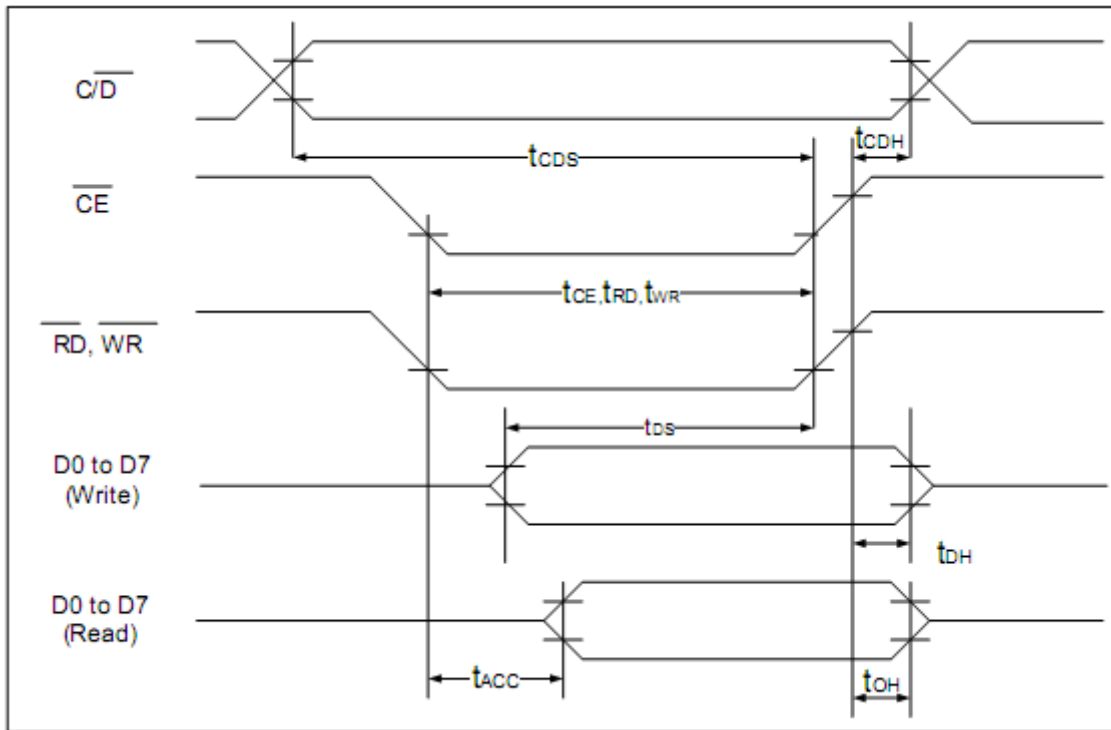

($V_{DD}=+5V\pm 5\%, GND=0V, T_a = -20$ to $+70^\circ C$)

| Item | Symbol | Test Conditions | Min. | Max. | Unit |
|---|--------------------------|-----------------|------|------|------|
| $\overline{C/D}$ Set Up Time | t_{CDS} | -- | 100 | -- | ns |
| $\overline{C/D}$ Hold Time | t_{CDH} | -- | 10 | -- | ns |
| $\overline{CE}, \overline{RD}, \overline{WR}$ Pulse Width | t_{CE}, t_{RD}, t_{WR} | -- | 80 | -- | ns |
| Data Set Up Time | t_{DS} | -- | 80 | -- | ns |
| Data Hold Time | t_{DH} | -- | 40 | -- | ns |
| Access Time | t_{ACC} | -- | -- | 150 | ns |
| Output Hold Time | t_{OH} | -- | 10 | 50 | ns |

Built-in Font Table

| LSB MSB | 0 | 1 | 2 | 3 | 4 | 5 | 6 | 7 | 8 | 9 | A | B | C | D | E | F |
|------------|---|---|---|---|----|---|---|---|---|---|---|---|---|---|---|---|
| 0 | | ! | " | # | \$ | % | & | ' | (|) | * | + | , | - | . | / |
| 1 | 0 | 1 | 2 | 3 | 4 | 5 | 6 | 7 | 8 | 9 | : | ; | < | = | > | ? |
| 2 | A | B | C | D | E | F | G | H | I | J | K | L | M | N | O | |
| 3 | P | Q | R | S | T | U | U | W | X | Y | Z | [| \ |] | ^ | _ |
| 4 | ` | a | b | c | d | e | f | g | h | i | j | k | l | m | n | o |
| 5 | p | q | r | s | t | u | v | w | x | y | z | { | | } | ~ | |
| 6 | Q | Ü | È | Å | ä | å | Ä | Q | È | È | È | ì | ì | ì | Ä | Ä |
| 7 | È | Æ | Æ | ö | ö | ö | Ü | Ü | Ü | Ü | Ø | Ø | £ | ¥ | ℞ | ƒ |

Example Program Code

```
void command(int A)
{
    P1 = A;
    ID = 1;           //Command
    CE = 0;
    WRT = 0;
    WRT = 1;
    CE = 1;
}

void data(int A)
{
    P1 = A;
    ID = 0;           //Data
    CE = 0;
    WRT = 0;
    WRT = 1;
    CE = 1;
}

void init()
{
    RST = 1;
    RDD = 1;
    F_S = 1;
    data(0x00);
    data(0x00);
    commnd(0x40);     //Set Text Home Address
    data(0x00);       //Low Address Columns
    data(0x40);       //High Address
    command(0x42);    //Set Graphic Home Address
    data(0x1E);       //Low Address Columns
    data(0x00);       //High Address
    command(0x41);    //Set Text Area
    data(0x1E);       //Low Address Columns
    data(0x00);       //High Address
    command(0x43);    //Set Graphic Areaa
    command(0x80);    //Mode Set to 'OR' mode
}
```



Quality Information

| Test Item | Content of Test | Test Condition | Note |
|---------------------------------------|---|---|------|
| High Temperature storage | Endurance test applying the high storage temperature for a long time. | +80°C, 200hrs | 2 |
| Low Temperature storage | Endurance test applying the low storage temperature for a long time. | -30°C, 200hrs | 1,2 |
| High Temperature Operation | Endurance test applying the electric stress (voltage & current) and the high thermal stress for a long time. | +70°C, 200hrs | 2 |
| Low Temperature Operation | Endurance test applying the electric stress (voltage & current) and the low thermal stress for a long time. | -20°C, 200hrs | 1,2 |
| High Temperature / Humidity Operation | Endurance test applying the electric stress (voltage & current) and the high thermal with high humidity stress for a long time. | +60°C, 90% RH, 96hrs | 1,2 |
| Thermal Shock resistance | Endurance test applying the electric stress (voltage & current) during a cycle of low and high thermal stress. | -20°C, 30min -> 25°C, 5min -> 70°C, 30min = 1 cycle 10 cycles | |
| Vibration test | Endurance test applying vibration to simulate transportation and use. | 10-55Hz, 1.5mm amplitude. 60 sec in each of 3 directions X,Y,Z For 15 minutes | 3 |
| Static electricity test | Endurance test applying electric static discharge. | Air: ±800V 150pF/330Ω, 5 Times | |
| | | Contact: ±600V 150pF/330Ω, 5 Times | |

Note 1: No condensation to be observed.

Note 2: Conducted after 4 hours of storage at 25°C, 0%RH.

Note 3: Test performed on product itself, not inside a container.