

ROHS

SPECIFICATIONS

Rated Current:1.5AMP
 Contact Resistance:20mΩ Max
 Withstand Voltage:400V AC/DC
 Insulation Resistance:800MΩ Min
 Operation Temperature:-40°c to +105°c
 Contact Material:Brass
 Contact Plating:Au Over Ni
 Insulator Material:Polyester(UL94V-0)
 Standard: PA6T
 Max.Processing Temp: 230°C for 30-60 seconds
 (260°C for 10 seconds)

Recommended P.C.B Layout(Top Side)
 (PCB BOARD TOLERANCE±0.05)

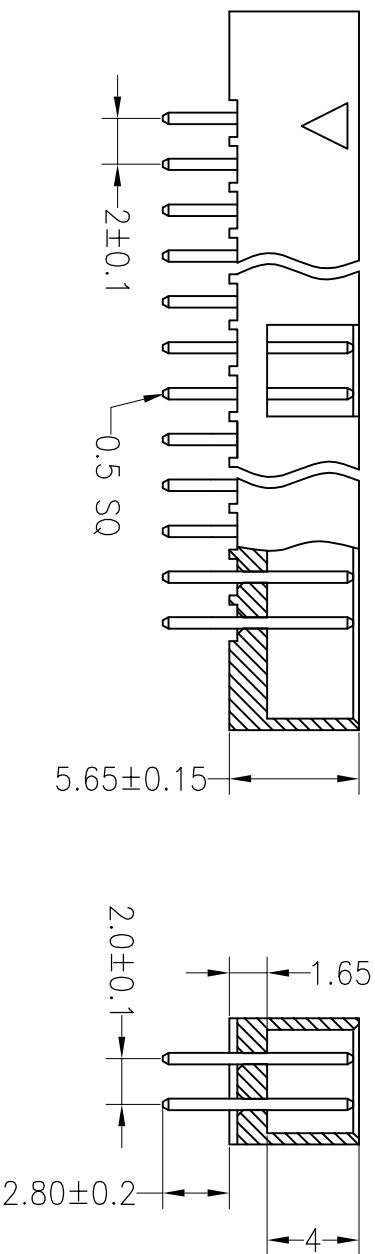
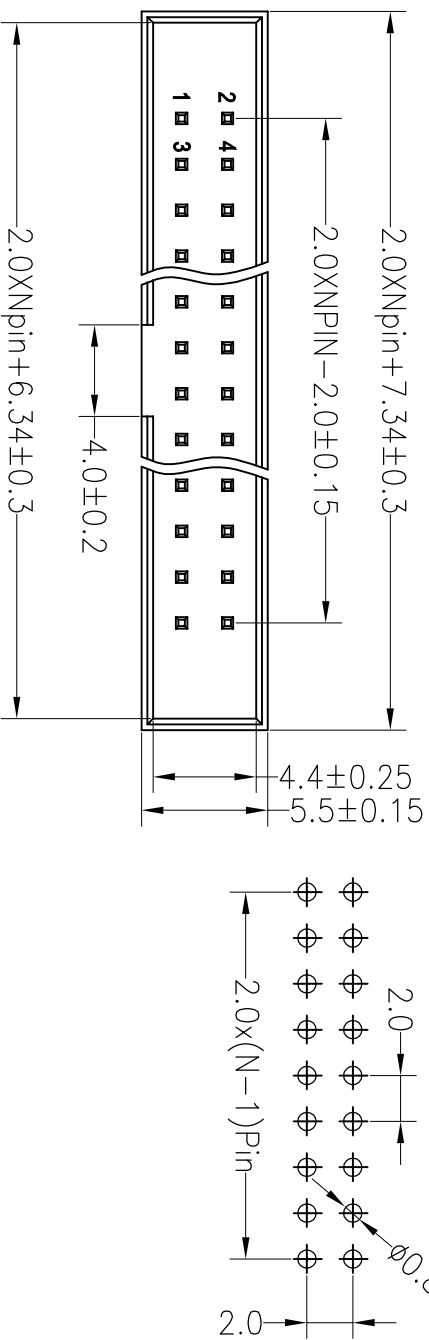

深圳市连盛精密连接器有限公司

REV	DATE	MODIFICATION DESCRIPTION	CHANGE	OPERATION		DRAW		SCALE		FIT	PART NO.	TITLE:
				X.X	±0.30	CHECK	UNIT	mm	SIZE			
A0	2012.03.28	NEW DRAWING		X.XX	±0.20		A4	1/1			BH-00070	2.0BOX H=5.65 10P DIP
1				Angle	±3°	APPROVE						
				DIM	TOL							