

NEW OPTO

鑫永诚传感

惠州市鑫永诚传感科技有限公司

Huizhou Newopto Sensor Technology Co., Ltd.

产品承认书

SPEC FOR APPROVAL

客户名称 Customer	
产品名称 Model Name	数字热释电红外传感器
产品型号 Model No	XYC-PIR214D-D0
承认编号 Approval No	
编制日期 Edit Date	2021-04-18

核准 Approval	审核 Check	编制 Edit
吴伟	王宏建	刘承宇

客户确认(Customer Signatures)		

地址：惠州市惠城区潼侨镇宏村宏川路鑫永诚科技园

电话(Tel):0752—7987222

微信 (WeChat) : V18123965666

网址(Web site):<http://www.xycgd.com>

邮箱(E-mail):wuwei@xycgd.com



XYC-PIR214D-D0 数字热释电红外传感器是将传统热释电红外传感器的敏感元与信号处理芯片集成化设计，将敏感元与 IC 芯片集成封装到传感器屏蔽罩内部，敏感元通过感应外界人体移动产生的红外信号，以差分输入的方式传送到高精度的数字智能处理芯片进行处理，可配置的运动检测单元中实现。一旦检测到运动，中断将被发送到主机系统。主机系统可以通过休眠方式实现超低功耗。主机系统访问器件，读取数据进行信号分析。

The **XYC-PIR214D-D0** digital pyroelectric infrared sensor integrates the sensitive element of the traditional pyroelectric infrared sensor with the signal processing chip, and integrates the sensitive element and the IC chip into the sensor shield. The sensitive element transmits the infrared signal generated by the external human movement to the high-precision digital intelligent processing chip for processing by differential input. When the signal processing is completed, A configurable motion detection unit is implemented. Once motion was detected, an interrupt will be send to the host system. Putting the host system to sleep an overall ultra low power consumption will be achieved. All data is accessible from the host system to enable advanced signal analysis with your own detection criteria.

特性 Feature

- 高精度 AD 信号处理； High precision AD signal processing
- 串行通讯方式： Serial communication

应用 Application

- 长距离的运动检测； Long distance motion detection
- 适用于各类防盗报警用入侵探测器； Applicable to all kinds of intrusion detectors for burglar alarms
- 各种节能场景； Energy saving applications
- 适用于各类智能家用电器； Applicable to all kinds of smart household appliances

优势 Advantages

- 品种齐全, 生产周期短, 小批量库存备货 Complete varieties, short production cycle, Prepared small batch inventory
- 严格的品质保障体系, 让您使用无忧 Strict quality assurance system
- 提供全方位的技术支持服务 Provide a full range of technical support

最大额定值 Maximum Ratings

参数 Parameter	符号 Symbol	最小值 min	最大值 max	单位 unit	备注 note
供电电压 Input voltage	V _{DD}	-0.3	3.6	V	
管脚电流 Pin current	I _{into}	-100	100	mA	
储存温度 Storage temp	T _{st}	-40	85	°C	

工作条件 (T=25°C) Working Condition:

Parameter	Symbol	Min	Typ	Max	Unit	Remarks/Conditions
Operating Voltage	V _{DD}	1.6	3	3.6	V	
Supply Current	I _{DD}		3	3.5	μA	V _{DD} = 1.8 V, no load
SERIN						
Input Low Voltage	V _{SIL}			0.2V _{DD}	V	
Input High Voltage	V _{SIH}	0.8V _{DD}			V	
Input Current	I _{SI}	-1		1	μA	V _{SS} < V _{IN} < V _{DD}
Data Clock Low Time	t _{SL}	200		2000	ns	
Data Clock High Time	t _{SH}	200		2000	ns	
Data In Hold Time	t _{SHD}	72			μs	
Data Load Time	t _{SLT}	580			μs	
DOCI/INT						
Input Low Voltage	V _{DIL}			0.2V _{DD}	V	
Input High Voltage	V _{DIH}	0.8V _{DD}			V	
Input Current	I _{DI}	-1		1	μA	

Data Set-up Time	tDS	75		150	μs	Interrupt Readout Mode
Data Set-up Time	tDS	110		150	μs	Forced Readout Mode
Data Clock Low Time	tDL	200		2000	ns	
Data Clock High Time	tDH	200		2000	ns	
Data Bit Settling Time	tBS			2	μs	C _{LOAD} < 10 pF
Sample Time	tSMPL	2		12.5	ms	
Bit Time	tBIT			22	μs	
ADC Resolution		14			Bits	
PIR ADC Sensitivity		6.5			μV/Count	
PIR ADC Offset		7000	8000	9000	Counts	in stable condition
Sensitivity of T _{AMB}			80		Counts/K	
Counts at 300 K (27 °C)		6620	8200	9980	Counts	
LPF cut-off frequency	f ₁		7		Hz	
HPF cut-off frequency	f ₂		0.2/0.4		Hz	configurable
Internal Clock Frequency	f _{CLK}	28	32	40	kHz	

内部框图 Internal Block Diagram :

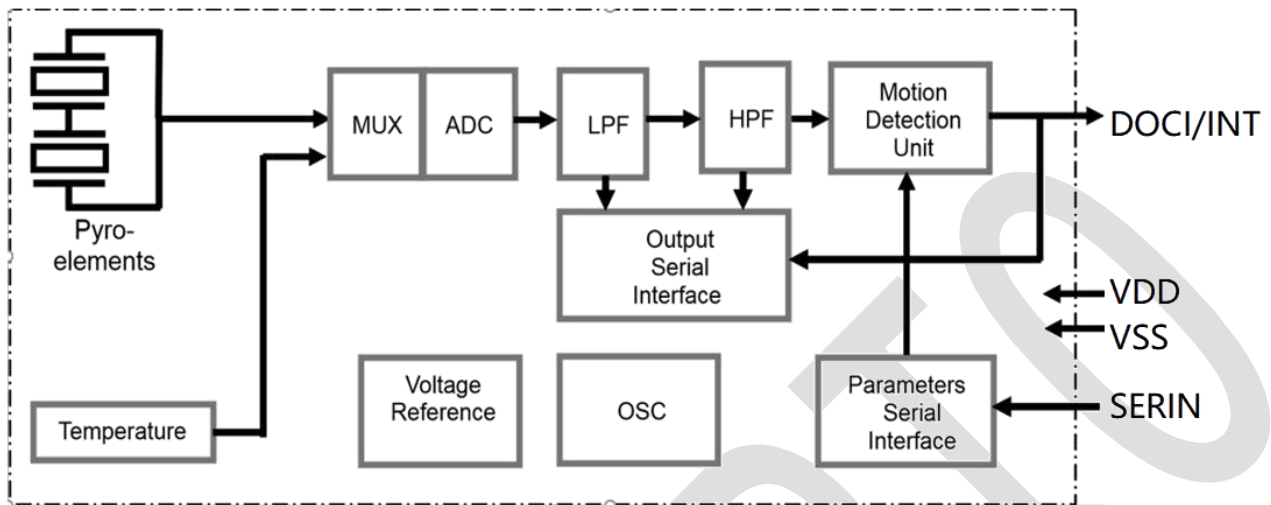

触发模式 :

敏感元连接到内置 IC, IC 包括一个低通和高通滤波器和一个运动检测单元。串行接口“SERIN”被提供给配置的内部寄存器。配置存储器是易失, 这意味着功率后的构成寄存器的设置是不确定的。DOCI / INT 引脚是另外一个串行接口, 可以被配置为:

1. 一旦检测到运动事件发送一个中断。
2. 读来自所述检测器的连续的数据流。

The pyro-electric sensing elements are connected to a built-in IC, Included are also Low- and High-Pass Filters and a Motion Detection Unit. The serial interface “SERIN” is provided to configure the internal registers. The configuration memory is volatile which means that after power up the register settings are undefined.

A second serial interface called “DOCI/INT” can be configured to:

1. Send an interrupt once a motion event is detected.
2. Read a continuous data stream from the detector.

运动检测单元 Motion Detection Unit

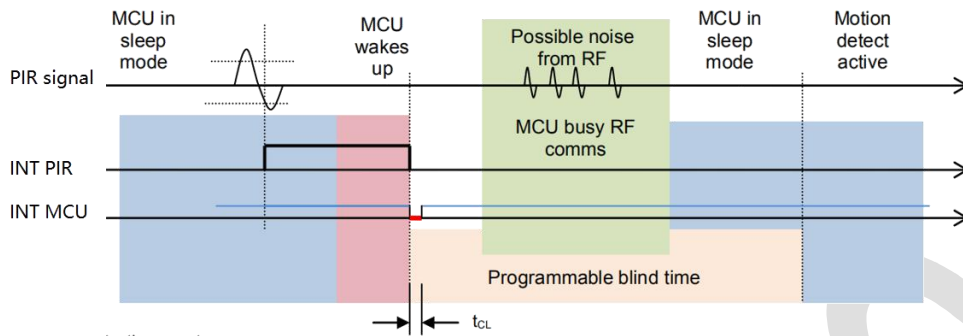

备注：信号是经过 BPF 分析之后的。The signal is always analysed after band pass filtering (BPF).

使能传感器内部运动检测单元，当运动条件都满足“唤醒”模式 DOCI/INT 引脚将被拉高。DOCI/INT 引脚不会自动回到低电平，主机需要将 DOCI/INT 引脚拉低至少 35uS 来清除中断。报警事件被中断复位清零，在盲区时间内停止任何进一步的运动检测。

To enable the internal Motion Detection Unit configure the sensor to "Wake Up" mode . The DOCI/INT will be pulled HIGH when the motion criteria are met. DOCI/INT will not automatically fall back to LOW. To clear the interrupt, DOCI/INT needs to be pulled to LOW by the micro-controller for at least 35 μ s. When the alarm event is cleared by resetting the interrupt, any further motion detection is stopped for the programmed blind time.

配置寄存器 Configuration Register

备注：配置寄存器的内容。寄存器的值在上电后状态不确定。

Register Description	Bit#	Description	Size[bit]	Remarks
Readout Register	[39]	Out of Range	1	0: PIR was reset
Register	[38:25]	ADC counts	14	Value of selected source
Configuration Register	[24:17]	Threshold	8	Detection threshold on BPF value
	[16:13]	Blind Time	4	=0.5 s + [Reg Val] \cdot 0.5 s
	[12:11]	Pulse Counter	2	=1+ [Reg Val]

[10:9]	Window Time	2	$=2\text{ s} + [\text{Reg Val}] \cdot 2\text{ s}$
[8]	Motion detector Enable	1	0 = Disable, 1 = Enable
[7]	Interrupt Source	1	0 = Motion, 1 = Filter
[6:5]	Signal Source	2	0: PIR (BPF) 1: PIR (LPF) 2: Reserved 3: Temperature
[4]	Reserved	1	Reserved: Must be set to dec 1
[3:0]	Reserved	4	Reserved: Must be set to dec 0

Threshold

灵敏度检测阈值与所述寄存器的值来定义。该寄存器的分辨率是 6.5u V

The sensitivity detection threshold is defined with the register value. The resolution of the register is 6.5uV .

$\text{threshold} = [\text{reg_value}] * 6.5\text{ u V}$.

Blind Time

中断输出后被切换回 0，屏蔽的时间范围：0.5 秒~8S。

Ignores motion after the interrupt output is switched back to 0. Range:0.5s~8S.

$\text{Blind time} = [\text{reg_value}] * 0.5\text{S}$

Pulse Counter

在指定的窗口时间内，对高于阈值的脉冲的量进行计数，由 1 个到 4 个脉冲构成。

1~4 pulses with sign change in between.

$\text{Amount of pulses} = [\text{reg_value}] + 1$

Window Time

在给定的移动窗口时间内，对高于阈脉冲进行计数，窗口时间可以设置为从 2 到 8 秒，以 2 秒的间隔

The pulse counter is evaluated for pulses above the threshold within a given moving window time. The window time can be set from 2 s up to 8 s in intervals of 2 s.

Window time=[reg_value]*2s+2s

Motion detector Enable

运动侦测使能 0=disable , 1=enable

Interrupt source

中断源默认运动模式，在 ADC 和 运动 之间进行选择被，中断每隔 16 毫秒（512 / FCLK）生成。

The interrupt source can be selected between motion(default) or ADC Decimation filter.if the decimation filter is selected,interrupts are generated every 16ms (512/FCLK).

0= Motion, 1=ADC

Voltage source for ADC

有如下选项：对于运动检测器模式必须选择 0 或 1。

The following source voltages are selectable for the ADC: For motion detector mode , 0 or 1 has to be selected.

0= PIR Signal, BPF output

1= PIR signal, LPF output

2= Reserved

3= On chip temperature senso

串行接口 Serial In Interface

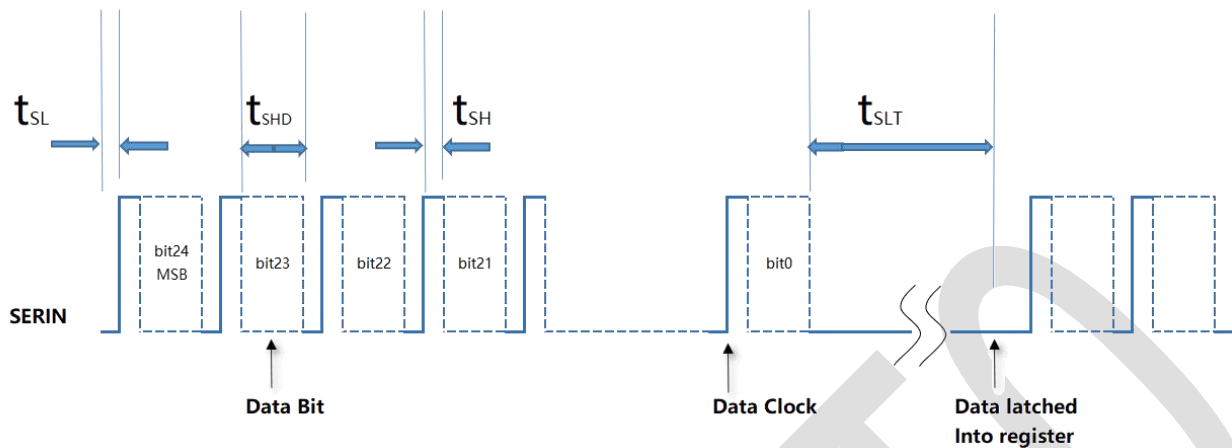

配置数据通过串行输入“SERIN”设置。外部微控制器在SERIN引脚上生成一个上升沿，随后电平表示配置数据的比特值，由SERIN引脚设置为0或1，数据位的时间大于72μs。当设备已经接收到超过25bits数据时，超过580μs以上传送被中断，接收到的LSB被锁存到所述配置寄存器。25位数据字的传输不能超过350μs以上，由于设备可能在这个阶段锁定已经存在的数据。用DOCI/INT引脚读回传感器的配置数据。

The configuration data is set via the serial input "SERIN". The external micro-controller has to generate a LOW to HIGH transition on the SERIN input and subsequently apply the data bit value (LOW or HIGH).

The LOW and HIGH time (t_{SL} and t_{SH}) for the transition can be very short (1 instruction cycle of the microcontroller). The data bit value must be applied for at least $t_{SHD} \geq 72 \mu s$.

Whenever the device has received more than 25 data bits and the transfer of data bits is interrupted for a period greater than $t_{SLT} > 580 \mu s$, the last data received is latched into the configuration register. The transmission of a 25 bit data word should not be interrupted for more than 350 μs, as the device may latch the data already at this stage. To read back the sensor's configuration, the DOCI/INT interface is used.

DOCI / INT 接口 DOCI/INT Interface

DOCI/INT 用来产生中断或不断检索来自传感器数据。

The DOCI/INT interface is a bi-directional one wire serial interface which is used to generate an

interrupt or to continuously retrieve data from the sensor.

Bit#	Description	Size[bit]	Remarks
[39]	Out of Range	1	0: PIR was reset 1: Normal operation
[38:25]	ADC counts	14	Value of selected source
[24:0]	Configuration	25	Register settings

Out of Range

1: 正常 , 0: 表示超出范围

ADC counts

表示 LPF 处理的 ADC 数值、BPF 或的参考温度数值。BPF 数据 为二进制补码 14 位带符号整数的值。LPF 数据和参考温度数据 为 14 位无符号整数。

The data represents either ADC counts after low-pass filtering, after band-pass filtering or the reference temperature counts. The band-pass filtered data is represented as a two's complement 14 bit signed integer value. The low-pass data and the reference temperature data is represented as 14 bit unsigned integer.

Configuration

包含报警事件单元等内容的设置 The settings of the alarm event unit is contained here

数据传输图 Data Transmission Diagram

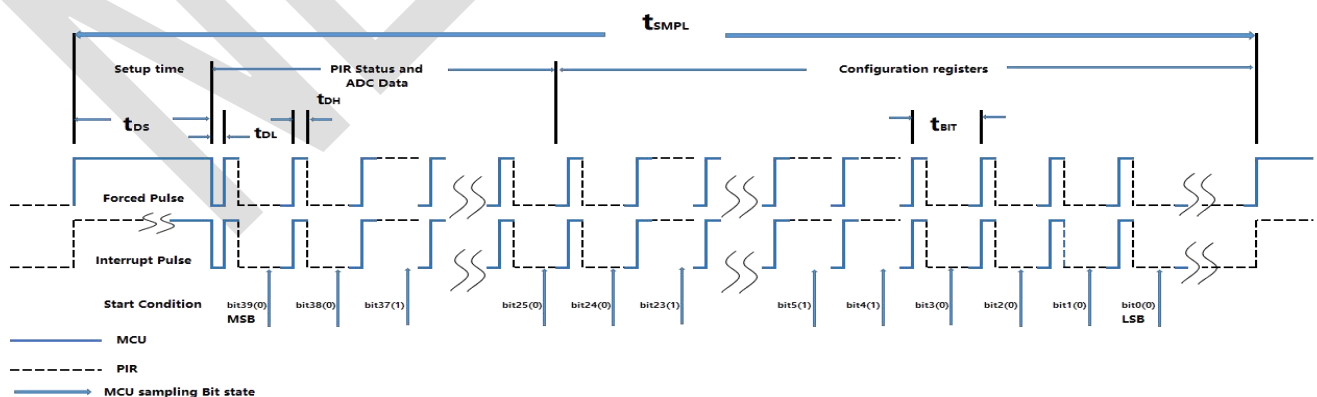

感应角度 Detection Angle :

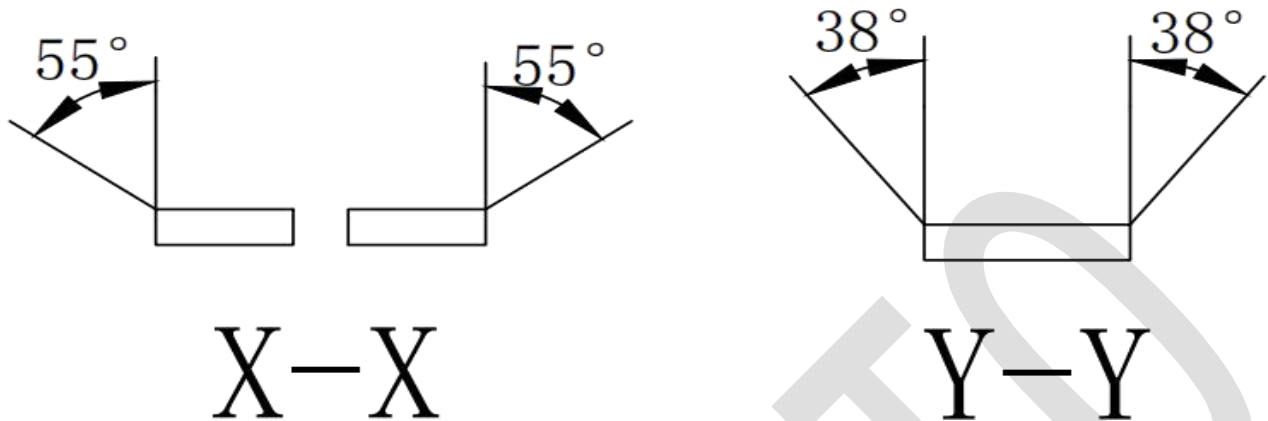

产品外形尺寸 (MM) Product Dimension :

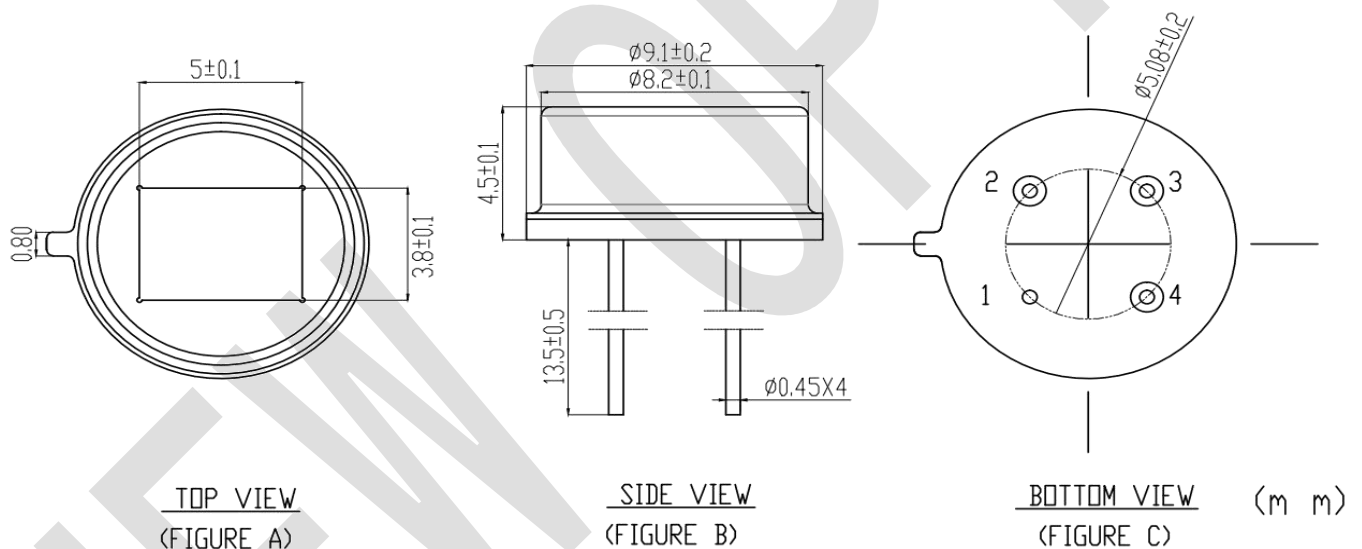

管脚定义:

Pin description:

1	VSS 电源地
2	DOCI/INT 传感器数据输出脚
3	VDD 传感器供电脚
4	SERIN 传感器输入脚, 配置寄存器

信号特性 Signal Feature :

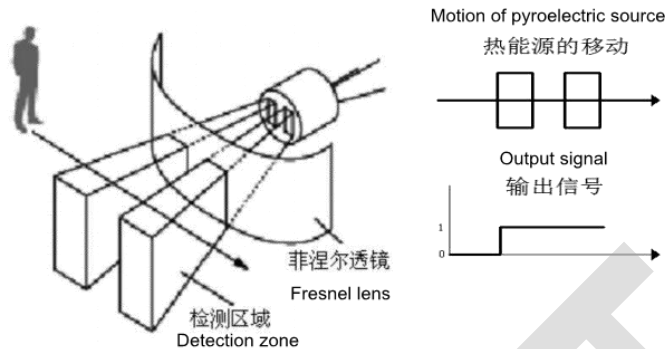

窗口材料的可接收通过波长 : Window material receiving wavelength range

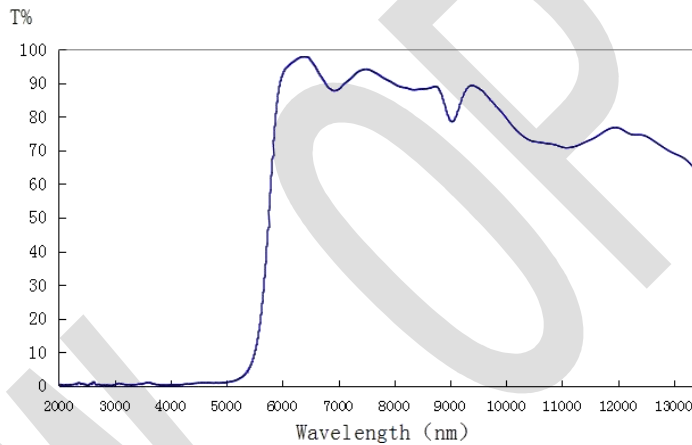

注意：图表所示为典型的 5.5um 红外滤光片参考图，曲线是红外线通过率的平均值。

Note: the chart shows a typical 5.5um infrared filter reference chart. The curve is the average of the infrared pass rate.

典型应用电路 Typical application circuit :

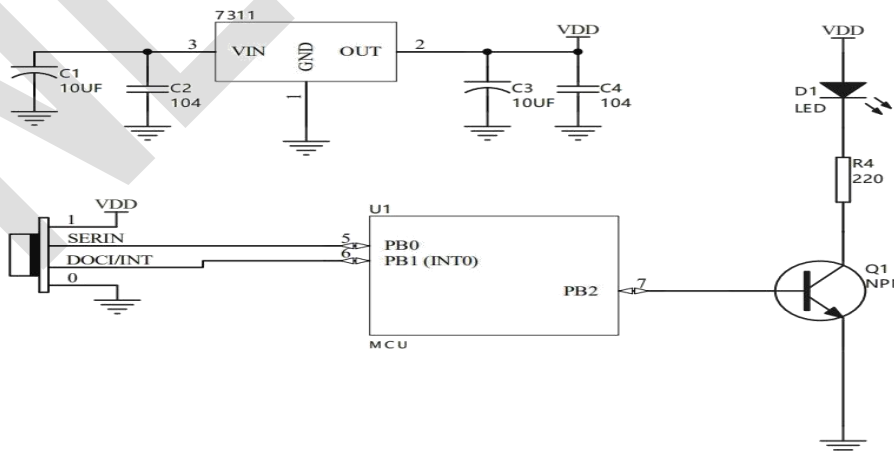

焊接 Soldering :

焊接过程中的不慎操作将会引起产品的损坏,请务必注意。焊接过程中应避免对产品支架或封装部分施加压力。焊接时,请保证焊接位置与传感器底部有一定的距离,该距离因不同的焊接方法而有所不同,请参照以下推荐焊接条件。

Careless operation during soldering will cause damage to the product, please be careful. Please avoid put pressure on the product bracket or package part during soldering. When soldering, please ensure that the soldering position has a certain distance from the bottom of the sensor. This distance varies with different welding methods. Please refer to the recommended welding conditions below.

推荐焊接条件 Recommended Soldering Conditions

焊接模式 Soldering Mode		固定形式 Fixed Form
手工焊接 manual soldering	烙铁温度 Soldering iron temperature	240-280°C
	焊接时间 Soldering time	2-4 秒 2-4 seconds
	焊接位置 Soldering position	大于 3mm (从焊点到底座) More than 3mm(from solder joint to base)
锡炉焊接 Tin stove welding	预热 Preheat	最高温度 100°C 不超过 60 秒 Highest temperature 100 degree, not more than 60 seconds
	浸焊温度 Dip soldering temperature	最高 280°C Max 280 degree
	浸焊时间 Dip soldering time	不超过 5 秒 Not more than 5 seconds
	焊接位置 Soldering position	大于 3mm (从焊点到底座) More than 3mm(from solder joint to base)

使用注意事项 Caution :

感谢您使用惠州市鑫永诚传感科技有限公司的 PIR 系列产品,为增进您对我公司产品特性的了解,也为方便您快速掌握产品的基本操作,为尽量减少或避免因人为等因素造成不必要的产品损坏,使其能够更好的为您的生产服务,特针对使用过程中的一些规范使用作相应说明,同时即使是同一规格 PIR,在实际应用领域其可靠性与整体系统设计水平、作业方式、使用条件均相关。本使用说明不可能涵盖客户使用过程中可能碰到的所有问题,由此带来的不便,敬请谅解!

Thanks for using Huizhou Newopto Sensor Technology Co.,Ltd PIR series products. In order to enhance

your understanding of our products characteristics and avoid unnecessary damage due to man made factors,we provide corresponding operation standard instruction.At the same time,even if you are using the same specification PIR,its reliability is related to overall system design level,operation mode and use condition.This instruction couldn't cover all questions customers may meet during using.We apologize for any inconvenience caused sincerely.

■ 产品声明 Product Declaration

- 传感器的出厂参数是在标准黑体和相关参数测试条件下经过一分钟稳定时间后测试所得。
- The factory parameters of the sensor are tested after one minute stabilization time under standard blackbody and related parameter test conditions.
- 使用本产品之前，请贵司务必预先进行测试，以便确认是否适合使用目的，产品介绍的用途并不保证不抵触任何专利，有关 PIR 产品的进出口法律责任应由客户担负，请预先查清每个国家或地区的有关规定，产品可能会因性能提供或规格参数改变等缘故，恕不经预告更改，我们要求量产前签订正式的产品规格书
- In order to confirm the product is right for using purpose , pretest is necessary before use . We don't guarantee the product application introduction don't contravene any patent. The corresponding import and export legal responsibility should be taken by customers. Please verify relevant provision in each country and district beforehand. We may change specifications from time to time in the interest of product development,without prior notification or public announcement.We require formal product specifications to be signed before mass production.

■ 储存 Storage

- 在温度不高于 30℃，湿度不高于 60%RH 的条件下，产品保存期限为 6 个月。将产品保存在密封的容器中并附带干燥剂可以在一定程度上延续产品的储存日期。不良的储存条件会导致产品引脚的腐蚀或产品性能的改变。
- Under the storage conditions of 30℃ or less and humidity less than 60%RH, the storage period is 6months. Store the products in sealed container with moisture absorbent could prolong the storage time to a certain extent. Bad storage conditions may cause the product pin corrode or characteristics change.

■ 静电 Static

- 静电和电涌会导致产品特性发生改变，例如正向电压降低等，如果情况严重甚至会损毁产品，所以在使用时必须采取有效的防静电措施。所有相关的设备和机器都应该正确的接地，同时必须采取其他防静电和电涌的措施。使用防静电手环，防静电垫子，防静电工作服，工作鞋，手套，防静电容器，都是有效的防止静电和电涌的措施。
- Static and electric surge would change the product features,such as decreasing forward voltage or damage the products.Please make sure adopt effective anti-static measures. All the relative devices and machinery must be properly grounded.And please use anti-static wrist bands,anti-electrostatic gloves, anti-electrostatic containers at the same time to prevent static and electric surge.

■ 设计建议 Design Suggestion

- 设计产品时请注意传感器的窗口方向，结合菲涅尔透镜来达到较理想的探测角度。

- Please pay attention to the window direction of the sensor when designing the product, and combine the Fresnel lens to achieve a better detection angle.
 - 传感器的距离和背景温度、移动中的目标温度、菲涅尔透镜、环境温度、放大器放大倍数设置均有直接关系，使用时需综合考虑各参数。
 - The sensor detection distance is related to the background temperature, the moving target temperature, the Fresnel lens, the ambient temperature, and the amplifier magnification setting. It is necessary to consider all parameters when using.
- 其它 Others
- 传感器采用金属外壳密闭封焊而成，为保证器件的气密性，使用过程中不建议对引线进行弯折，弯折可能会破坏玻璃和金属封接部位的气密性，造成器件漏气。如果需要弯折使用，请使用工具辅助，并保证折弯过程中引线根部不受力。请保证折弯点与传感器底座之间有 3mm 以上的距离。使用过程中不可轴向扭动引线。
 - The sensor is sealed by a metal casing. In order to ensure the airtightness of the device, it is not recommended to bend the lead during use. Bending the lead may damage the airtightness of the glass and metal sealing parts, cause air leakage. If you need to bend, please use tool assist and ensure that the root of the lead is not stressed during the bending process. Please ensure the distance between the bending point and sensor base is more than 3mm. Do not twist the leads axially during use.
 - 传感器窗口镜片为半导体硅片经特殊材料真空镀膜的滤光片，使用时不能用手或硬物直接接触窗口，如滤光片有脏污，可用绒布沾无水乙醇适度擦拭。
 - The sensor window lens is a semiconductor wafers filter vacuum coated by special materials. Please don't touch the window with your hands or hard objects when using. If the filter is dirty, please wipe it with absolute ethanol by lint-free cloth.
 - 传感器应避免机械冲击，频繁、过度振动会导致传感器内部敏感元断裂，使用时需轻拿轻放。
 - Please avoid mechanical shock for the sensor. Frequent or excessive vibration will cause the sensitive element break.