

極数 CKT	部品番号 PARTS No.	A	B	C
6	12001S-06B-GFN1	2.5	7.1	8.4
7	12001S-07B-GFN1	3.0	7.6	8.9
8	12001S-08B-GFN1	3.5	8.1	9.4
9	12001S-09B-GFN1	4.0	8.6	9.9
10	12001S-10B-GFN1	4.5	9.1	10.4
11	12001S-11B-GFN1	5.0	9.6	10.9
12	12001S-12B-GFN1	5.5	10.1	11.4
13	12001S-13B-GFN1	6.0	10.6	11.9
14	12001S-14B-GFN1	6.5	11.1	12.4
15	12001S-15B-GFN1	7.0	11.6	12.9
16	12001S-16B-GFN1	7.5	12.1	13.4
17	12001S-17B-GFN1	8.0	12.6	13.9
18	12001S-18B-GFN1	8.5	13.1	14.4
19	12001S-19B-GFN1	9.0	13.6	14.9
20	12001S-20B-GFN1	9.5	14.1	15.4
21	12001S-21B-GFN1	10.0	14.6	15.9
22	12001S-22B-GFN1	10.5	15.1	16.4
23	12001S-23B-GFN1	11.0	15.6	16.9
24	12001S-24B-GFN1	11.5	16.1	17.4
25	12001S-25B-GFN1	12.0	16.6	17.9
26	12001S-26B-GFN1	12.5	17.1	18.4
27	12001S-27B-GFN1	13.0	17.6	18.9
28	12001S-28B-GFN1	13.5	18.1	19.4
29	12001S-29B-GFN1	14.0	18.6	19.9
30	12001S-30B-GFN1	14.5	19.1	20.4
31	12001S-31B-GFN1	15.0	19.6	20.9
32	12001S-32B-GFN1	15.5	20.1	21.4
33	12001S-33B-GFN1	16.0	20.6	21.9
34	12001S-34B-GFN1	16.5	21.1	22.4
35	12001S-35B-GFN1	17.0	21.6	22.9
36	12001S-36B-GFN1	17.5	22.1	23.4
37	12001S-37B-GFN1	18.0	22.6	23.9
38	12001S-38B-GFN1	18.5	23.1	24.4
39	12001S-39B-GFN1	19.0	23.6	24.9
40	12001S-40B-GFN1	19.5	24.1	25.4
41	12001S-41B-GFN1	20.0	24.6	25.9
42	12001S-42B-GFN1	20.5	25.1	26.4
43	12001S-43B-GFN1	21.0	25.6	26.9
44	12001S-44B-GFN1	21.5	26.1	27.4
45	12001S-45B-GFN1	22.0	26.6	27.9
46	12001S-46B-GFN1	22.5	27.1	28.4
47	12001S-47B-GFN1	23.0	27.6	28.9
48	12001S-48B-GFN1	23.5	28.1	29.4
49	12001S-49B-GFN1	24.0	28.6	29.9
50	12001S-50B-GFN1	24.5	29.1	30.4
51	12001S-51B-GFN1	25.0	29.6	30.9
52	12001S-52B-GFN1	25.5	30.1	31.4
53	12001S-53B-GFN1	26.0	30.6	31.9
54	12001S-54B-GFN1	26.5	31.1	32.4
55	12001S-55B-GFN1	27.0	31.6	32.9
56	12001S-56B-GFN1	27.5	32.1	33.4
57	12001S-57B-GFN1	28.0	32.6	33.9
58	12001S-58B-GFN1	28.5	33.1	34.4
59	12001S-59B-GFN1	29.0	33.6	34.9
60	12001S-60B-GFN1	29.5	34.1	35.4
64	12001S-64B-GFN1	31.5	36.1	37.4
68	12001S-68B-GFN1	33.5	38.1	39.4
70	12001S-70B-GFN1	34.5	39.1	40.4

NOTE
1. コプラナリティ/COPLANARITY: 0.1MAX

△						MATERIAL 材質	GENERAL TOLERANCES 一般公差	SCALE 尺度	UNIT 単位	TITLE 名称
△						①ハウジング/HOUSING: LCP 自然色/NATURAL UL94V-0	DIM 寸法 ± 0.3	DR '15-12-10 F. Oguro	MM	12001シリーズ ソケット SERIES 12001 SOCKET
△						②カバー/COVER: LCP 黒色/BLACK UL94V-0	ANGLE 角度 ±	CHK 15-12-10 T. Tabata	DSN '15-12-10 F. Oguro	EDP No
△						③端子/CONTACT: リン青銅/PHOSPHOR BRONZE		APP 15-12-10 T. Tabata		PARTS No 部番
△						④底保持端子/HALF LOCK CONTACT: リン青銅/PHOSPHOR BRONZE	3RD. ANG. PROJ. 三角法			IMS-A12001S-*#B-GFN1
△						⑤金属/METAL FLANGE: 黄銅/BRASS				DWG No 図番
△						FINISH 仕上げ				REV. 0
△						①ニッケル下地めっき/OVER Ni PLATE: 2.0μmMIN		IRISO ELECTRONICS CO., LTD		
△						②金めっき/Au PLATE: 0.1μmMIN		I/I 電子工業株式会社		
△						③ニッケル下地めっき/OVER Ni PLATE: 2.0μmMIN				
△						④金めっき/Au PLATE: 0.03μmMIN (テール部/TAIL AREA)				
△						⑤⑥ニッケル下地めっき/OVER Ni PLATE: 0.5~2μm				
△						⑦銅半光沢めっき/TIN MATT PLATE: 3.0μmMIN				
△	SDP/	RELEASED	J. O	T. T	'15-12-10					
△	LR 記号	ECN No	REVISION RECORD 事	DR	CHK	DATE 年月日				

DO NOT SCALE DRAWING.
THIS DRAWING CONTAINS INFORMATION THAT IS PROPRIETARY TO IRISO AND SHOULD NOT BE USED WITHOUT WRITTEN PERMISSION. 本図面は、イリソ電子工業(株)の所有する情報を含むもので当社の許可なく複製を禁止する。

REDUSED COPY

A B C D E F G H

製品引き出し方向
PRODUCT WITHDRAWAL DIRECTION

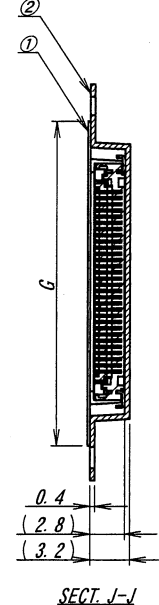
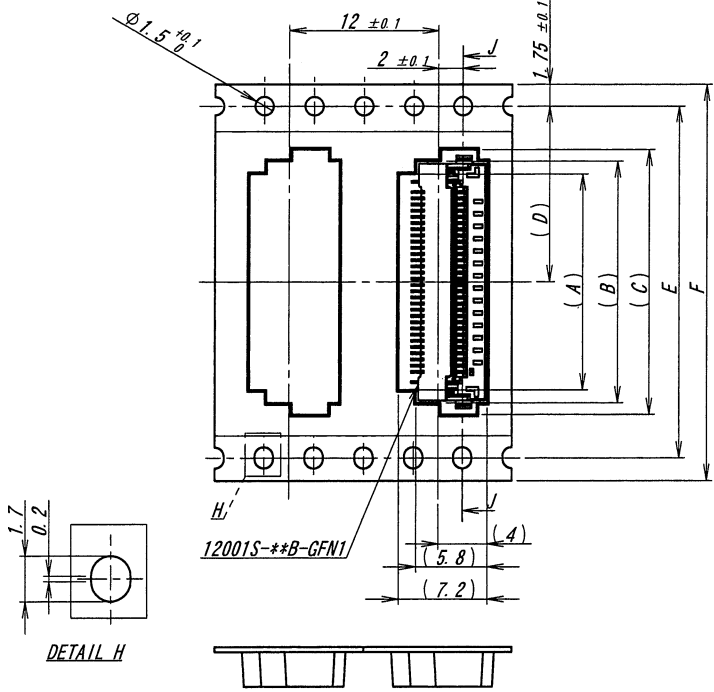

SECT. J-J

NOTE

- 1. 梱包数量/UNIT QUANTITY:2000
- 2. リードテープ長さ/LEAD TAPE LENGTH

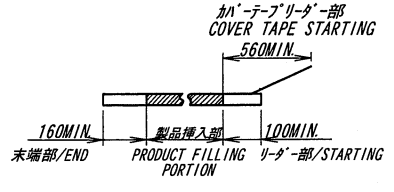

3. 24mm幅はシングルキャリア
F=24mm IS SINGLE CARRIER

4. カバーテープの剥離強度/COVER TAPE PEELING FORCE : 0.1N~1.3N

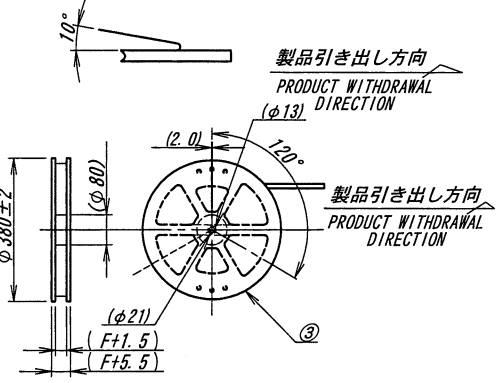

極数/CKT	部品番号/PARTS No.	A	B	C	D	E	F	G
6	12001S-06Y903	5.4	7.5	9.4	11.5	24.0	21.5	
7	12001S-07Y903	5.9	8.0	9.9				
8	12001S-08Y903	6.4	8.5	10.4				
9	12001S-09Y903	6.9	9.0	10.9				
10	12001S-10Y903	7.4	9.5	11.4				
11	12001S-11Y903	7.9	10.0	11.9				
12	12001S-12Y903	8.4	10.5	12.4	14.2	28.4	32.0	26.0
13	12001S-13Y903	8.9	11.0	12.9				
14	12001S-14Y903	9.4	11.5	13.4				
15	12001S-15Y903	9.9	12.0	13.9				
16	12001S-16Y903	10.4	12.5	14.4				
17	12001S-17Y903	10.9	13.0	14.9				
18	12001S-18Y903	11.4	13.5	15.4				
19	12001S-19Y903	11.9	14.0	15.9				
20	12001S-20Y903	12.4	14.5	16.4				
21	12001S-21Y903	12.9	15.0	16.9				
22	12001S-22Y903	13.4	15.5	17.4				
23	12001S-23Y903	13.9	16.0	17.9				
24	12001S-24Y903	14.4	16.5	18.4				
25	12001S-25Y903	14.9	17.0	18.9				
26	12001S-26Y903	15.4	17.5	19.4	20.2	40.4	44.0	37.0
27	12001S-27Y903	15.9	18.0	19.9				
28	12001S-28Y903	16.4	18.5	20.4				
29	12001S-29Y903	16.9	19.0	20.9				
30	12001S-30Y903	17.4	19.5	21.4				
31	12001S-31Y903	17.9	20.0	21.9				
32	12001S-32Y903	18.4	20.5	22.4				
33	12001S-33Y903	18.9	21.0	22.9				
34	12001S-34Y903	19.4	21.5	23.4				
35	12001S-35Y903	19.9	22.0	23.9				
36	12001S-36Y903	20.4	22.5	24.4				
37	12001S-37Y903	20.9	23.0	24.9				
38	12001S-38Y903	21.4	23.5	25.4				
39	12001S-39Y903	21.9	24.0	25.9				
40	12001S-40Y903	22.4	24.5	26.4	26.2	52.4	56.0	49.0
41	12001S-41Y903	22.9	25.0	26.9				
42	12001S-42Y903	23.4	25.5	27.4				
43	12001S-43Y903	23.9	26.0	27.9				
44	12001S-44Y903	24.4	26.5	28.4				
45	12001S-45Y903	24.9	27.0	28.9				
46	12001S-46Y903	25.4	27.5	29.4				
47	12001S-47Y903	25.9	28.0	29.9				
48	12001S-48Y903	26.4	28.5	30.4				
49	12001S-49Y903	26.9	29.0	30.9				
50	12001S-50Y903	27.4	29.5	31.4				
51	12001S-51Y903	27.9	30.0	31.9				
52	12001S-52Y903	28.4	30.5	32.4				
53	12001S-53Y903	28.9	31.0	32.9				
54	12001S-54Y903	29.4	31.5	33.4				
55	12001S-55Y903	29.9	32.0	33.9				
56	12001S-56Y903	30.4	32.5	34.4				
57	12001S-57Y903	30.9	33.0	34.9				
58	12001S-58Y903	31.4	33.5	35.4				
59	12001S-59Y903	31.9	34.0	35.9				
60	12001S-60Y903	32.4	34.5	36.4				
64	12001S-64Y903	34.4	36.5	38.4				
68	12001S-68Y903	36.4	38.5	40.4				
70	12001S-70Y903	37.4	39.5	41.4				

	MATERIAL 材質	<p>①カバーテープ/COVER TAPE : PET TYPE</p> <p>②キャリアテープ/CARRIER TAPE : PS</p> <p>③リール/REEL : PS 黒色/BLACK</p>	<p>GENERAL TOLERANCES 一般公差</p> <p>DR 寸法 ± 0.3</p> <p>ANGLE 角度 ±</p>	<p>SCALE 尺度 /</p> <p>DR '15-12-10 <i>G. Oguro</i></p> <p>CHK '15-10-10 <i>T. Takami</i></p>	<p>UNIT 単位 mm</p> <p>DSN '15-12-10 <i>G. Oguro</i></p> <p>APP '15-12-10 <i>Y. Kobayashi</i></p>	<p>TITLE 名称 12001シリーズ FFC/FPC ソケット エンボス梱包品 SERIES 12001 FFC/FPC SOCKET EMBOSS PRODUCT</p>
	FINISH 仕上げ	3RD. ANG. PROJ. 三角法	IRISO ELECTRONICS CO., LTD イリス電子工業株式会社	<p>EDP No</p> <p>PARTS No 部番 IMSA-12001S-**Y903</p> <p>DWG No 図番 120-412001-001</p> <p>REV. 0</p>		
<p>1098/</p> <p>ECN No</p>	<p>RELEASED</p> <p>REVISION RECORD 記 番</p>	<p>J.O</p> <p>DR</p>	<p>T.T</p> <p>CHK</p>	<p>'15-12-10</p> <p>DATE 年月日</p>	<p>DO NOT SCALE DRAWING.</p> <p>THIS DRAWING CONTAINS INFORMATION THAT IS PROPRIETARY TO IRISO AND SHOULD NOT BE USED WITHOUT WRITTEN PERMISSION. 本図面は、イリス電子工業(株)の所有する情報を含みますので当社の許可なく複製を禁止します。</p>	

REDUCED COPY

製品仕様書／Product Specification	No.	IS-12001A	来歴	3
	頁/Page	1/8		
標題：12001 シリーズ 0.5mmピッチ FPC/FFC コネクタ SUBJECT：Series 12001 0.5mm Pitch FPC/FFC Connector	制定年月日/ISSUED DATE	2011-03-15		
	改訂年月日/REVISED DATE	2011-12-12		

1. 適用範囲

本仕様書はイリソ電子工業株式会社製 12001 シリーズ 0.5mmピッチ FPC/FFC コネクタに関する仕様及び性能上の必要事項について規定する。

2. 構造及び寸法

構造、寸法、主要部品の材質、表面処理等は添付図による。
 適合 FPC/FFC：0.5mm ピッチ、厚さ：0.3±0.03mm
 適用ソケット：IMSA-12001S-***-GFN1

3. 定格

- (1)最大定格電圧 50V (AC, DC)
- (2)最大定格電流 0.5A
- (3)使用温度範囲 -40～+105℃
(通電による温度上昇含む)

4. 試験環境

特に規定のある場合を除き、性能試験は、下記の試験条件のもとで行う。
 常温 15～35℃
 常湿 25～85%RH (相対湿度)

5. 性能

5-1. 電気的性能

項目/Item	条件/Test condition	規格/Specification
1 接触抵抗 Contact Resistance	短絡電流 1mA、最大開放電圧 20mV、周波数 1kHz のローレベル抵抗計にて測定する。 It shall be measured by the dry electric circuit specified as follows ; 1mA, 20mV, 1kHz frequency.	初期値：40mΩ以下 各試験後：80mΩ以下 Initial : 40mΩ or below. After each test : 80mΩ or below
2 耐電圧 Dielectric Withstanding Voltage	隣接する極間に AC250V を 1 分間印加する。 AC 250V shall be applied for one minute to between next terminals and the earth .	絶縁破壊等異常のない事。 Should not have any changes.
3 絶縁抵抗 Insulation resistance	隣接する極間に DC250V を印加する。 DC 250V shall be applied to between next terminals .	初期値：100MΩ以上 耐湿試験後：100MΩ以上 Initial : 100MΩ or more. After humidity test : 100MΩ or more
4 外観 Appearance	目視 Visual	有害となる割れ、剥かし、ガタ、変形、変色のない事。 Should not have any flaw, scratch, discoloration, and crushed.

1. Scope

This product specification is applied for IRISO ELECTRONICS CO.,LTD. Series 12001 0.5mm Pitch FPC/FFC Connector.

2. Configuration, dimensions and materials

See the product drawing attached.
 FPC/FFC Mated : 0.5mm Pitch、t=0.3±0.03mm
 Applied to socket : IMSA-12001S-***-GFN1

3. Rating

- (1) Maximum rating voltage : 50 V(AC,DC)
- (2) Maximum rating current: 0.5A
- (3)Temperature range : -40～+105℃
(Rise in heat is included)

4. Performances

All performance test, unless otherwise specified, is taken as per following environmental conditions.
 Ambient temperature : 15～35℃
 Ambient temperature :25～85%RH

5. Performance

5-1.Electrical performance

5-2. 機械的特性

5-2. Functional Performance

項目/Item	条件/Test condition	規格/Specification
1 端子の保持力 Contact retention force	端子に 25mm/分の速度で荷重を加え、端子がハウジングより抜け始めるまでの荷重を測定する。 It shall be pulled to the contact at the speed of 25mm per minute, and measured the force when the contact begins to remove from the housing.	0.49N 以上 0.49N or more
2 挿抜耐久性 Insertion /Extraction endurance	FPC/FFC を 20 回繰返し挿抜を行ない接触抵抗を測定する。 (カバーを開閉し、開時毎に挿抜する。) The FPC/FFC shall be mated and unmated 20 times and measured The contact resistance.	80mΩ 以下 80mΩ or below.
3 衝撃試験 Shock test	FPC/FFC を嵌合した状態にて治具に取り付け、加速度 980m/s ² 、衝撃作用時間 6ms を X,Y,Z,方向の 6 面に各 10 回加え、試験中の瞬断の有無の確認、試験後の接触抵抗の測定及び外観観察する。 The connector and FPC/FFC mated are installed in the machine. They are applied pulses 10 times to each 6 faces of 3 mutually perpendicular directions(X,Y,Z); in conditions as specified ; acceleration of 980m/s ² and shock pulses for a duration of 6ms . It shall be tested the discontinuity of the contact current during the test and measured the contact resistance and observed its appearance after the test	試験中 1 μs 以上の瞬断の無き事。 80mΩ 以下 外観：異常なきこと Discontinuity : 1 μs or less. 80mΩ or below. Should not have any damages

項目/Item	条件/Test condition	規格/Specification
4 振動試験 Vibration test	FPC/FFC を嵌合した状態にて、振動周波数 10~500~10Hz、掃引時間 12 分、振幅 1.5mm、又は加速度 98m/s ² のいずれか小さい方にて X 軸方向に 4 時間、Y Z 軸方向に各 2 時間計 8 時間の振動を加える。試験中、瞬断の有無の確認、試験後の接触抵抗の測定及び外観観察をする。 The connector and FPC/FFC mated is vibrated in the frequency range of 10~500~10Hz/12min and in the constant vibration amplitude 1.5mm or the acceleration of 98m/s ² . The amplitude or the acceleration above shall be chosen either one under which the connectors is loaded more slightly. And this motion is applied for period of 4hours in one of 3 mutually perpendicular directions (X-axis), and 2hours in other two of them (Y and Z-axis). It shall be tested the discontinuity of the contact current during the test and measured the contact resistance and observed its appearance after the test.	試験中 1 μs 以上の瞬断の無き事。 80mΩ 以下 外観に異常無き事。 Discontinuity : 1 μs or less. 80mΩ or below. Should not have any damages.
5 FPC/FFC 挿抜力 (仮保持力) Insertion/ extraction force (Half lock force)	FPC/FFC とソケットを 25mm/分の速度で挿抜を行ない、この時の荷重を測定する。 The FPC/FFC and socket shall be mated and unmated at the speed of 25mm per minute and measured the force of insertion and extraction.	初期値にて/Initial 挿入力 : 0.8~6.0N 抜去力 : 0.8N 以上 Insertion force : 0.8~6.0N Extraction force : 0.8N or more
6 FPC/FFC 保持力 FPC/FFC retention force	FPC/FFC に 25mm/分の速度で加重を加え、ハウジングより抜け始めたときの荷重を測定する。 The FPC/FFC shall be pulled at the speed of 25mm per minute and measured the force when the FPC/FFC begins to remove from the housing.	0.196N/極 以上 0.196N/PIN or more.
7 カバー開閉力 Cover opening-and -closing force	FPC/FFC を挿入した状態でカバーの開閉を行ない、この時の荷重を測定する。 The connector and FPC/FFC mated is measured opening and closing force of cover.	初期値にて/Initial 開力 : 0.05~0.2N/極 閉力 : 0.1~0.55N/極 Opening force : 0.05~0.2N/pin Closing force : 0.1~0.55N/pin

5-3. 環境特性

5-3.Environmental performance

項目/Item	条件/Test condition	規格/Specification
1 耐熱性 Heat resistance	FPC/FFC を嵌合した状態にて温度 105±2℃の恒温槽に 96 時間放置し、放置後接触抵抗測定及び外観観察を行う。 The connector and FPC/FFC mated is exposed in the heat Chamber 105±2℃ for 96 hours. It shall be measured the contact resistance and observed its appearance after the test.	80mΩ 以下 外観異常なき事。 80mΩ or below. Should not have any damages.
2 耐寒性 Load of chill	FPC/FFC を嵌合した状態にて温度 -40±2℃の恒温槽に 96 時間放置し、試験後接触抵抗測定及び外観観察を行う。 The connector and FPC/FFC mated is exposed in the chilly chamber -40±2℃ for 96 hours. It shall be measured the contact resistance and observed its appearance after the test.	80mΩ 以下 外観に異常無き事。 80mΩ or below. Should not have any damages
3 耐湿性 Humidity	FPC/FFC を嵌合した状態にて温度 60±2℃、相対湿度 95%RH の恒温恒湿槽に 96 時間放置し、試験後接触抵抗測定及び外観観察を行う。 The connector and FPC/FFC mated is exposed in the heat chamber 60±2℃, 95%RH for 96 hours. It shall be measured the contact resistance and observed its appearance after the test.	80mΩ 以下 外観に異常無き事。 80mΩ or below. Should not have any damages
4 H ₂ S ガス試験 H ₂ S gas test	FPC/FFC を嵌合した状態にて、温度 40±2℃相対湿度 75%RH、濃度 3±1ppm の雰囲気中に 96 時間放置し、試験後接触抵抗を測定する。 The connector and FPC/FFC mated is exposed in the H ₂ S gas chamber 40±2℃, 75%RH 3±1ppm for 96 hours. It shall be measured the contact resistance after the test.	80mΩ 以下 外観に異常無き事。 80mΩ or below. Should not have any damages
5 SO ₂ ガス試験 SO ₂ gas test	FPC/FFC を嵌合した状態にて、温度 40±2℃相対湿度 75%RH、濃度 10±3ppm の雰囲気中に 96 時間放置し、試験後接触抵抗を測定する。 The connector and FPC/FFC mated is exposed in the SO ₂ gas chamber 40±2℃, 75% RH 10±3ppm for 96 hours. It shall be measured the contact resistance after the test.	80mΩ 以下 外観に異常無き事。 80mΩ or below. Should not have any damages
6 塩水噴霧試験 Salt spray test	FPC/FFC を嵌合した状態にて、温度 35±2℃、濃度 5±1%、の塩水噴霧中に 48 時間放置し、試験後接触抵抗を測定する。 The connector and FPC/FFC mated is exposed in the salt spray chamber 35±2℃, 5±1% salt density for 48 hours. It shall be measured the contact resistance after the test.	80mΩ 以下 外観に異常無き事。 80mΩ or below. Should not have any damages

項目/Item	条件/Test condition	規格/Specification
7 冷熱衝撃試験 Thermal shock test	<p>FPC/FFC を嵌合した状態にて下図の温度条件を 1 サイクルとして 10 サイクル実施し、試験後接触抵抗測定及び外観観察を行う。</p> <p>The connector and FPC/FFC mated is exposed 10 cycles in the following temperature conditions. It shall be measured the contact resistance and observed its appearance after the test.</p>	<p>80mΩ以下 外観に異常無き事。 80mΩ or below. Should not have any damages</p>
8 温湿度 サイクル試験 Humidity resistance	<p>FPC/FFC を嵌合した状態にて下図の温度条件を 1 サイクルとして 10 サイクル実施し、試験後接触抵抗測定及び外観観察を行う。</p> <p>The connector and FPC/FFC times mated is exposed 10 cycles in the following temperature conditions. It shall be measured the contact resistance and observed its appearance after the test.</p>	<p>80mΩ以下 外観異常なき事。 80mΩ or below. Should not have any damages.</p>

5-4. その他の性能

5-4.Other specification

項目/Item	条件/Test condition	規格/Specification
1 半田付け性 Solderability	<p>コネクタの半田付け部をフラックスに浸漬した後、245±5°Cの Sn-Ag-Cu 系の鉛フリー半田槽に 3±0.5 秒浸す。</p> <p>The terminal of connector shall be put into the flux and dipped into Pb free solder bath(Type of Sn-Ag-Cu) 245±5°C, 3±0.5s .</p>	<p>浸した面積の 95%以上に半田が むらなく付着する事。 Solder shall be covered 95% or more of the area that is Dipped into the solder bath</p>
2 半田耐熱性-1 (スタンダード条件) Soldering heat test (Standard condition)	<p>下記条件にて、半田耐熱試験を行う。</p> <p>The connector shall be tested resistance to soldering heat in the following conditions.</p> <p>(1)リフローの場合 / In case of reflow リフロー回数 / number of reflow: 2回 / Twice 250°C(ピーク温度),MAX10s (Peak temperature)</p> <p>(予熱 130~180°C) (pre-heat : from 130~180°C)</p> <p>温度は製品上面の温度とする。 The temperature shall be measured on the surface of the Product.</p> <p>条件② : 手半田の場合/In case of manual soldering. 半田鍍温度/Solder iron : 350±5°C 時間/time : 3.5±0.5s 但し、ピンに異常加圧無き事。 /However, excessive pressure shall not be applied to the terminal.</p>	<p>実使用上の問題無き事 Should not have any problems.</p>

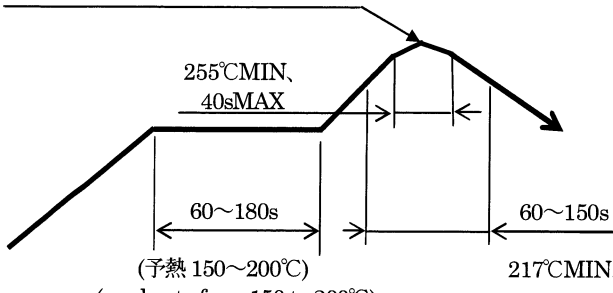
項目/Item	条件/Test condition	規格/Specification
3 半田耐熱性-2 (JEDEC LEVEL1) Soldering heat test-2 (JEDEC LEVEL1)	下記条件にて、半田耐熱性試験を行う。(JEDEC LEVEL1) The connector shall be tested resistance to soldering heat in the following conditions.(JEDEC LEVEL1) 吸水条件/ water absorption ・ ベーキング処理/baking: 125±5℃、24h ・ 吸水/water absorption: 85℃、85%RH、168h 条件①：リフローの場合（3回）/In case of reflow (3times) 260℃(ピーク温度/Peak temperature)  温度は製品上面の温度とする。 The temperature shall be measured on the surface of the product. 条件②：手半田の場合/In case of manual soldering. 半田温度/Solder iron : 350±5℃ 時間/time : 3.5±0.5s	実使用上の問題無き事 Should not have any problems.
4 温度上昇試験 Raise of temperature test	最大許容電流を通電し、熱伝対法にてコネクタの温度上昇を測定する。 The connector shall be operated in the maximum raise of current and measured raise of the temperature at contact point.	温度上昇：30℃以下 Raise of temperature : 30℃ or below

6. 製品の保管期限
製造日より1年とする。

6. Term of guarantee
1 year from product day.

7. 保存保管条件
室温で-10~+40℃の温度、75%RH以下の相対湿度で保管して下さい。

7. Storage conditions
Shall be storanged in the house at -10~+40℃、75%RH or less.

8. 推奨温度プロファイル 

8. Recommended temperature profile

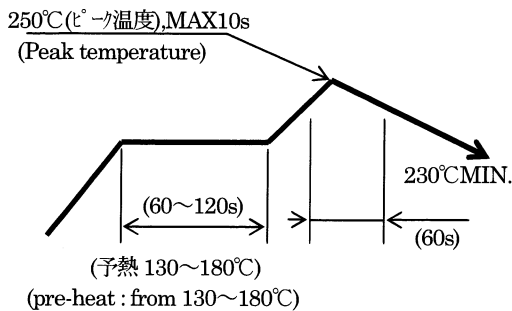

適用条件/Condition

- リフロー方式 / Reflow : 遠赤熱風併用リフロー / IR/hot air (日本パルス製 / Japan pulse RF-460)
- リフロー炉雰囲気 / Environment : 大気 / Room air
- ソルダーペースト / Solder paste : M705-GRN360-K2-V (千住金属製 / Senju Metal)
- ソルダー組成 / Solder composition : Sn3.0Ag0.5Cu
- メタルマスク厚/Metal mask thickness : t=0.12 (開口率/Open aperture ratio : 95~100%)
- 試験基板 / Test board : ガラスエポキシ / Glass epoxy 寸法 / Size100X100X1.6mm
- 基板のソリ : コネクタ実装部 0.02MAX.

この温度プロファイルは上記の適用条件のもので、使用クリームはんだの種類や塗布量、使用機器、基板寸法等の条件により異なる場合がありますので貴社実装状態をご確認の上、使用をお願いします。

This temperature profile is based on the above conditions. Individual applications the actual temperature may vary, depending on solder paste type, solder volume/thickness and board size/thickness. Consult your solder paste and equipment manufacture for specific recommendations.

FPC/FFC 用コネクタ

Connector for FPC/FFC

取り扱い説明書

Manual

適用製品：12001 シリーズ

Application product: series 12001

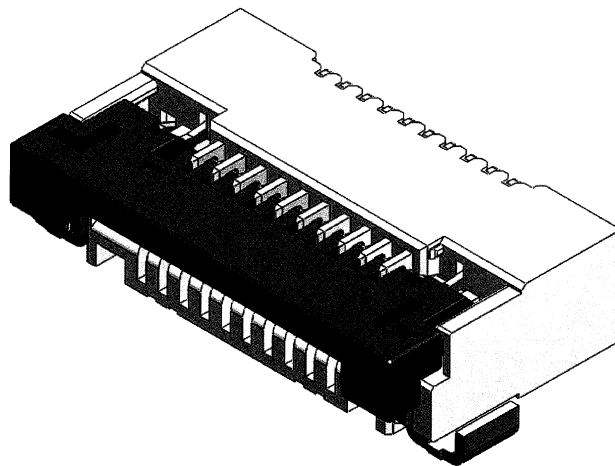

操作方法

FPC/FFC 挿入方法 FPC/FFC insertion

- ①カバーを上方向に開けて下さい。
(カバーは回転動作をします)

pull up the cover to open up.
(the cover will rotate to operate)

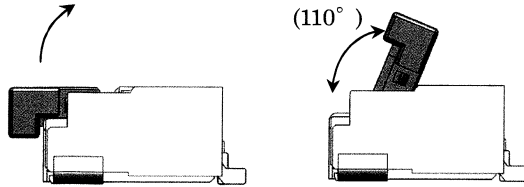

- ②FPC/FFCはコジらず、真直ぐ挿入してください。
壁にぶつかる感覚があるまで、押し込んでください。

Please insert FPC/FFC straight.
Please push it until it has the sense that runs up against a stone wall.

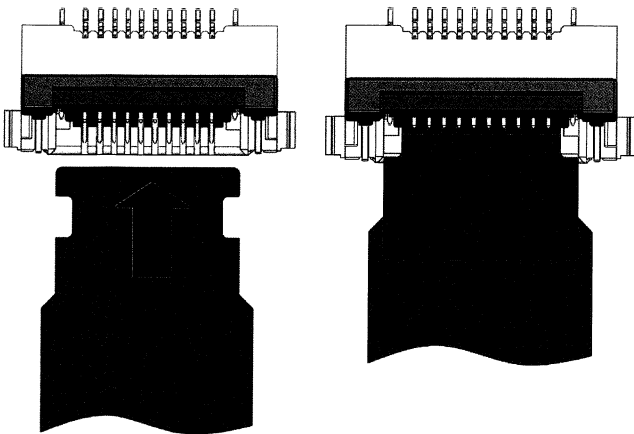

挿入量はFPC/FFCの切かきが、ハウジング内に入り込んだ状態を目安としてください。

Please give the state entering it to me as a standard in the housing of ..cutting form of FPC/FFC.

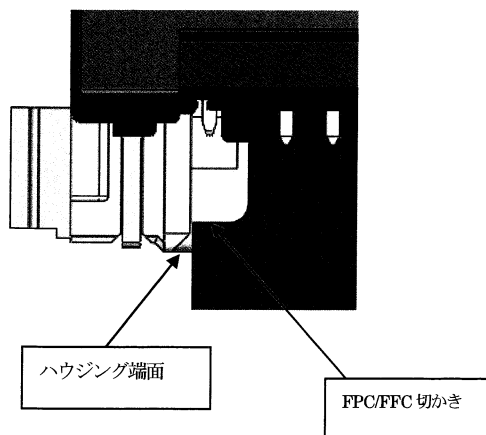

使用上の注意点

カバーは 110° 以上開かない構造の為、更に後ろへ強い力を加えないで下さい。変形・破損する事があります。

The cover is structured not to open more than 110° , so please don't add a strong force backward. It can be deformed and damaged.

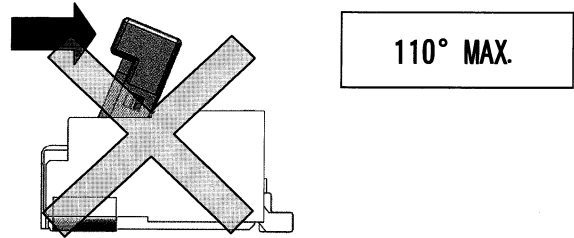

斜めに挿入したり、こじって挿入しますと、半嵌合又は、接点へのダメージの原因となり、接触不良が発生する恐れがございます。

The terminal transformation happens when FPC/FFC is diagonally inserted.

And, the loose connection happens.

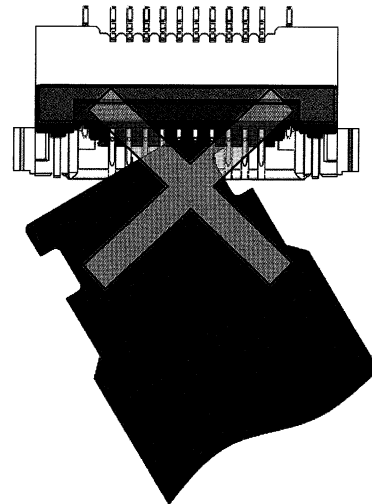

③カバーを閉じる際は、できるだけカバーの全面を押してください。
Please push all aspects of the cover when you shut the cover

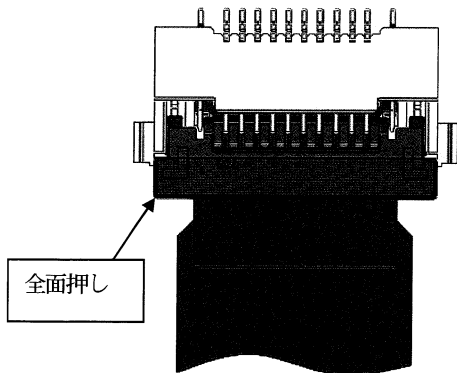

④カバーと基板が平行になるまで、押してください。
Please push until the cover becomes parallel to the PCB.

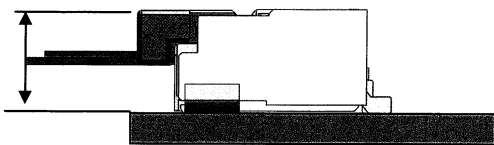

FPC/FFC 抜去方法 FPC/FFC decunting

①FPC/FFC 挿入時同様、カバーを上方向へ開けてください。
カバーを操作する際は、両手で操作してください。
(特に多極の場合)
Please open similar and the cover for above when you insert FPC/FFC.
Please operate it by both hands when you operate the cover.
(Especially, for the multipole)

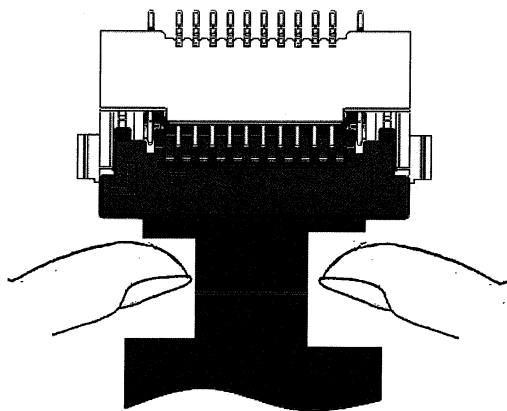

多極に於いての両端及び中央のみの操作は、破損や接触不良の原因となります。
The operation only of both ends and the center causes damage and the loose connection.

仮保持機能がございますので、指で FPC/FFC を押えないでください。
FPC/FFC が抜けてしまう恐れがございます。
(どうしても押える場合は、コネクタ端面より 20mm 以上離れた位置を押えてください)
Please do not hold FPC/FFC by the finger.
FPC/FFC might come off.
(Please suppress a position left from the connector edge side by 20mm or more when suppressing it.)

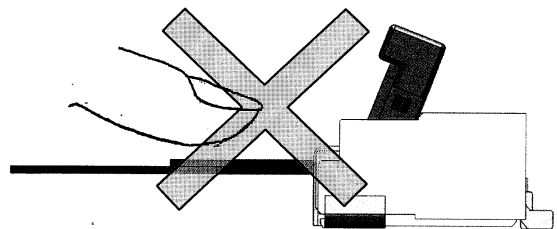

片手での操作は集中荷重がかかり、コネクタの破損に繋がります。
The operation by one hand leads to the damage of the connector.

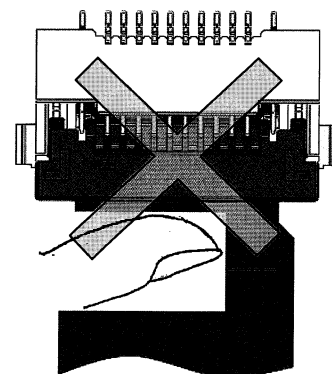

②FPC/FFCは真直ぐ引抜いてください。
 (引抜き角度は10°以下としてください)
 Please pull out FPC/FFC straight.
 (Please give the pulling out angle to me as 10° or less.)

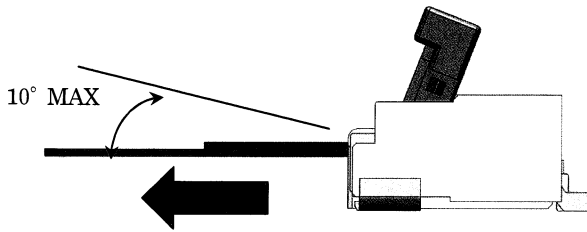

上方方向に引抜きますと、コネクタが破損に繋がります。
 The connector leads to damage when pulling it out for above.

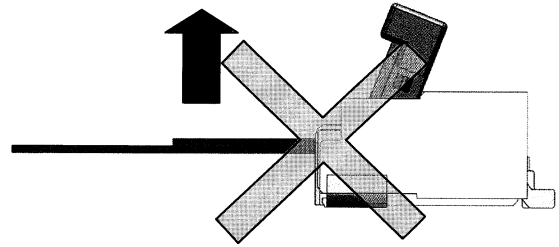

その他 Others

- ①コネクタ実装後、半田接合部が変色する場合がございますが
 使用上問題ございません。
 There is no problem in use though the solder joint part might
 discolor after mounting the connector.
- ②モールド内に黒点が発生する場合がございますが、性能上
 問題ございません。
 There is no problem on the performance though the black spot
 might be generated in molding.
- ③リフロー半田付け時、モールドに膨れが発生することが
 ございますが、性能上問題ございません。
 There is no problem on the performance though the swelling
 might be generated in molding when the reflow solder is put up.
- ④異種金属嵌合は、行わないでください。
 Please do not do the different kind metal mating.
- ⑤カード挿入口前に、カードの姿勢が変わるような部品を
 配置しないでください。
 Please do not arrange parts into which the posture of the card
 changes in the card insertion entrance front.
- ⑥反転リフロー時に製品が落下する可能性がございますので
 テープ等で補強することを推奨致します。
 Since a product may fall at the time of reversal reflow,
 I recommend reinforcing on a tape etc.