

**FineAdjust
Applicator**

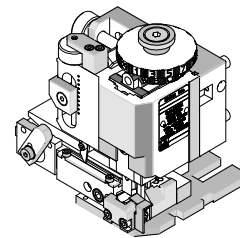

**Application Tooling
Specification Sheet**



Order No. 63900-4000

FEATURES

- Directly adapts to most automatic wire processing machines
- Quick punch removal with the push of a button for fast and easy tooling change
- Applicator designed to industry standard mounting and shut height 135.80mm (5.346")
- Quick set-up time; plus the crimp height, track and feed adjustments can be set without removing the applicator from the press
- Fine adjustment allows users to achieve target with little effort by adjusting in increments of .015mm (.0006") for conductor crimp height and .063mm (.0025") for insulation height
- Independent adjustment rings allow users to quickly adjust the conductor or insulation crimp height without affecting each other

SCOPE

Products: 2.00mm (.079") Pitch Micro Blade Board -In Crimp Terminal 26-30 AWG.

Terminal Series No.	Terminal Order No.	Wire Size		Insulation Diameter		Strip Length	
		AWG	mm ²	mm	In.	mm	In.
50034	50034-8000	26-30	0.12-0.05	0.80-1.40	.031-.055	1.40-1.90	.055-.075

DEFINITION OF TERMS

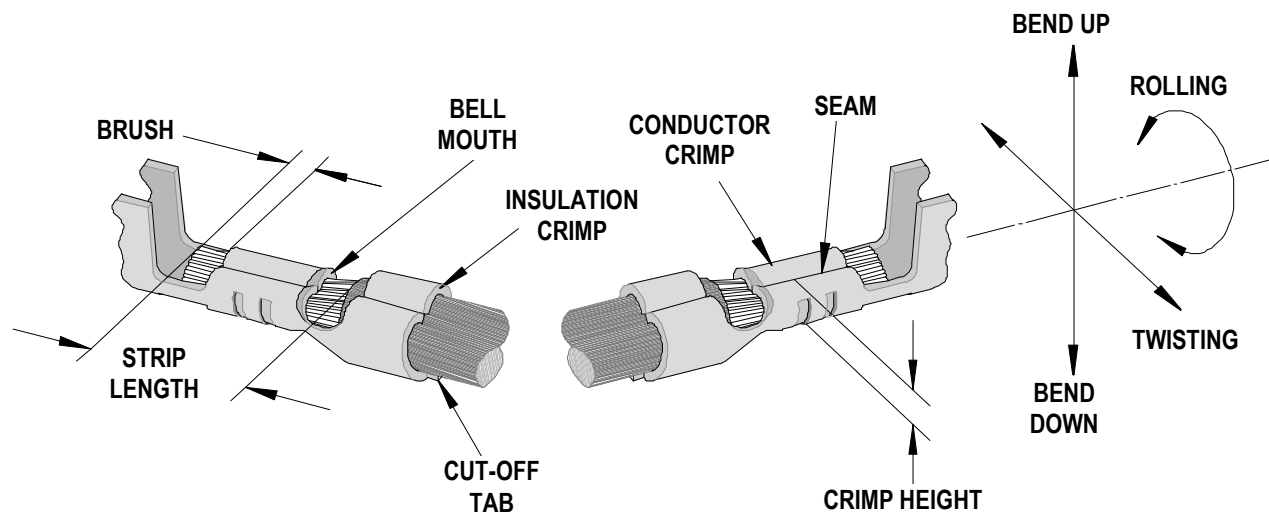

The above terminal drawing is a generic terminal representation. It is not an image of a terminal listed in the scope.

INSULATION CRIMP FORM

This crimp terminal is designed for miniaturization; therefore, each dimension of insulation crimp portion appears small as compared to the terminal material thickness. In order to avoid insulation piercing the crimp forms by the insulation barrel, coining is provided inside of the insulation barrel. For this reason, various crimp forms will occur at the tip of the insulation crimp barrel shown in the figure below.

These crimp forms maybe changed completely by a small change in the wire, insulation punch, or terminal.

These crimp forms are satisfactory for original function of the insulation crimp portion and it is confirmed that all of these forms below are acceptable insulation crimps.

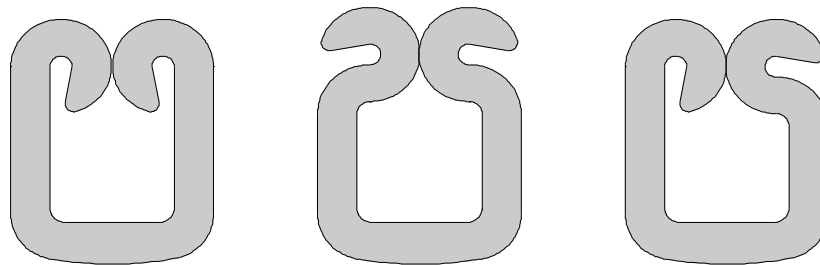

CRIMP SPECIFICATION

Terminal Series No.	Bell mouth		Cut-off Tab Maximum		Conductor Brush	
	mm	In.	mm	In.	mm	In.
50034	0.05-0.30	.002-.012	0.20	.008	0.00-0.70	.000-.028

Terminal Series No.	Bend up	Bend down	Twist	Roll	Punch Width mm (Ref)				Seam Seam shall not be open and no wire allowed out of the crimping area
	Degree		Degree		Conductor		Insulation		
	mm	In	mm	In	mm	In	mm	In	
50034	4	3	4	8	1.00	.039	1.40	.055	

After crimping, the conductor profile should measure the following.

Terminal Series No.	Wire Size		Conductor Crimp Height		Pull Force Minimum	
	AWG	mm ²	mm	In.	N	Lb.
50034	26	0.12	0.57-0.62	.022-.024	19.57	4.40
	28	0.08	0.56-0.61	.022-.024	9.78	2.20
	30	0.05	0.53-0.58	.021-.023	4.89	1.10

Pull Force should be measured with no influence from the insulation crimp.

The above specifications are guidelines to an optimum crimp.

PARTS LIST

FineAdjust Applicator 63900-4000				
Item	Order No	Engineering No.	Description	Quantity
Perishable Tooling				
	63900-4070	63900-4070	Tool Kit (All "Y" Items)	REF
1	63444-1003	63444-1003	Conductor Punch	1 Y
2	63445-1010	63445-1010	Conductor Anvil	1 Y
3	63446-1402	63446-1402	Insulation Punch	1Y
4	63445-1404	63445-1404	Insulation Anvil	1 Y
5	63443-0003	63443-0003	Cut-Off Plunger	1 Y
6	63443-0012	63443-0012	Front Plunger Retainer	1 Y
Other Components				
7	11-17-0022	1739-21	Hold Down Spring	1
8	11-18-4083	60707-8	Feed Guide	1
9	11-24-1067	4996-4	Cut-Off Plunger Spring	1
10	11-40-4039	8302-5	Plunger Striker	1
11	63443-0009	63443-0009	Front Scrap Chute	1
12	63443-0024	63443-0024	Key	1
13	63443-0090	63443-0090	Wire Stop	1
14	63443-0093	63443-0093	Shank	1
15	63443-1703	63443-1703	Height Spacer (17.30mm)	1
16	63443-2217	63443-2217	Coarse Spacer (17.00mm)	1
17	63443-2306	63443-2306	Fine Spacer (3.30mm)	1
18	63443-6111	63443-6111	Rear Cover	1
19	63900-4007	63900-4007	Terminal Hold Down	1
Frame				
20	63800-4901	63800-4901	Top	1
21	63801-3281	63801-3281	Base	1
22	63801-4650	63801-4650	Track	1
Hardware				
23	N/A	N/A	M3 by 6 Long SHCS	2**
24	N/A	N/A	M3 by 6 Long FHCS	1**
25	N/A	N/A	M3 by 8 Long SHCS	1**
26	N/A	N/A	M4 by 6 Long SHCS	2**
27	N/A	N/A	M4 by 12 Long BHCS	2**
28	N/A	N/A	M4 by 45 Long SHCS	2**
29	N/A	N/A	M5 by 12 Long SHCS	1**
30	N/A	N/A	#10-32 by 3/8" Long Flat Point SSS	1**
31	N/A	N/A	#10-32 Hex Jam Nut	1**

** Available from an industrial supply company such as MSC (1-800-645-7270).

Assembly Drawing

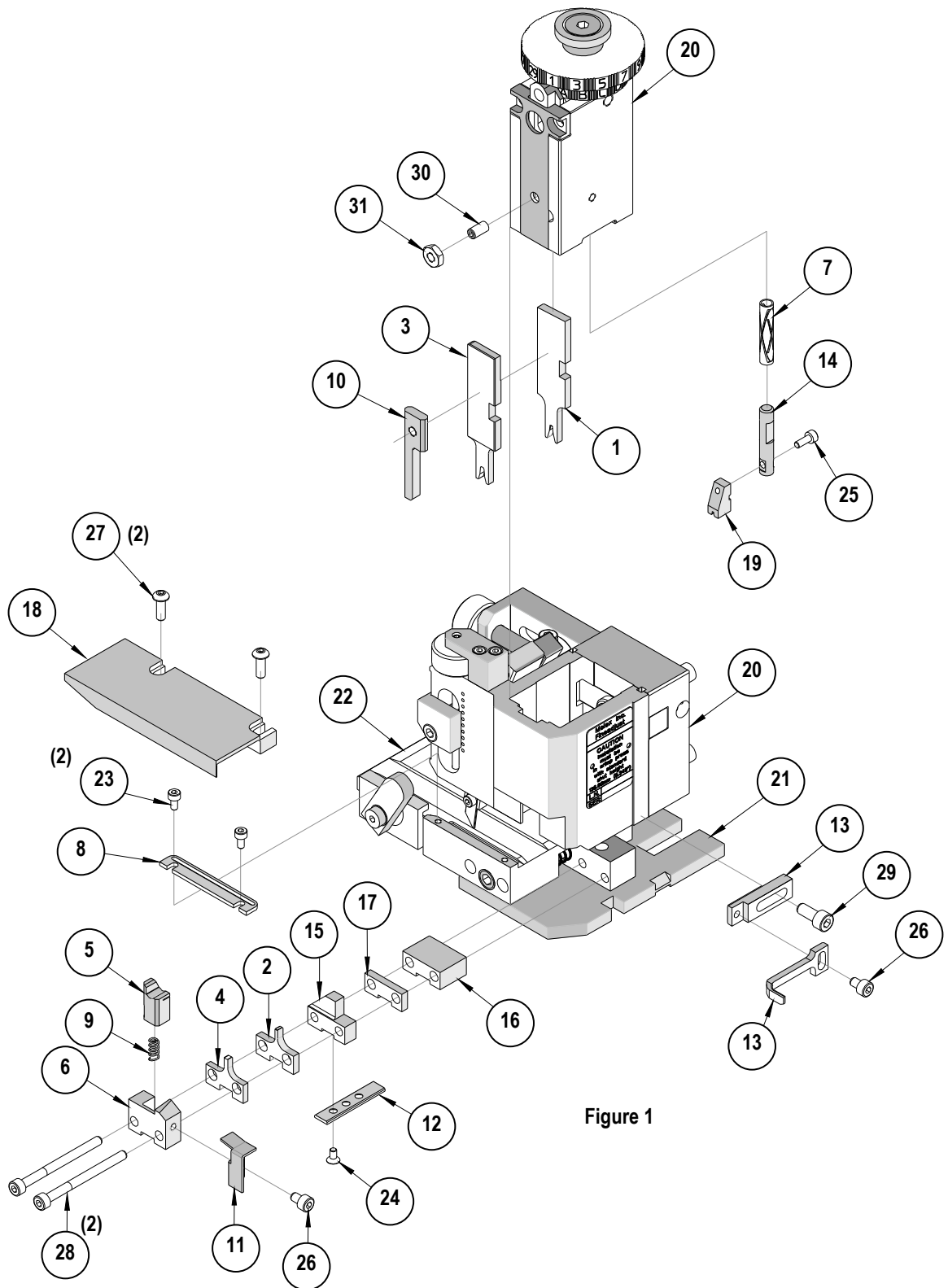

NOTES

1. Molex recommends an extra perishable tooling kit be maintained at your facility.
2. Verify tooling alignment by manually cycling the press and Applicator before crimping under power. Check that all screws are tight.
3. Slugs, Terminals, Dirt and Oil should be kept clear of work area.
4. Wear safety glasses at all times.
5. For recommended maintenance refer to the FineAdjust Manual.

CAUTION: This applicator should only be used in a press with a shut height of 135.80 mm (5.346"). Tooling damage could result at a lower setting.

CAUTION: To prevent injury never operate this Applicator without the guards supplied with the press or wire-processing machine in place. Reference the press or wire processing manufacturer's instruction manual.

CAUTION: Molex crimp specifications are valid only when used with Molex terminals, applicators and tooling.

Application Tooling Support
2200 Wellington Court
Lisle, IL 60532 USA
Phone: +1-402-458-TOOL (8665)
E-mail: applicationtooling@molex.com

Visit our Website at www.molex.com/applicationtooling