

SSL - Horizontal Plug

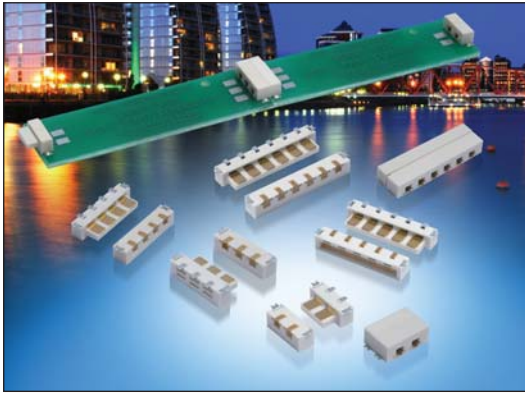

Series 9159



The 9159 series of Board-to-Board interconnect system allows two PCB's to be mated end-to-end creating strips of LED lighting. Designed specifically for the unique Solid State Lighting (SSL) market requiring coplanar (horizontal-to-horizontal) PCB mating with a 5 Amp current rating in the smallest package available. These single sided SMT connectors are perfect for both FR4 and metal boards where you need to butt the boards up together to minimize separation. Availability of both white and black insulation colors make them perfect for lighting as well as industrial applications. With sizes from 2p-6p, these high reliability connectors boast gold plated beryllium copper receptacle contacts for harsh environments.

Additional components in the 9159 product family include:

- SSL - Cabled Plug; Supports wire-to-board applications (11-9159)
- SSL - Horizontal Socket; Standard 2-Piece solution (20-9159)
- SSL - Top Load Socket; ZIF style for field reparability (22-9159)
- SSL - Shorting Socket; Two position (58-9159)
- SSL - Retaining Clip; Latches BTB connectors together (80-9159)

APPLICATIONS

- Coplanar PCB mating in SSL products
- LED linear lighting strips
- Application Notes; refer to 201-01-123

FEATURES AND BENEFITS

- Single sided SMT; supports FR4 and metal PCB's
- 5 Amp current rating; exceeds general market needs
- 5.5mm mated width; minimizes PCB space to decrease LED pitch
- Gold plated BeCu spring contacts; reliability for harsh environments
- Optional retaining clip; provides positive connector mating during vibration
- Available in white; supports SSL market preferences

ELECTRICAL

- Current Rating: 5 Amps / Contact
- Voltage Rating: 125 VAC

ENVIRONMENTAL

- Operating Temperature: -40°C to +125°C

MECHANICAL

- Insulator Material: Nylon: VL94VO
- Contact Material: BeCu / Phos Bronze
- Plating: Gold / Tin over Nickel
- Durability: 10 Cycles

HOW TO ORDER

10	9159	XXX	1	01	X	16																																
Plug	Series	Number of Ways	2 Part PCB Strip Connector	Connector Pitch 01 = 3mm	Insulator Color	Plating Option																																
		<table border="1"> <thead> <tr> <th>Code</th> <th>No of Ways</th> <th>Details</th> </tr> </thead> <tbody> <tr> <td>002</td> <td>2</td> <td>Page 3</td> </tr> <tr> <td>003</td> <td>3</td> <td>Page 4</td> </tr> <tr> <td>004</td> <td>4</td> <td>Page 5</td> </tr> <tr> <td>005</td> <td>5</td> <td>Page 6</td> </tr> <tr> <td>006</td> <td>6</td> <td>Page 7</td> </tr> </tbody> </table>	Code	No of Ways	Details	002	2	Page 3	003	3	Page 4	004	4	Page 5	005	5	Page 6	006	6	Page 7		<table border="1"> <thead> <tr> <th>Code</th> <th>Color</th> <th>Application</th> </tr> </thead> <tbody> <tr> <td>0</td> <td>Black</td> <td>Industrial</td> </tr> <tr> <td>1</td> <td>White</td> <td>Lighting</td> </tr> </tbody> </table>	Code	Color	Application	0	Black	Industrial	1	White	Lighting	<table border="1"> <thead> <tr> <th>Code</th> <th>Contact</th> <th>Bracket</th> </tr> </thead> <tbody> <tr> <td>16</td> <td>Gold in Contact Area Tin on Solder Tail</td> <td>Tin all over</td> </tr> </tbody> </table>	Code	Contact	Bracket	16	Gold in Contact Area Tin on Solder Tail	Tin all over
Code	No of Ways	Details																																				
002	2	Page 3																																				
003	3	Page 4																																				
004	4	Page 5																																				
005	5	Page 6																																				
006	6	Page 7																																				
Code	Color	Application																																				
0	Black	Industrial																																				
1	White	Lighting																																				
Code	Contact	Bracket																																				
16	Gold in Contact Area Tin on Solder Tail	Tin all over																																				
		Optional Retaining Clip Page 8																																				



SSL - Horizontal Plug



Series 9159

PLUG 2 WAY 2 PART PCB STRIP CONNECTOR

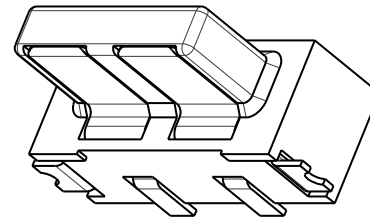
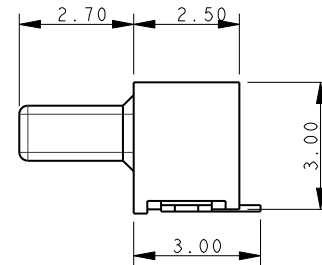
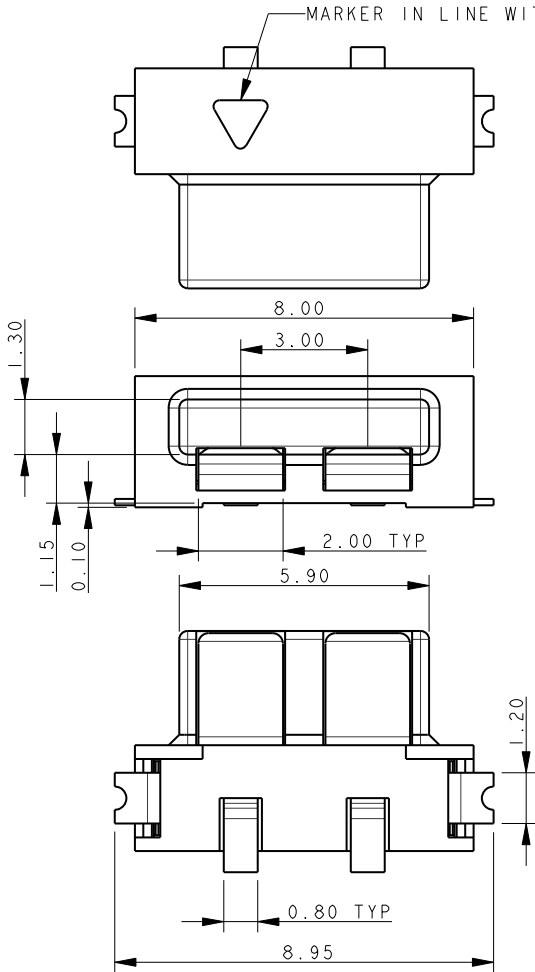

NOTES:

1. FOR MORE INFORMATION REFER TO PRODUCT SPEC 201-01-119.
2. DIMENSIONS ARE REFERENCE DIMENSIONS UNLESS TOLERANCES.
3. INSULATOR MATERIAL: NYLON 46.
4. CONTACT MATERIAL: COPPER ALLOY, SELECTIVE GOLD OVER NICKEL TIN PLATED ON TAILS.
5. BRACKETS: COPPER ALLOY, TIN PLATED.
6. OUTLINE OF CONNECTOR.
7. PACKING TAPE AND REEL, QUANTITY 1400 PER REEL.
8. OPTIONAL RETAINING CLIP, SEE PAGE 8.

2 WAY PCB BOARD LAYOUT

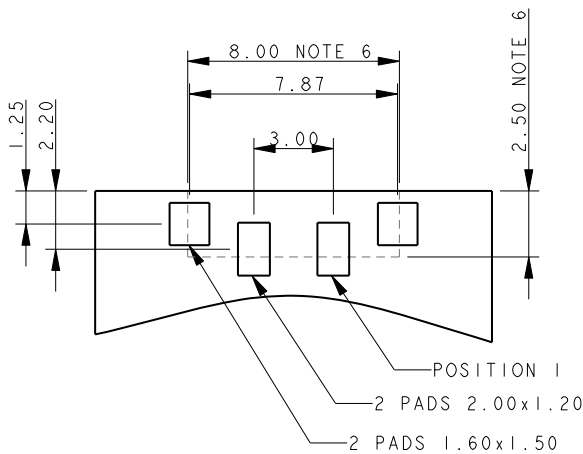

PACKING DETAILS

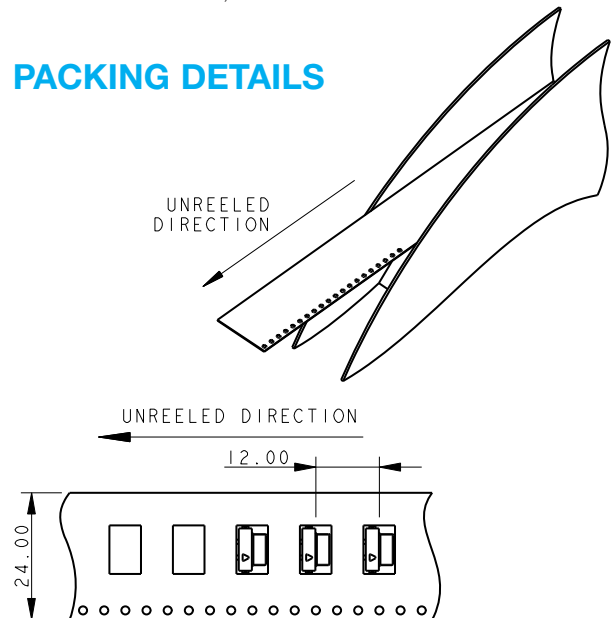

SSL - Horizontal Plug



Series 9159

PLUG 3 WAY 2 PART PCB STRIP CONNECTOR

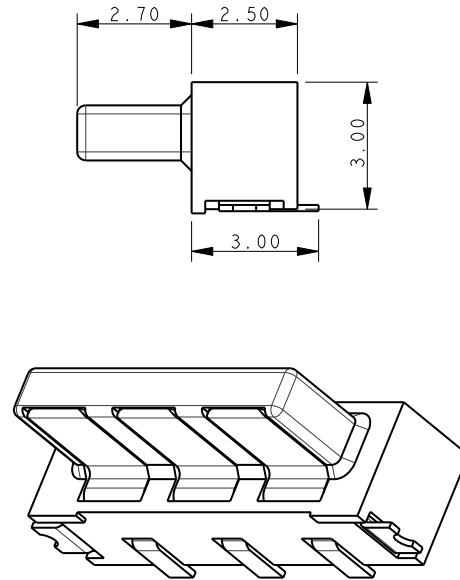
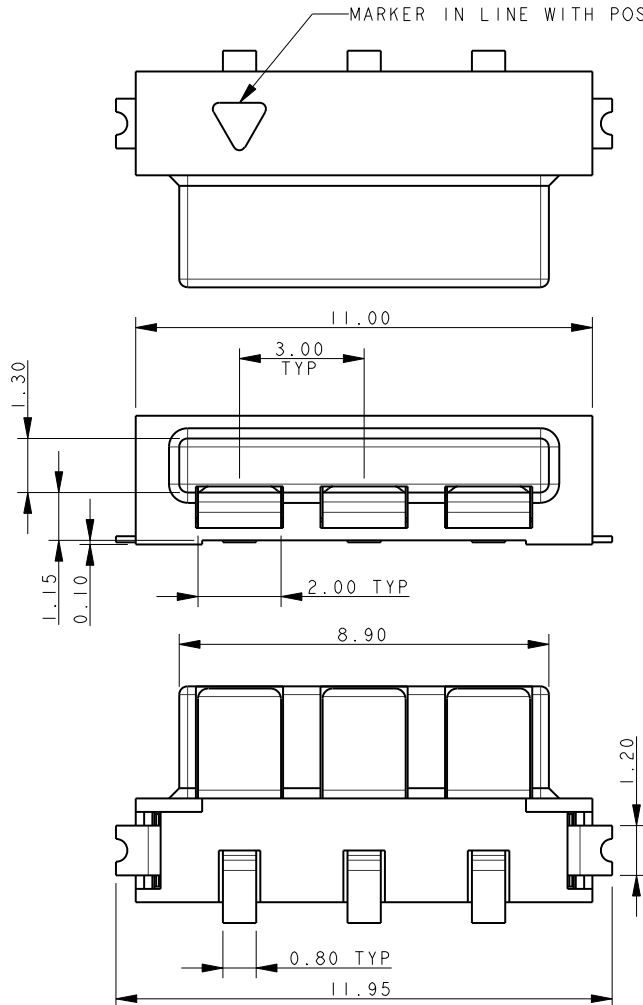

NOTES:

1. FOR MORE INFORMATION REFER TO PRODUCT SPEC 201-01-119.
2. DIMENSIONS ARE REFERENCE DIMENSIONS UNLESS TOLERANCES.
3. INSULATOR MATERIAL: NYLON 46.
4. CONTACT MATERIAL: COPPER ALLOY, SELECTIVE GOLD OVER NICKEL TIN PLATED ON TAILS.
5. BRACKETS: COPPER ALLOY, TIN PLATED.
6. OUTLINE OF CONNECTOR.
7. PACKING TAPE AND REEL, QUANTITY 1400 PER REEL.
8. OPTIONAL RETAINING CLIP, SEE PAGE 8.

3 WAY PCB BOARD LAYOUT

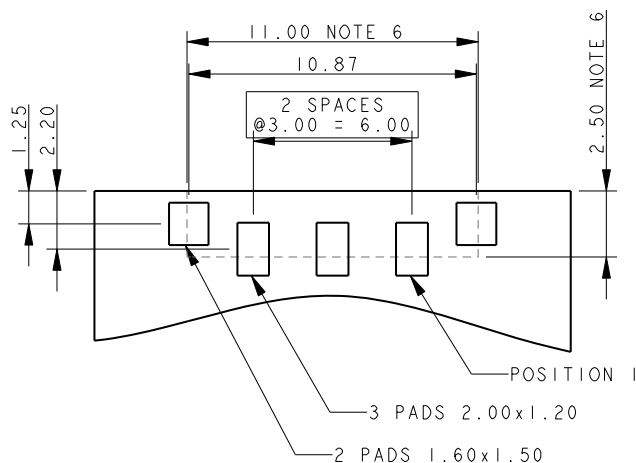

PACKING DETAILS

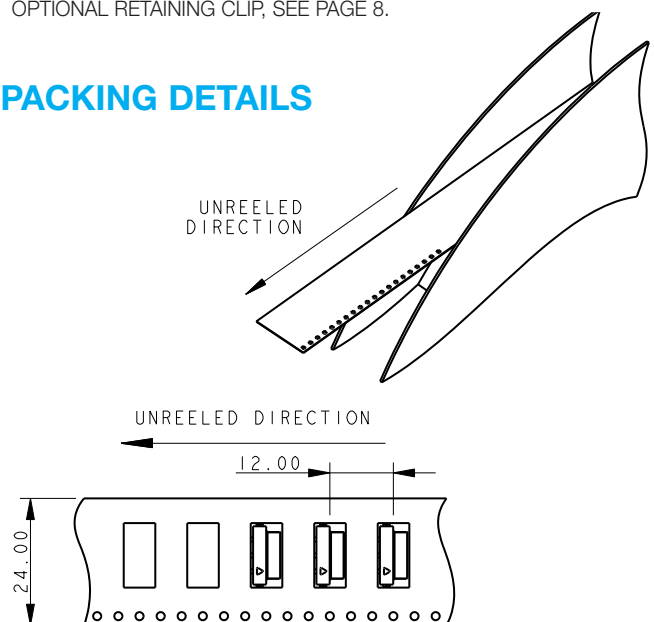

SSL - Horizontal Plug



Series 9159

PLUG 4 WAY 2 PART PCB STRIP CONNECTOR

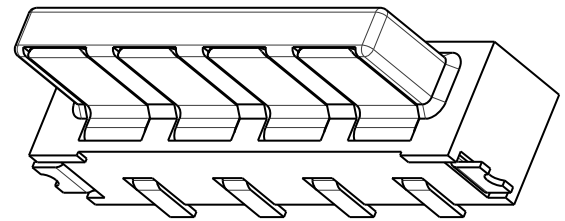
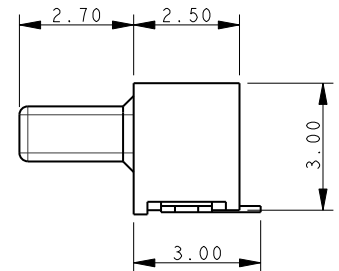
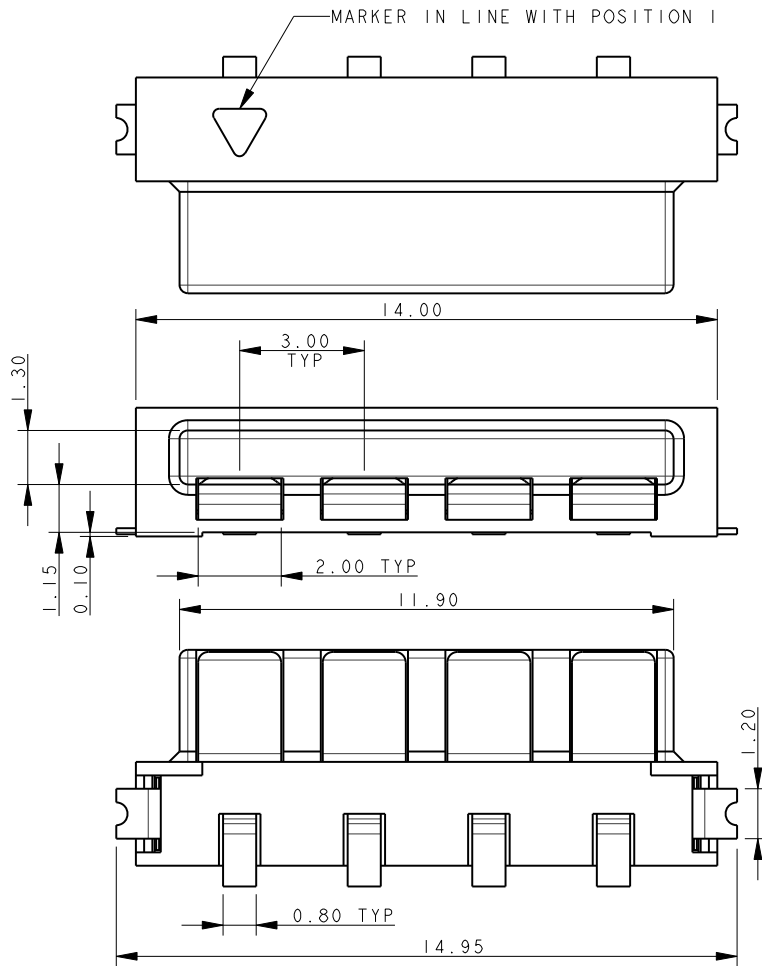

NOTES:

1. FOR MORE INFORMATION REFER TO PRODUCT SPEC 201-01-119.
2. DIMENSIONS ARE REFERENCE DIMENSIONS UNLESS TOLERANCES.
3. INSULATOR MATERIAL: NYLON 46.
4. CONTACT MATERIAL: COPPER ALLOY, SELECTIVE GOLD OVER NICKEL TIN PLATED ON TAILS.
5. BRACKETS: COPPER ALLOY, TIN PLATED.
6. OUTLINE OF CONNECTOR.
7. PACKING TAPE AND REEL, QUANTITY 1400 PER REEL.
8. OPTIONAL RETAINING CLIP, SEE PAGE 8.

4 WAY PCB BOARD LAYOUT

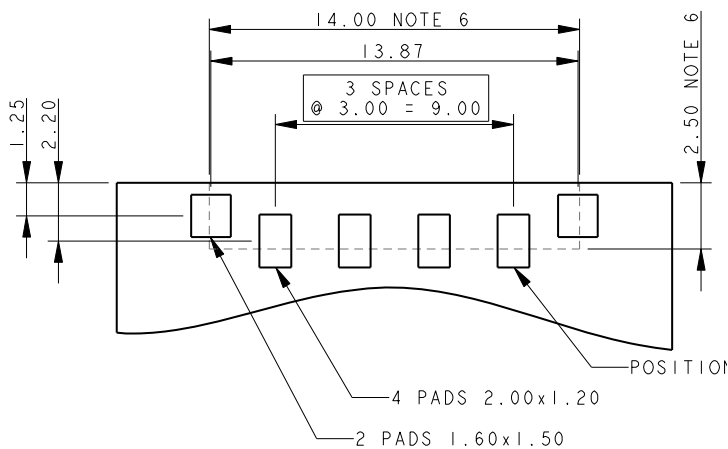

PACKING DETAILS

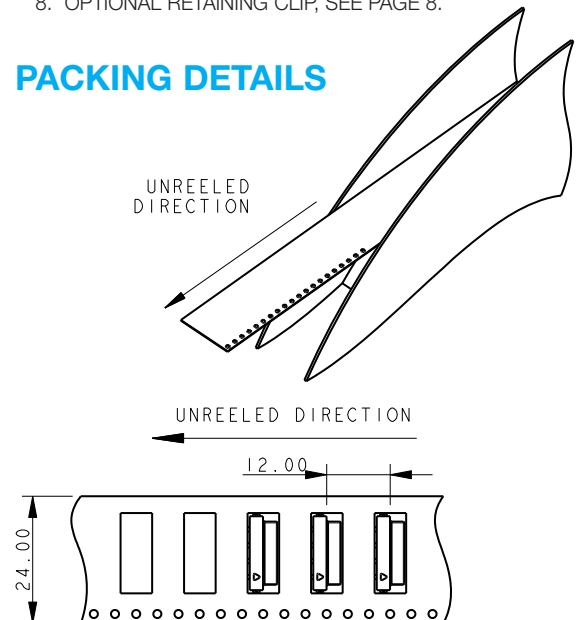

SSL - Horizontal Plug



Series 9159

PLUG 5 WAY 2 PART PCB STRIP CONNECTOR

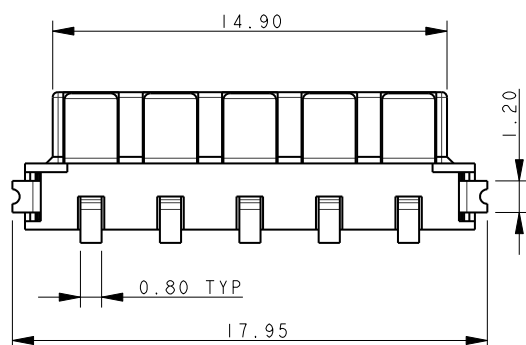
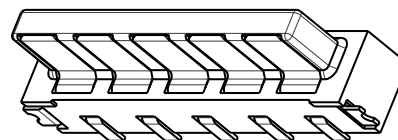
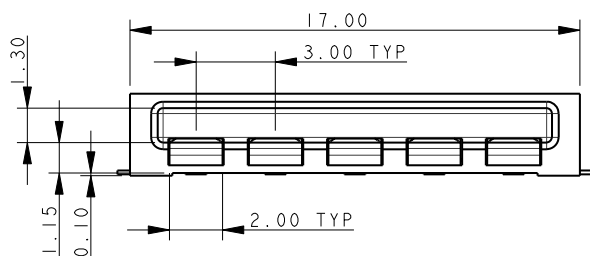
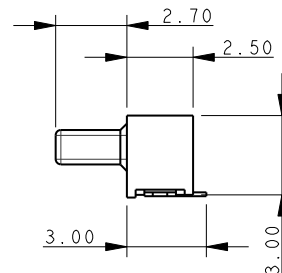
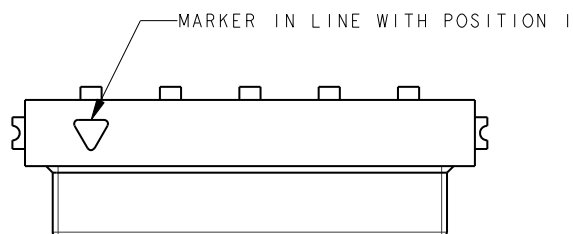

NOTES:

1. FOR MORE INFORMATION REFER TO PRODUCT SPEC 201-01-119.
2. DIMENSIONS ARE REFERENCE DIMENSIONS UNLESS TOLERANCES.
3. INSULATOR MATERIAL: NYLON 46.
4. CONTACT MATERIAL: COPPER ALLOY, SELECTIVE GOLD OVER NICKEL TIN PLATED ON TAILS.
5. BRACKETS: COPPER ALLOY, TIN PLATED.
6. OUTLINE OF CONNECTOR.
7. PACKING TAPE AND REEL, QUANTITY 1400 PER REEL.
8. OPTIONAL RETAINING CLIP, SEE PAGE 8.

5 WAY PCB BOARD LAYOUT

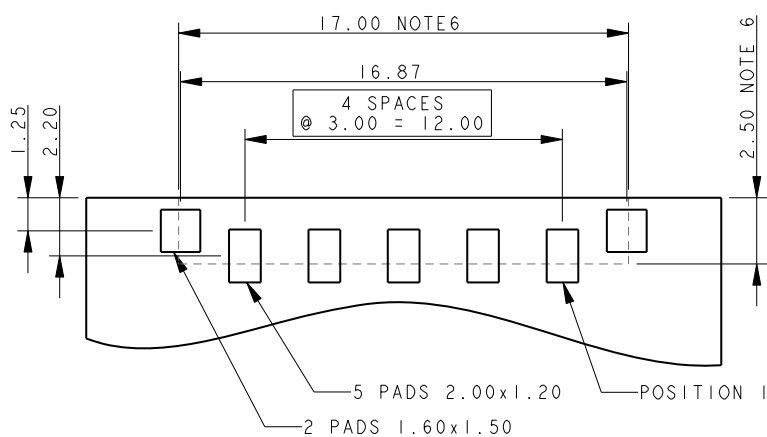

PACKING DETAILS

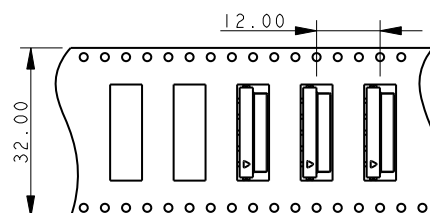
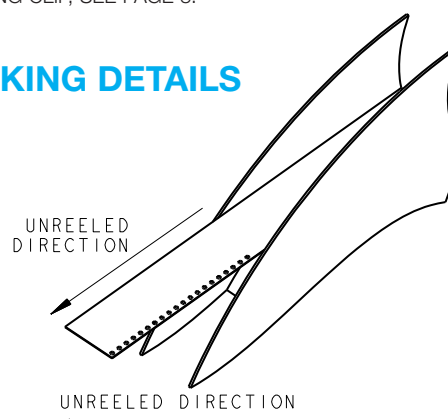

SSL - Horizontal Plug

Series 9159



PLUG 6 WAY 2 PART PCB STRIP CONNECTOR

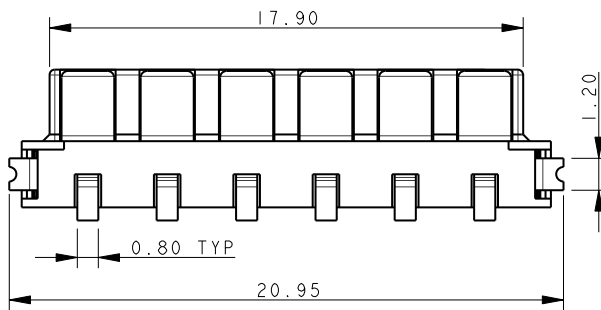
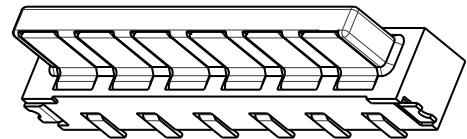
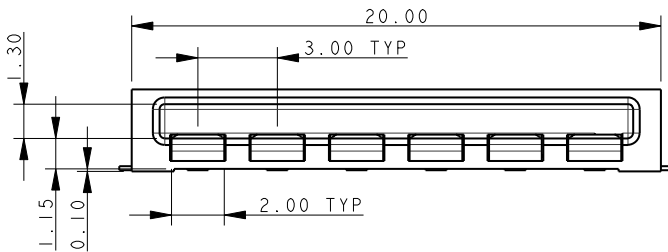
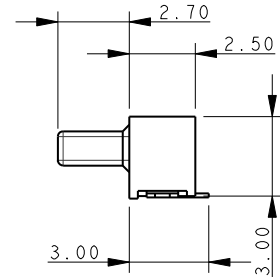
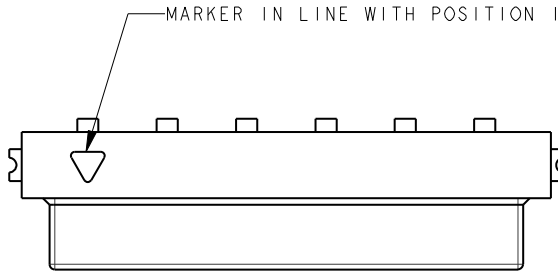

NOTES:

1. FOR MORE INFORMATION REFER TO PRODUCT SPEC 201-01-119.
2. DIMENSIONS ARE REFERENCE DIMENSIONS UNLESS TOLERANCES.
3. INSULATOR MATERIAL: NYLON 46.
4. CONTACT MATERIAL: COPPER ALLOY, SELECTIVE GOLD OVER NICKEL TIN PLATED ON TAILS.
5. BRACKETS: COPPER ALLOY, TIN PLATED.
6. OUTLINE OF CONNECTOR.
7. PACKING TAPE AND REEL, QUANTITY 1400 PER REEL.
8. OPTIONAL RETAINING CLIP, SEE PAGE 8.

6 WAY PCB BOARD LAYOUT

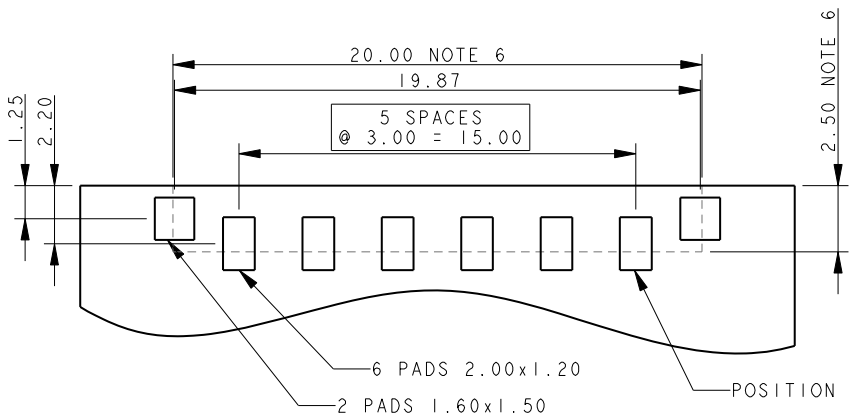

PACKING DETAILS

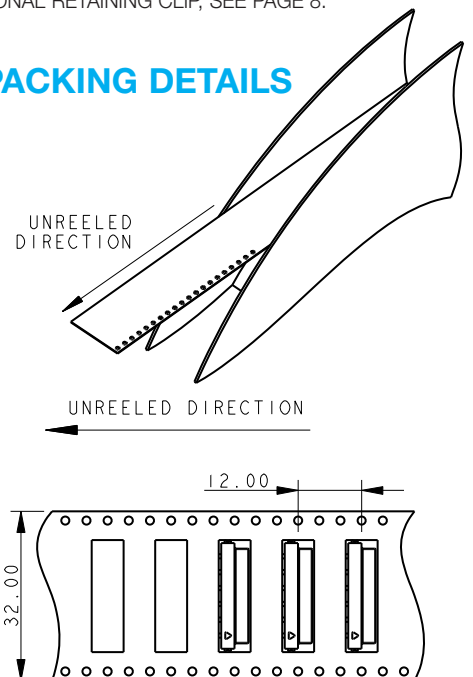

SSL - Horizontal Plug



Series 9159

80-9159-4200-00-000 ACCESSORY RETAINING CLIP

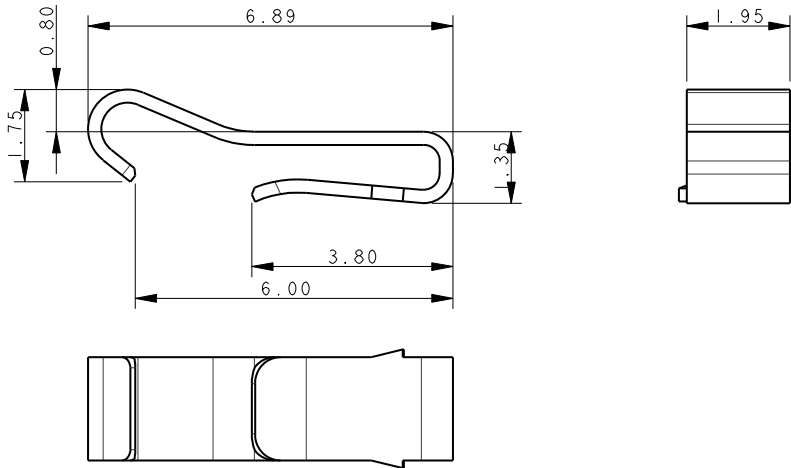

PLUG ASSEMBLY – FOR REFERENCE ONLY

CLIP INSERTED INTO 10-9159-00X-101-X06

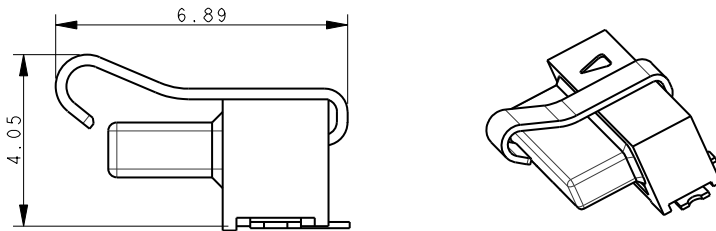

HAND INSERTION TOOL

06-9159-7025-01-000

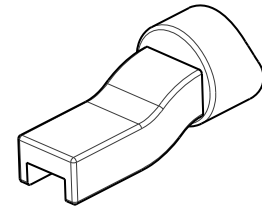

MATED ASSEMBLY – FOR REFERENCE ONLY

10-9159-00X-101-X06 MATED WITH 20-9159-00X-X06

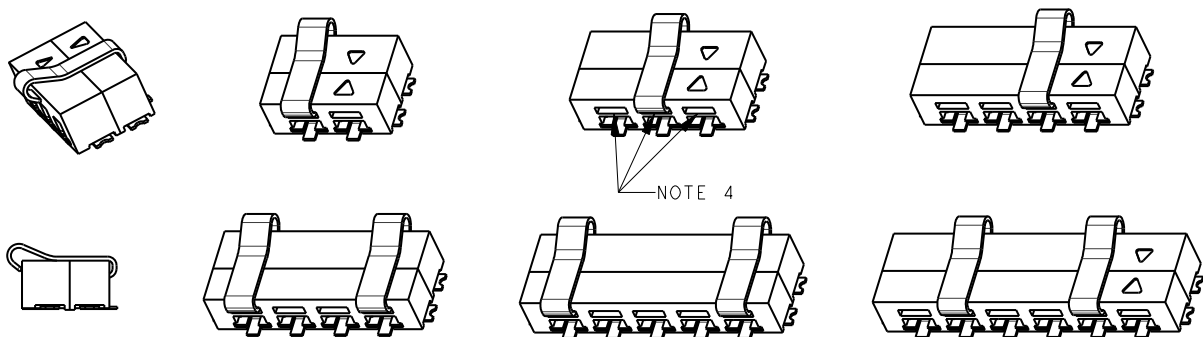

NOTES:

1. CLIP TO RETAIN MATED PAIR PLUG AND SOCKET. NOT SUPPLIED WITH CONNECTOR.
2. MATERIAL: STAINLESS STEEL.
3. PACKING IN BAGS, 1400 PER BAG.
4. TAIL INSERTED INTO SLOT OF 9159 2 PART PLUG (10-9159-00X-101-006). LEADING EDGE CLIPS OVER SOCKET.
5. ALL DIMENSIONS SHOWN ARE REFERENCE DIMENSIONS.
6. RECOMMENDED 1 CLIP IN 2, 3 AND 4 WAY. 2 CLIPS IN 5 AND 6 WAY. POSITIONS AT CUSTOMER DISCRETION.

Mouser Electronics

Authorized Distributor

Click to View Pricing, Inventory, Delivery & Lifecycle Information:

[AVX:](#)

[069159702602000](#)