

PART NUMBER	REVISION	DESCRIPTION	FEED TYPE
2151353-1	L	FINE CRIMP HEIGHT ADJUST	MECHANICAL
2151353-2	L	FINE CRIMP HEIGHT ADJUST	PNEUMATIC
7-2151353-1	L	MECHANICAL AND CRIMP TOOLING KIT	MECHANICAL
7-2151353-2	L	PNEUMATIC AND CRIMP TOOLING KIT	PNEUMATIC
7-2151353-7	L	CRIMP TOOLING KIT	-

ATLANTIC VERSION TERMINATOR INTERFACE ADAPTER



APPLICATOR DATA		
CRIMP	SIZE	TYPE
WIRE	1.78 mm [.070]	F
INSUL	2.29 mm [.090]	BX

APPLICATOR INSTRUCTIONS
408-35042

TERMINAL DATA: TE TERMINAL		TE CRIMP SPECIFICATION	
TERMINAL NAME: MCON 1.2 LL			
WIRE STRIP LENGTH		INSULATION DIAMETER RANGE	
3.30-3.90 mm [.130-.154 IN]		1.90-2.40 mm [.075-.094 IN]	
TERMINAL APPLICATION SPECIFICATION	114-18464		
TERMINALS APPLIED ⁵			
TE TERMINAL	TE TERMINAL	TE TERMINAL	TE TERMINAL
1452659-1	1452659-2	1452659-3	
7-1452659-1	7-1452659-2	7-1452659-3	

WIRE SIZE	CRIMP HEIGHT mm [INCH]	CRIMP HEIGHT REFERENCE SETTING
1.50mm2	1.31+/-0.05 [.052+/-0.002]	8.0
16 AWG	1.26+/-0.05 [.050+/-0.002]	8.5
1.00mm2	1.10+/-0.05 [.043+/-0.002]	10.0
18 AWG	1.05+/-0.05 [.041+/-0.002]	10.6

- ¹ RECOMMENDED SPARE PARTS
 - ² REFER TO SUPPLIED INSTRUCTION SHEET FOR CLEANING, LUBRICATION AND STORAGE OF APPLICATOR.
 - ³ APPLY PART NUMBER 2-23419-6 LOCTITE TO THREADS OF ITEM 242.
 - ⁴ CRIMP HEIGHT REFERENCE SETTING WAS THE SETTING USED WHEN THE APPLICATOR WAS QUALIFIED AT THE FACTORY. ADJUSTMENT MAY BE NECESSARY WHEN RUNNING APPLICATOR IN THE FIELD.
 - ⁵ TERMINAL LUBRICANT IS RECOMMENDED.
6. UNLESS SPECIFIED OTHERWISE TORQUE VALUES SHALL BE USED PER DOCUMENT, 101-35000.

***WARNING**
ON INSTALLATION, SET WIRE DISC TO CRIMP HEIGHT REFERENCE SETTING FOR LARGEST WIRE SIZE. CRIMP HEIGHT REFERENCE SETTINGS GREATER THAN THE VALUE SHOWN MAY CAUSE DAMAGE TO THE CRIMP TOOLING, REFER TO THE INSTRUCTION SHEET FOR PROPER SETUP AND ADJUSTMENTS.

ATLANTIC VERSION
Shown on sheets 1 of 4 & 2 of 4
(Pacific version shown on sheets 3 of 4 & 4 of 4)

LOC	DIST	REVISIONS					
A	66	P	LTN	DESCRIPTION	DATE	OWN	APVD
		J		ECR-18-006047	20APR2018	MEH	JDG
		K		ECR-19-005769	10APR2019	FJ	TE
		K1		ECR-21-005485	17MAY2021	AJ	YY
		L		ECR-22-147172	25JUL2022	LG	TE

-	1	-	1	-	2119641-1	FEED CAM, AIR FEED	248	
-	1	1	1	1	2119082-4	CAM, SNAIL, INSULATION ADJUSTMENT	244	
-	1	1	1	1	2079764-1	WASHER, WAVE SPRING, CREST-TO-CREST	243	
-	1	1	1	1	2119083-1	RETAINER, INSULATION DIAL	242	
-	1	1	1	1	7-18023-7	SCR, SKT HD CAP M3 X 4.0	241	
-	-	1	-	1	2119580-1	MECHANICAL FEED ASSEMBLY	239	
-	1	-	1	-	2844940-1	AIR FEED MODULE	238	
-	REF	REF	REF	REF	994970-2	COUNTER, MAGNETIC	164	
-	1	1	1	1	2119955-1	ASSY, LUBRICATOR, SIDE FEED	113	
-	1	1	1	1	2844908-1	SCREW, LOCKING	99	
-	1	1	1	1	2844907-1	POST, LOCKING	98	
-	1	1	1	1	455888-5	SPACER, CRIMPER	82	
-	1	1	1	1	22278-8	SPRING, COMPRESSION	77	
-	1	1	1	1	854769-4	HOLDER, INS	74	
-	1	1	1	1	1803607-3	DOCUMENTATION PACKAGE	71	
-	1	1	1	1	2119740-1	TAG, IDENTIFICATION	67	
-	2	2	2	2	2168078-1	SCREW, DRIVE, RH, RoHS, 2 x .188	66	
-	1	1	1	1	2168083-2	SCR, SKT HD CAP, RoHS, M4 X 8.0	60	
-	1	1	1	1	5-18022-5	SCR, HEX HD CAP, M4 X 6.0	59	
-	1	1	1	1	21028-2	PIN, SLOTTED SPRING .062 X .250	58	
-	1	1	1	1	1338685-1	PAWL, FEED	56	
-	4	4	4	4	2168083-3	SCR, SKT HD CAP, RoHS, M4 X 12.0	54	
-	2	2	2	2	1-2168083-0	SCR, SKT HD CAP, RoHS, M4 X 10	53	
-	1	2	1	2	18023-9	SCR, SKT HD CAP M4 X 6.0	49	
-	-	1	-	1	2119652-1	FEED CAM, PRE FEED	48	
-	-	1	-	1	2119653-1	FEED CAM, POST FEED	47	
-	1	1	1	1	1803583-9	APPLICATOR BASIC ASSEMBLY, SF	46	
-	1	1	1	1	1803515-1	RAM ASSEMBLY, SF ATLANTIC	44	
-	1	1	1	1	1803602-1	SCR, BHSC, RoHS (M8 X 25)	41	
-	1	1	1	1	1752356-6	SUPPORT, TERMINAL	34	
-	2	2	2	2	2079383-5	SCR, BHSC, RoHS (M4 X 20)	33	
-	2	2	2	2	2-2844962-6	SPACER, CYLINDRICAL, STRIP GUIDE	30	
-	1	1	1	1	2844992-2	ASSEMBLY, STRIP GUIDE	29	
-	1	1	1	1	455888-4	SPACER, CRIMPER	28	
-	1	1	1	1	1320928-2	STRIP GUIDE	24	
-	1	1	1	1	2168083-2	SCR, SKT HD CAP, RoHS, M4 X 8.0	21	
-	4	4	4	4	1-18028-2	WASHER, FLAT, REG M4	20	
-	1	1	1	1	2119533-1	STRIPPER, SIDE FEED	19	
-	1	1	1	1	1333264-1	HOLD DOWN	18	
-	1	1	1	1	2119806-1	INSERT, SHEAR	13	
-	1	1	1	1	3-22280-3	SPRING, COMPRESSION	12	
-	1	1	1	1	1-356885-4	STOP, SHEAR	11	
-	1	1	1	1	2119805-1	SHEAR HOLDER, FRONT	10	
-	1	1	1	1	1633861-1	SHEAR, FLOATING	9	
-	1	2	2	1	1	9-1333203-4	ANVIL, COMBINATION	8
-	-	-	-	-	-	-	7	
-	-	-	-	-	-	-	6	
-	1	1	1	1	1-2119780-1	DEPRESSOR, SHEAR	5	
-	1	1	1	1	4-238011-1	BLOCK, CRIMPER SPACER	4	
-	1	2	2	1	1	1633989-8	CRIMPER, INSULATION, SPECIAL	3
-	1	2	2	1	1	1633169-2	CRIMPER, WIRE, SPECIAL	1
-	77	-72	-71	-2	-1	PART NO	DESCRIPTION	ITEM NO

DIMENSIONS:		TOLERANCES UNLESS OTHERWISE SPECIFIED:		OWN: L. ZHANG 26 JUL 2012		CHK: L. ZHANG 26 JUL 2012		APVD: S. XI 26 JUL 2012		NAME: Ocean Side Feed Applicator	
mm	0 PLC ±	1 PLC ±	2 PLC ±	3 PLC ±	4 PLC ±	ANGLES ±	FINISH	WEIGHT	SCALE: 1:2	SHEET 1 OF 4	REV L
MATERIAL		FINISH		CAGE CODE		DRAWING NO		RESTRICTED TO		Customer Accessible Production Drawing	

LOC		DIST		REVISIONS			
P	LTN	DATE	DESCRIPTION	DATE	OWN	APVD	
-	-	-	SEE SHEET 1	-	-	-	-

FEED TYPE MECHANICAL

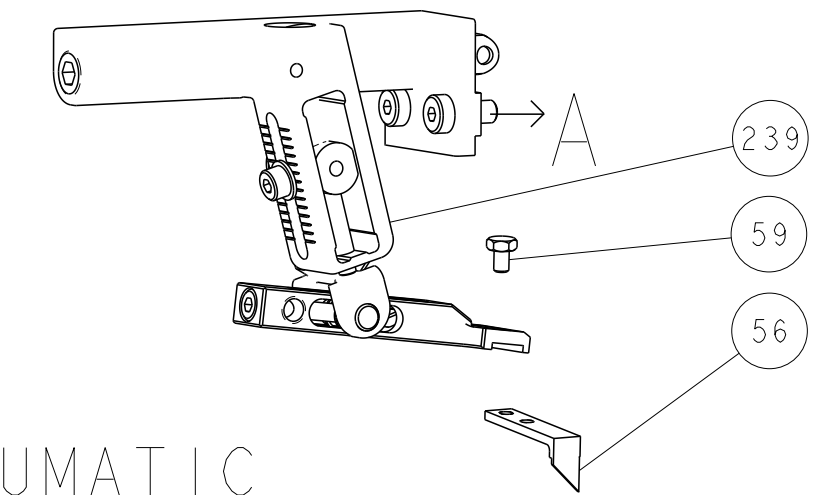

PNEUMATIC

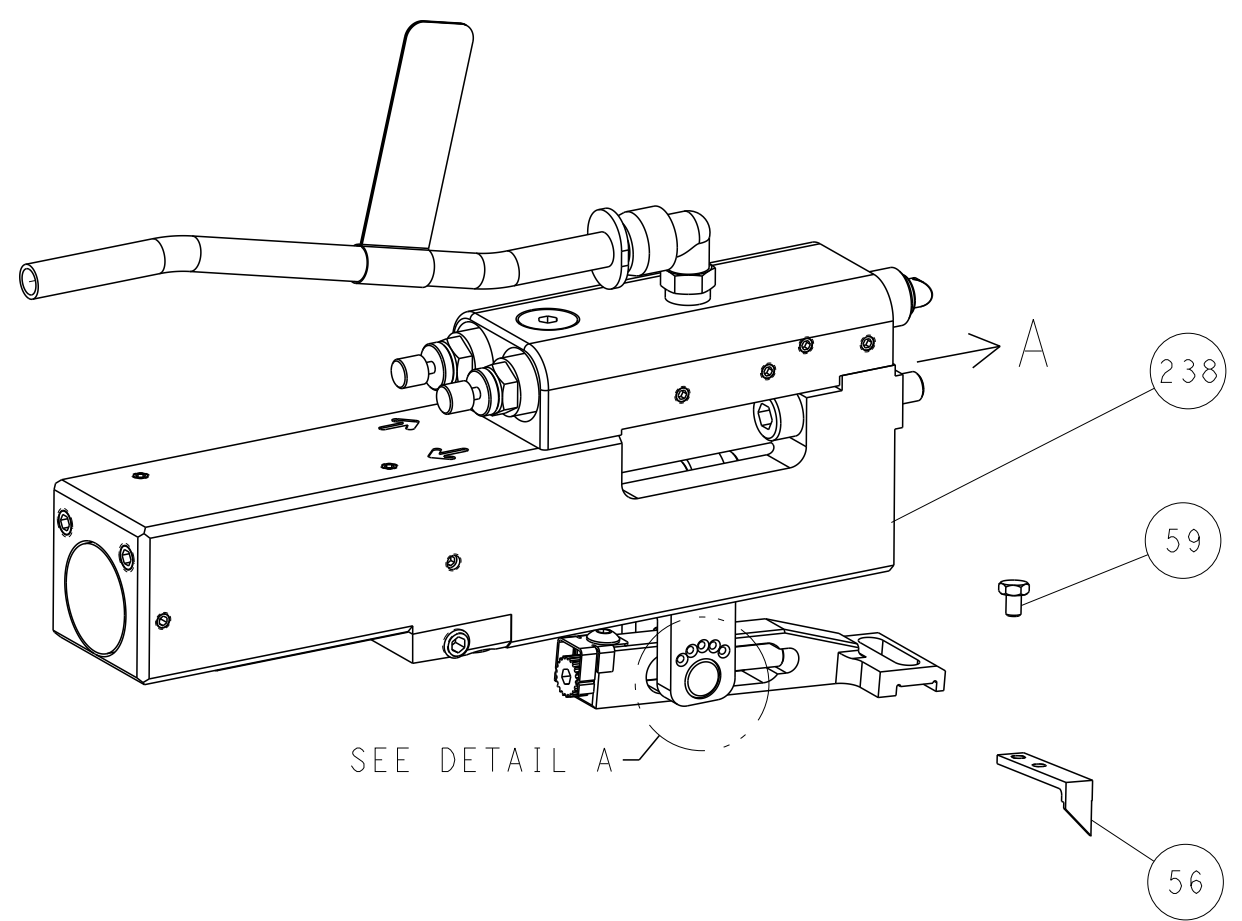

FEED SPRING SETTING POSITION (SHOWN FROM REAR SIDE)



DETAIL A

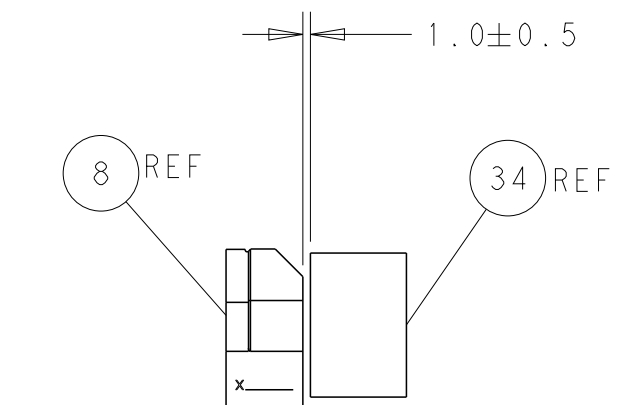
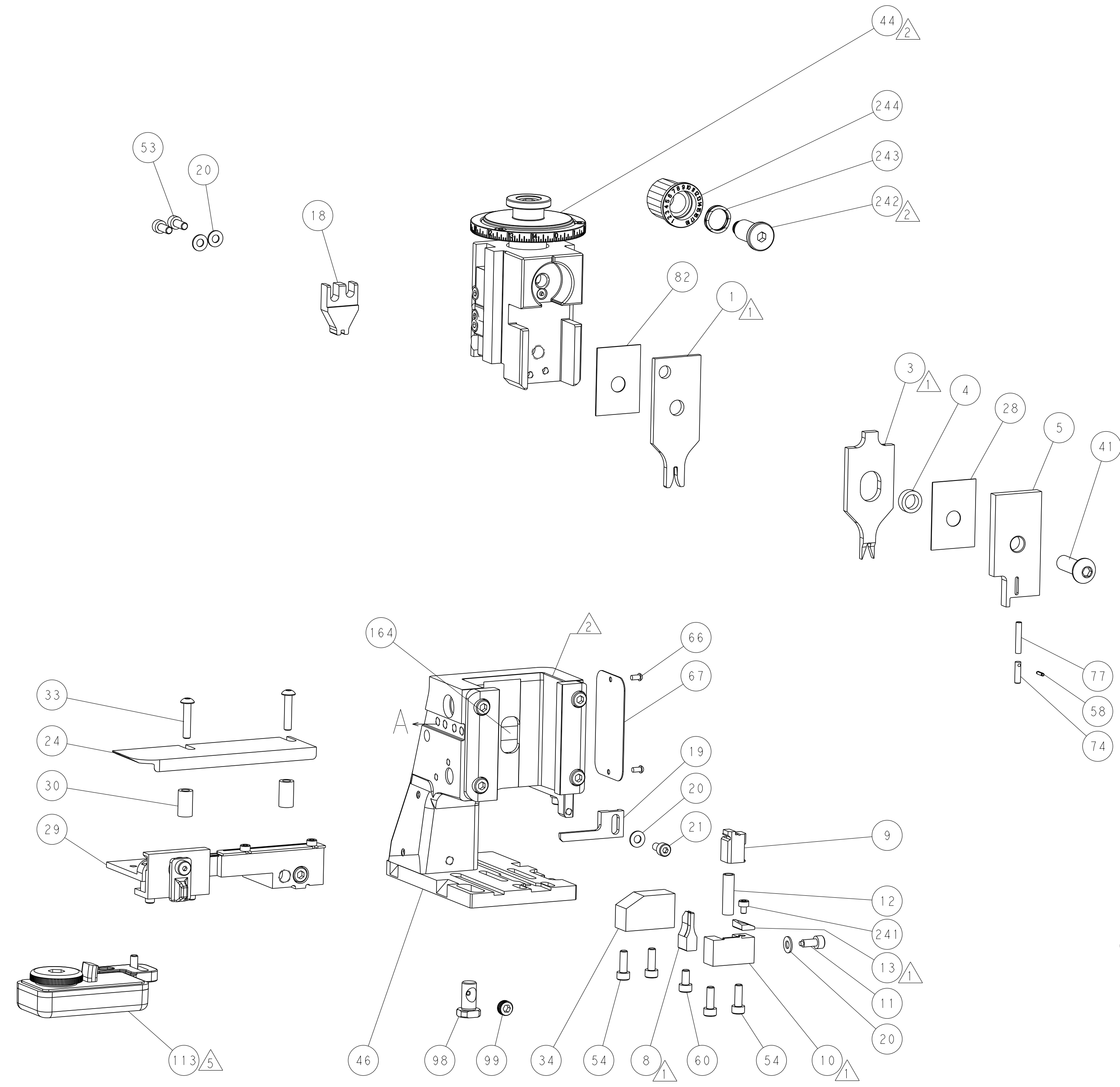

TERMINAL SUPPORT LOCATION

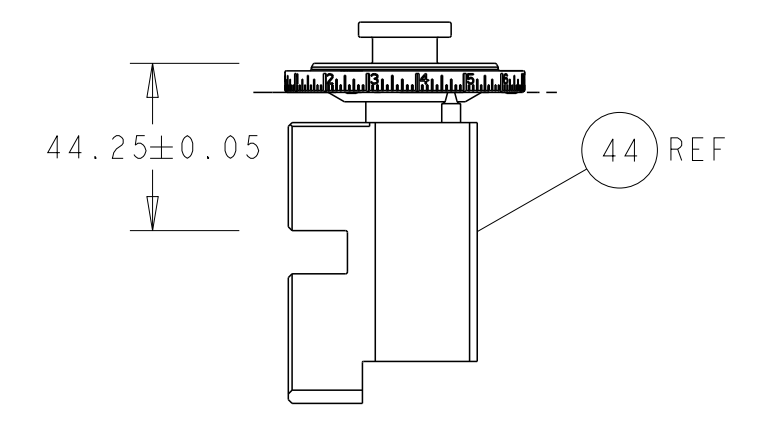

RAM SET-UP

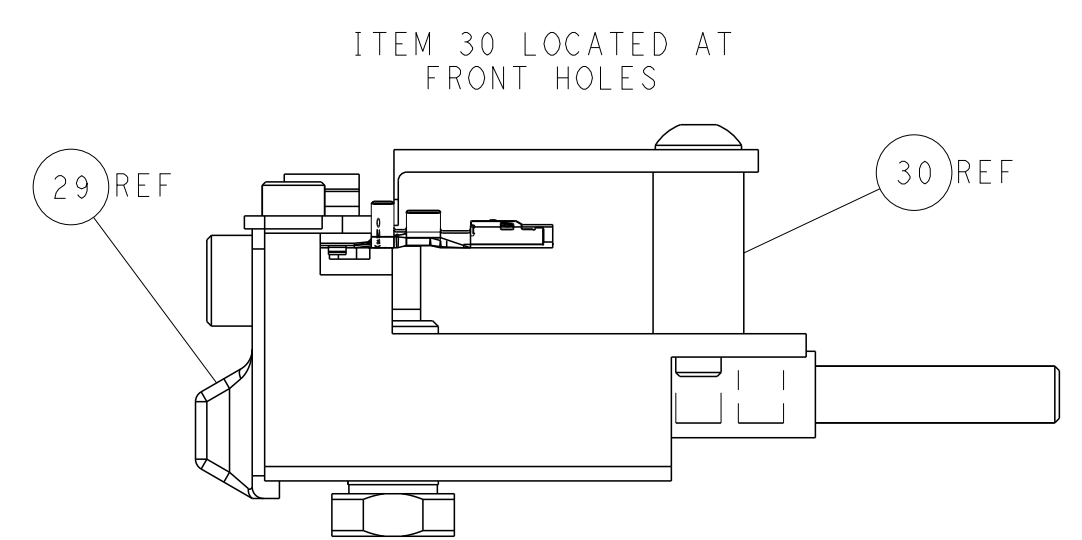

FEED TRACK POSITION GUIDE BY INSULATION BARREL

CAM POSITIONS

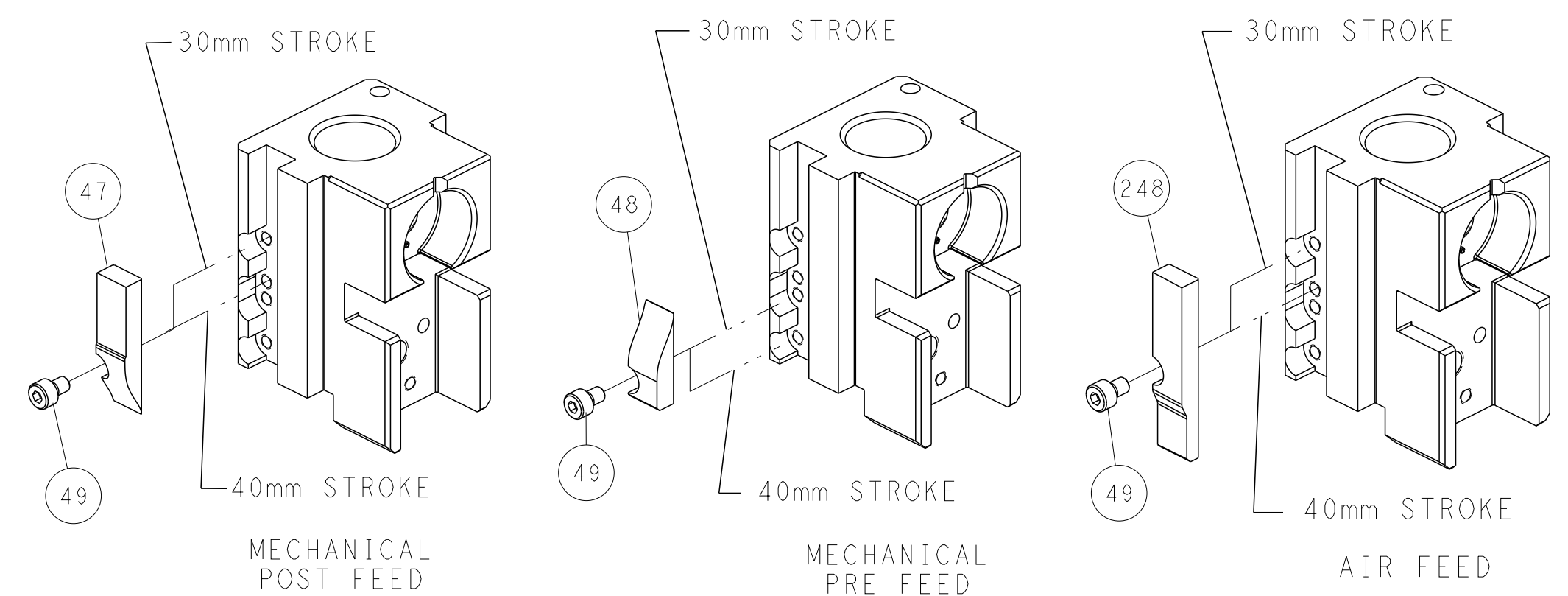

ATLANTIC VERSION
 Shown on sheets 1 of 4 & 2 of 4
 (Pacific version shown on sheets 3 of 4 & 4 of 4)

DIMENSIONS:		TOLERANCES UNLESS OTHERWISE SPECIFIED:		DWN L. ZHANG 26 JUL 2012		TE Connectivity Harrisburg, PA 17105-3608	
mm	0 PLC ±	1 PLC ±	2 PLC ±	3 PLC ±	4 PLC ±	NAME Ocean Side Feed Applicator	
MATERIAL:		FINISH:		APVD S. XI 26 JUL 2012		SIZE CAGE CODE DRAWING NO RESTRICTED TO	
				PRODUCT SPEC		A1 00779 ©=2151353	
				APPLICATION SPEC		Customer Accessible Production Drawing	
				WEIGHT		SCALE 1:2 SHEET 2 OF 4 REV L	

PART NUMBER	REVISION	DESCRIPTION	FEED TYPE
2-2151353-1	L	FINE CRIMP HEIGHT ADJUST	MECHANICAL
2-2151353-2	L	FINE CRIMP HEIGHT ADJUST	PNEUMATIC
7-2151353-7	L	CRIMP TOOLING KIT	-

PACIFIC VERSION TERMINATOR
 INTERFACE ADAPTER



APPLICATOR DATA		
CRIMP	SIZE	TYPE
WIRE	1.78 mm [.070]	F
INSUL	2.29 mm [.090]	BX
APPLICATOR INSTRUCTIONS 408-35042		

TERMINAL DATA: TE TERMINAL		TE CRIMP SPECIFICATION	
TERMINAL NAME: MCON 1.2 LL			
WIRE STRIP LENGTH 3.30-3.90 mm [1.30-.154 IN]		INSULATION DIAMETER RANGE Ø1.90-2.40 mm [.075-.094 IN]	
TERMINAL APPLICATION SPECIFICATION 114-18464			
TERMINALS APPLIED			
TE TERMINAL	TE TERMINAL	TE TERMINAL	TE TERMINAL
1452659-1	1452659-2	1452659-3	
7-1452659-1	7-1452659-2	7-1452659-3	

WIRE SIZE	CRIMP HEIGHT mm [INCH]	CRIMP HEIGHT REFERENCE SETTING
1.50mm2	1.31+/-0.05 [1.052+/-0.002]	8.0
16 AWG	1.26+/-0.05 [1.050+/-0.002]	8.5
1.00mm2	1.10+/-0.05 [1.043+/-0.002]	10.0
18 AWG	1.05+/-0.05 [1.041+/-0.002]	10.6



- 1 RECOMMENDED SPARE PARTS
- 2 REFER TO SUPPLIED INSTRUCTION SHEET FOR CLEANING, LUBRICATION AND STORAGE OF APPLICATOR.
- 3 APPLY PART NUMBER 2-23419-6 LOCTITE TO THREADS OF ITEM 242.
- 4 CRIMP HEIGHT REFERENCE SETTING WAS THE SETTING USED WHEN THE APPLICATOR WAS QUALIFIED AT THE FACTORY. ADJUSTMENT MAY BE NECESSARY WHEN RUNNING APPLICATOR IN THE FIELD.
- 5 TERMINAL LUBRICANT IS RECOMMENDED.
- 6. UNLESS SPECIFIED OTHERWISE TORQUE VALUES SHALL BE USED PER DOCUMENT, 101-35000.

***WARNING**
 ON INSTALLATION, SET WIRE DISC TO CRIMP HEIGHT REFERENCE SETTING FOR LARGEST WIRE SIZE. CRIMP HEIGHT REFERENCE SETTINGS GREATER THAN THE VALUE SHOWN MAY CAUSE DAMAGE TO THE CRIMP TOOLING, REFER TO THE INSTRUCTION SHEET FOR PROPER SETUP AND ADJUSTMENTS.

ENTRY LEVEL APPLICATOR		ITEM SUBSTITUTION LIST		
PART NUMBER	SAME AS	ITEM	ITEM DESCRIPTION	SUBSTITUTE PART NUMBER
8-2151353-1	2151353-1	1	WIRE CRIMPER	1803661-2
8-2151353-2	2151353-2	3	INSULATION CRIMPER	1803623-8
9-2151353-1	2-2151353-1	46	BASIC SUB -ASSEMBLY	1803940-9
9-2151353-2	2-2151353-2	141	BASIC SUB -ASSEMBLY	1-1803940-0
			LUBRICATOR	DELETE

PACIFIC VERSION
 Shown on sheets 3 of 4 & 4 of 4
 (Atlantic version shown on sheets 1 of 4 & 2 of 4)

LOC	DIST	REVISIONS					
A	66	P	LTN	DESCRIPTION	DATE	OWN	APVD
		-	-	SEE SHEET 1	-	-	-

-	1	1	2119082-4	CAM, SNAIL, INSULATION ADJUSTMENT	244	
-	1	1	2079764-1	WASHER, WAVE SPRING, CREST-TO-CREST	243	
3	-	1	1	2119083-1	RETAINER, INSULATION DIAL	242
-	1	1	7-18023-7	SCR, SKT HD CAP M3 X 4.0	241	
-	-	1	1	2119580-1	MECHANICAL FEED ASSEMBLY	239
-	1	-	2844940-1	AIR FEED MODULE	238	
-	REF	REF	994970-2	COUNTER, MAGNETIC	164	
-	1	-	2119641-2	FEED CAM, AIR FEED	151	
-	1	1	2168083-8	SCR, SKT HD CAP, RoHS, M4 X 16	144	
-	4	4	2168083-9	SCR, SKT HD CAP, RoHS, M4 X 20	143	
-	-	1	2119653-2	FEED CAM, POST FEED	142	
-	1	1	1-1803583-0	APPLICATOR BASIC ASSEMBLY, SF	141	
-	1	1	1803516-1	RAM ASSEMBLY, SF PACIFIC	140	
5	-	1	1	2119955-1	ASSY, LUBRICATOR, SIDE FEED	113
-	1	1	2844908-1	SCREW, LOCKING	99	
-	1	1	2844907-1	POST, LOCKING	98	
-	1	1	455888-5	SPACER, CRIMPER	82	
-	1	1	22278-8	SPRING, COMPRESSION	77	
-	1	1	854769-4	HOLDER, INS	74	
-	1	1	1803607-3	DOCUMENTATION PACKAGE	71	
-	1	1	2119740-1	TAG, IDENTIFICATION	67	
-	2	2	2168078-1	SCREW, DRIVE, RH, RoHS, 2 x .188	66	
-	1	1	5-18022-5	SCR, HEX HD CAP, M4 X 6.0	59	
-	1	1	21028-2	PIN, SLOTTED SPRING .062 X .250	58	
-	1	1	1338685-1	PAWL, FEED	56	
-	2	2	1-2168083-0	SCR, SKT HD CAP, RoHS, M4 X 10	53	
-	1	2	18023-9	SCR, SKT HD CAP M4 X 6.0	49	
-	-	1	2119652-1	FEED CAM, PRE FEED	48	
-	1	1	1803602-1	SCR, BHSC, RoHS (M8 X 25)	41	
-	1	1	1752356-6	SUPPORT, TERMINAL	34	
-	2	2	2079383-5	SCR, BHSC, RoHS (M4 X 20)	33	
-	2	2	2-2844962-6	SPACER, CYLINDRICAL, STRIP GUIDE	30	
-	1	1	2844992-2	ASSEMBLY, STRIP GUIDE	29	
-	1	1	455888-4	SPACER, CRIMPER	28	
-	1	1	1320928-2	STRIP GUIDE	24	
-	1	1	2168083-2	SCR, SKT HD CAP, RoHS, M4 X 8.0	21	
-	4	4	1-18028-2	WASHER, FLAT, REG M4	20	
-	1	1	2119533-1	STRIPPER, SIDE FEED	19	
-	1	1	133264-1	HOLD DOWN	18	
1	-	1	1	2119806-1	INSERT, SHEAR	13
-	1	1	3-22280-3	SPRING, COMPRESSION	12	
-	1	1	1-356885-4	STOP, SHEAR	11	
-	1	1	2119805-1	SHEAR HOLDER, FRONT	10	
-	1	1	1633861-1	SHEAR, FLOATING	9	
1	1	1	9-1333203-4	ANVIL, COMBINATION	8	
-	-	-	-	-	7	
-	-	-	-	-	6	
-	1	1	1-2119780-1	DEPRESSOR, SHEAR	5	
-	1	1	4-238011-1	BLOCK, CRIMPER SPACER	4	
1	1	1	1633989-8	CRIMPER, INSULATION, SPECIAL	3	
1	1	1	1633169-2	CRIMPER, WIRE, SPECIAL	1	
-	-	-	-77-22-21	PART NO	ITEM NO	

DIMENSIONS: mm		TOLERANCES UNLESS OTHERWISE SPECIFIED: 0 PLC ± 1 PLC ± 2 PLC ± 3 PLC ± 4 PLC ± ANGLES ± FINISH		DWN L. ZHANG 26 JUL 2012 CHK L. ZHANG 26 JUL 2012 APVD S. XI 26 JUL 2012	NAME Ocean Side Feed Applicator SIZE A1 CAGE CODE 00779 DRAWING NO C=2151353 RESTRICTED TO -
MATERIAL		FINISH		WEIGHT - SCALE 1:2 SHEET 3 OF 4 REV L	Customer Accessible Production Drawing

LOC		DIST		REVISIONS			
A	66	P	LTM	DESCRIPTION	DATE	OWN	APVD
		-	-	SEE SHEET 1	-	-	-

FEED TYPE MECHANICAL

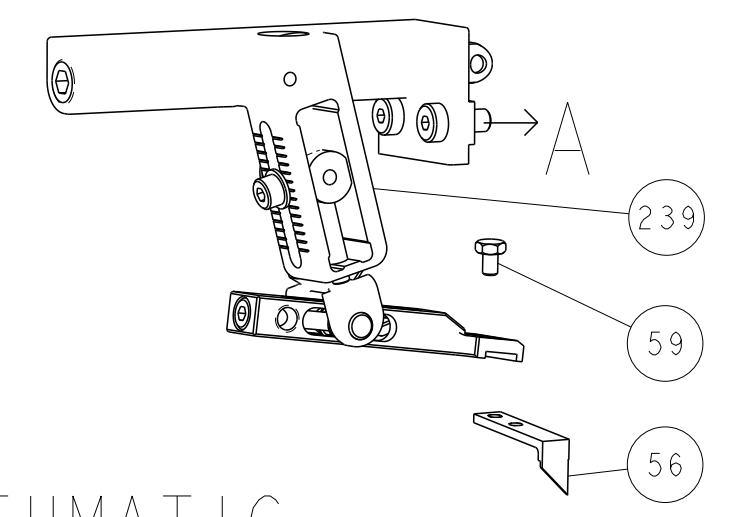

PNEUMATIC

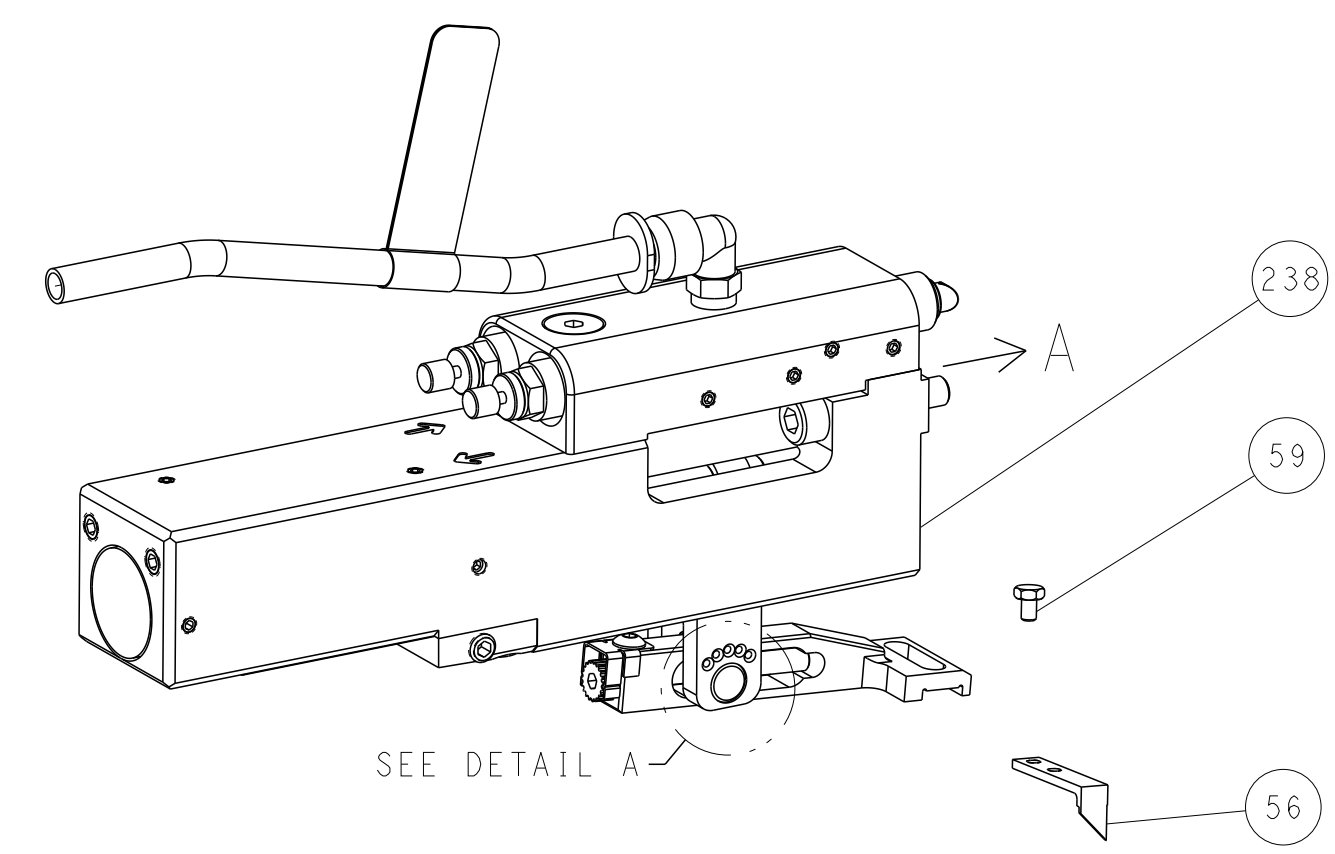

FEED SPRING SETTING POSITION (SHOWN FROM REAR SIDE)

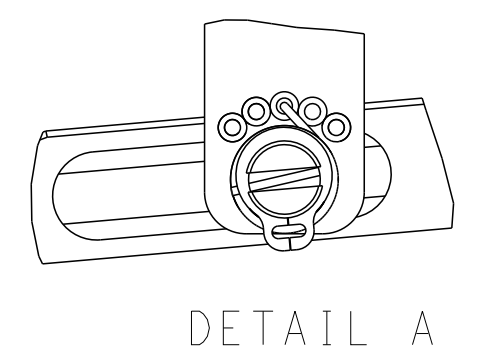

CAM POSITIONS

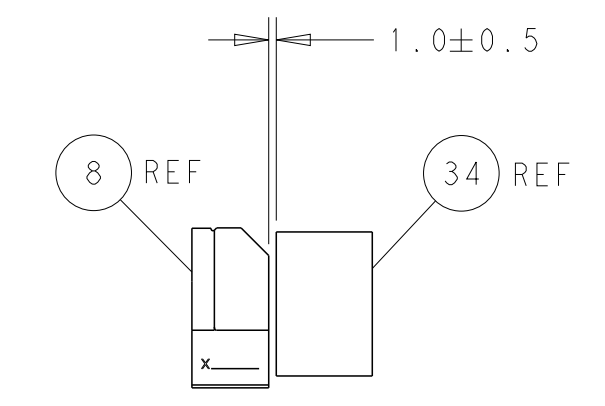
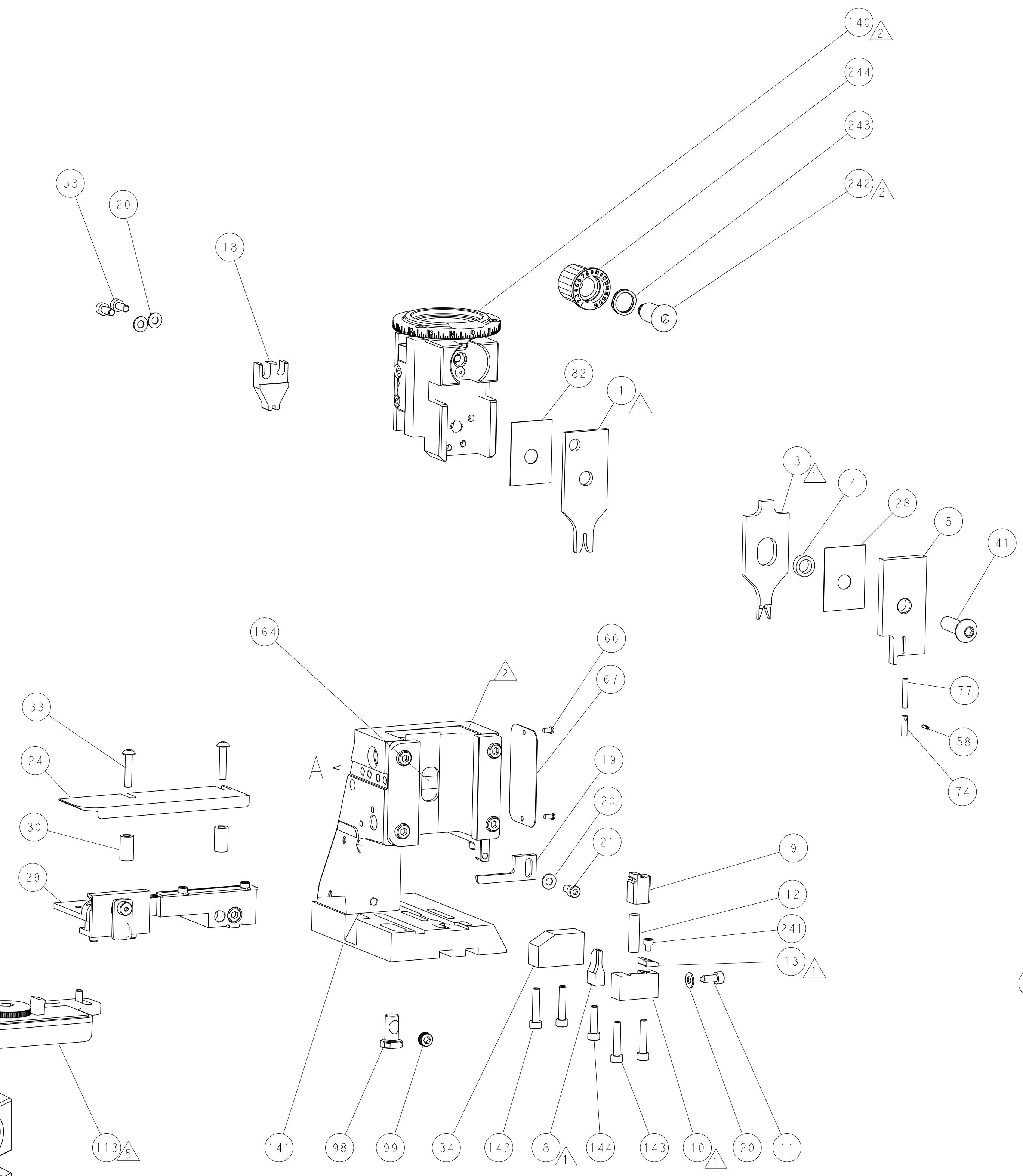
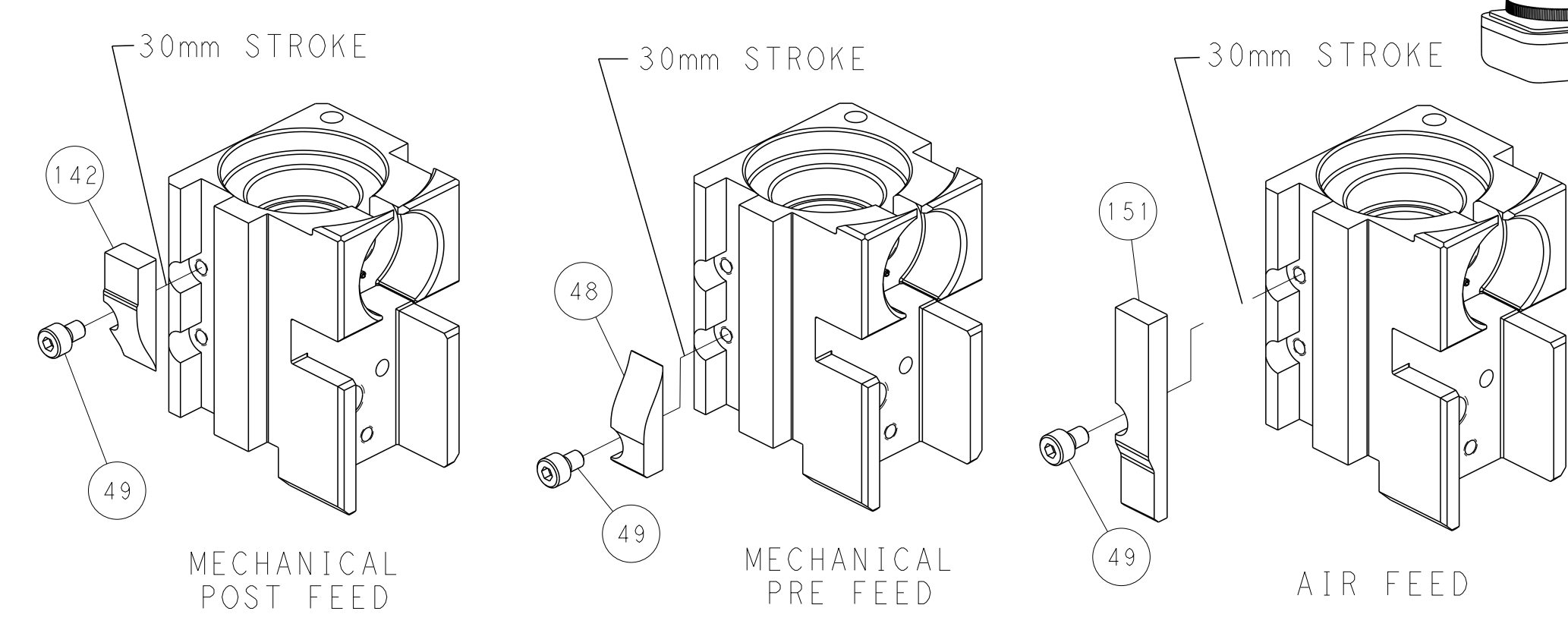

TERMINAL SUPPORT LOCATION

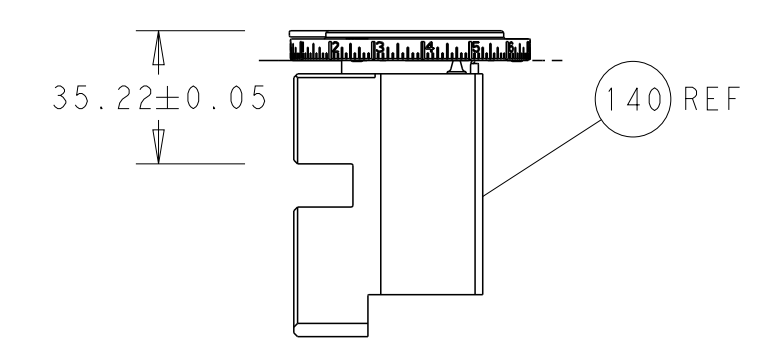

RAM SET-UP

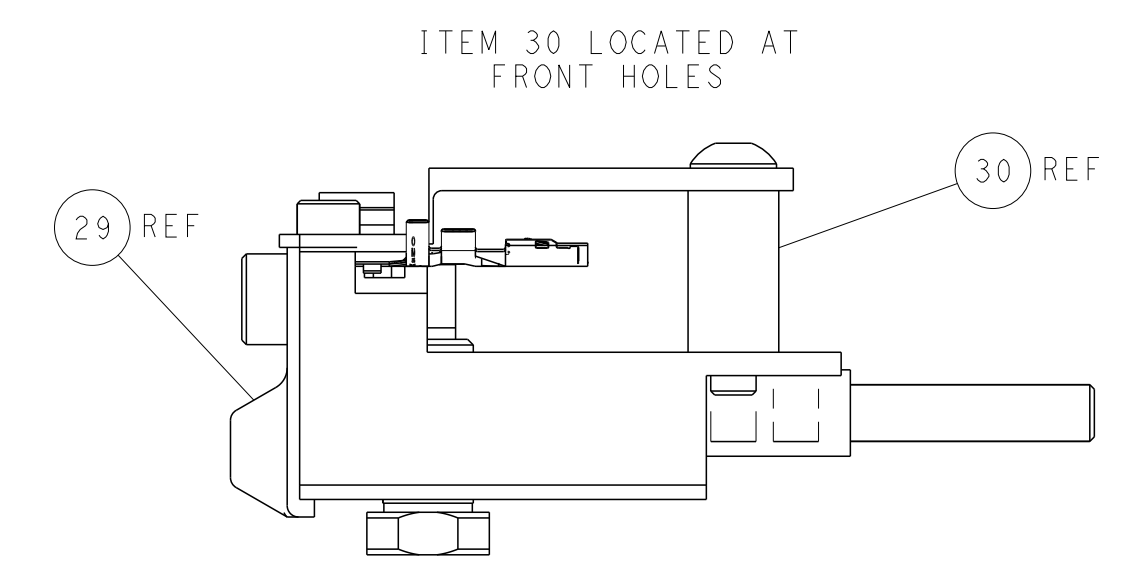

FEED TRACK POSITION GUIDE BY INSULATION BARREL

PACIFIC VERSION
 Shown on sheets 3 of 4 & 4 of 4
 (Atlantic version shown on sheets 1 of 4 & 2 of 4)

DIMENSIONS:		TOLERANCES UNLESS OTHERWISE SPECIFIED:		DWG L. ZHANG 26 JUL 2012		CHK L. ZHANG 26 JUL 2012		NAME	
mm	0 PLC ±	1 PLC ±	2 PLC ±	3 PLC ±	4 PLC ±	APVD S. XI 26 JUL 2012	PRODUCT SPEC	Ocean Side Feed Applicator	
MATERIAL		FINISH		WEIGHT		SCALE		RESTRICTED TO	
						1:2		SHEET 4 OF 4 REV L	