

▲ SPST MOMENTARY CIRCUIT

NOTES:

1. ALL DIMENSIONS IN MM [INCH]
2. GENERAL TOLERANCE: X.X=±0.4
X.XX=±0.25
3. CONTACT RATING: 50mA @ 12VDC
4. CONTACT RESISTANCE: 100mΩ MAX.
5. INSULATION RESISTANCE: 100MΩ MIN @ 500VDC.
- ▲ 6. OPERATING FORCE: 260 ± 50gf
7. TRAVEL: 0.15 mm
8. OPERATING TEMPERATURE: -25°C TO + 70°C
9. OPERATING LIFE: 200,000 CYCLES
- ▲ 10. CONTACTS: SILVER
11. ▲ DENOTES CRITICAL PARAMETERS
12. PARTS TO BE PACKAGED IN TAPE AND REEL

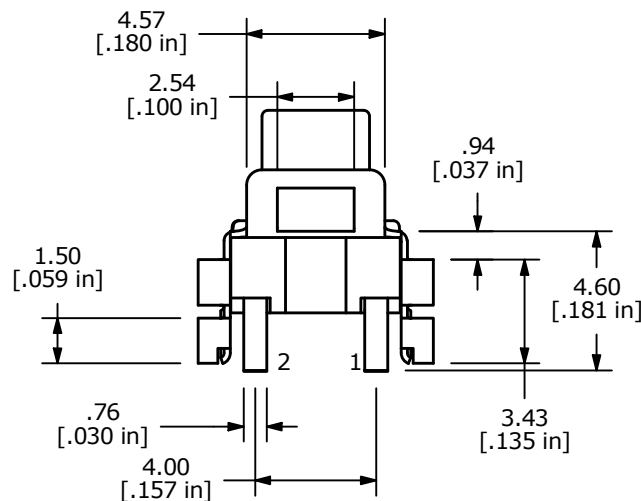
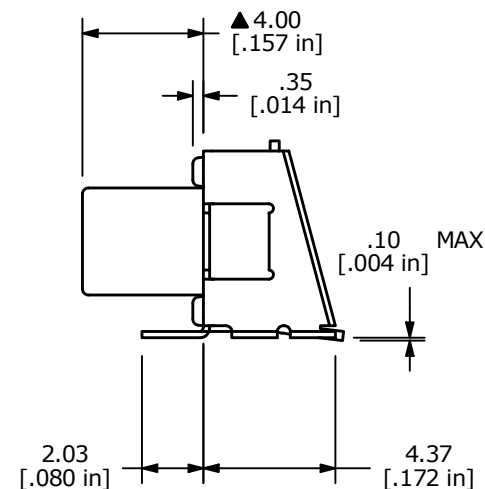
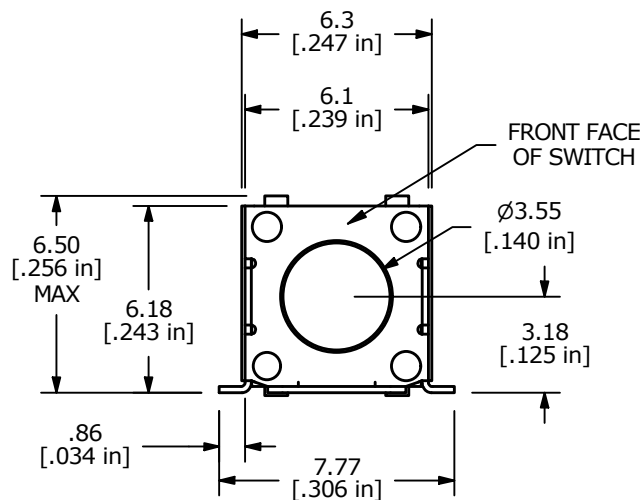
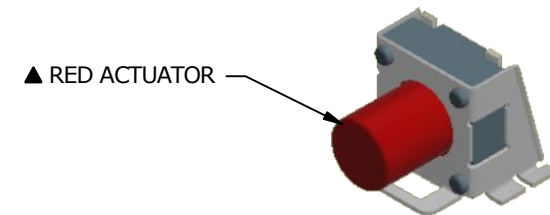

REV	ECO NO	DESCRIPTION	DATE	BY
B	ECO-101239	ADDED 0.38 DIM TO PCB LAYOUT	09/15/22	JS



OBJECT ID
000017028

TITLE TL3360CF260Q				
SCALE 4:1	DATE 6/15/2015	DR RC	DWG N330006	REV B