



## SMD1812R150SF24V Surface Mount PTC Devices

### APPROVAL SHEET

MODEL NO.: SMD1812R150SF24V

CUSTOMER:

CUSTOMER'S APPROVAL:

AUTHORIZED SIGNATURE/STAMP

DATE

MANUFACTURER:

常州鼎先电子有限公司

Tel: 13775299578 0519-88171671

Fax: 0519-88171679

Submitted by:

Approved by:

Date:

## SMD1812R150SF24V Surface Mount PTC Devices

### Performance Specification

Model	Marking	V <sub>max</sub> (V dc)	I <sub>max</sub> (A)	I <sub>hold</sub> @25°C (A)	I <sub>trip</sub> @25°C (A)	P <sub>d</sub> Typ. (W)	Maximum Time To Trip		Resistance	
							Current (A)	Time (Sec)	R <sub>i min</sub> (Ω)	R <sub>1max</sub> (Ω)
SMD1812R150SF24V	R150	24.0	35	1.50	3.00	0.8	8.0	0.50	0.040	0.160

V<sub>max</sub> = Maximum operating voltage device can withstand without damage at rated current (I<sub>max</sub>).

I<sub>max</sub> = Maximum fault current device can withstand without damage at rated voltage (V<sub>max</sub>).

I<sub>hold</sub> = Hold Current. Maximum current device will not trip in 25°C still air.

I<sub>trip</sub> = Trip Current. Minimum current at which the device will always trip in 25°C still air.

P<sub>d</sub> = Power dissipation when device is in the tripped state in 25°C still air environment at rated voltage.

R<sub>i min</sub>/max = Minimum/Maximum device resistance prior to tripping at 25°C.

R<sub>1max</sub> = Maximum device resistance is measured one hour post reflow.

CAUTION : Operation beyond the specified ratings may result in damage and possible arcing and flame.

### Environmental Specifications

Test	Conditions	Resistance change
Passive aging	+85°C, 1000 hrs.	I HOLD/I TRIP PASS
Humidity aging	+85°C, 85% R.H. , 168 hours	I HOLD/I TRIP PASS
Thermal shock	+85°C to -40°C, 20 times	I HOLD/I TRIP PASS
Resistance to solvent	MIL-STD-202,Method 215	电阻不變化
Vibration	MIL-STD-202,Method 201	电阻不變化
Ambient operating conditions : - 40 °C to +85 °C		
Maximum surface temperature of the device in the tripped state is 125 °C		

### Agency Approval and Environmental Compliance

Agency	File Number	Regulation	Standard
UL	pending		2002/95/EC
TUV	pending		EN14582

### Thermal Derating Chart

Recommended Hold Current(A) at Ambient Temperature(°C)

Model	Ambient Operation Temperature								
	-40°C	-20°C	0°C	25°C	40°C	50°C	60°C	70°C	85°C
SMD1812R150SF	2.10	1.96	1.77	1.50	1.23	1.09	0.95	0.82	0.61

# SMD1812R150SF24V Surface Mount PTC Devices

## Thermal Derating Curve

## Average Time-Current Curve

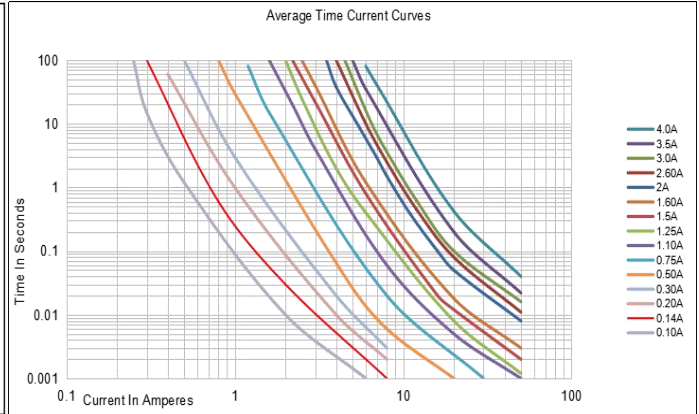
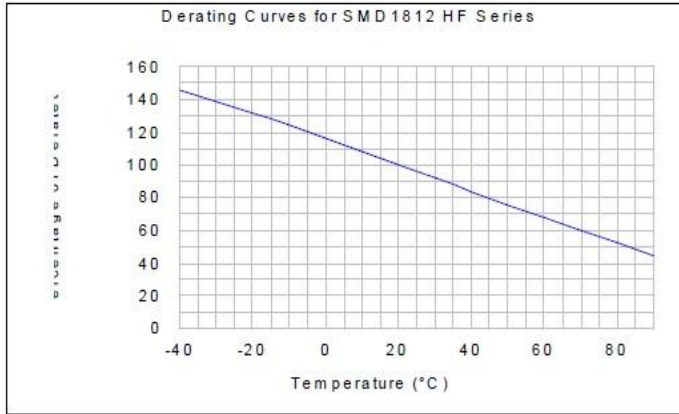

## Soldering Parameters

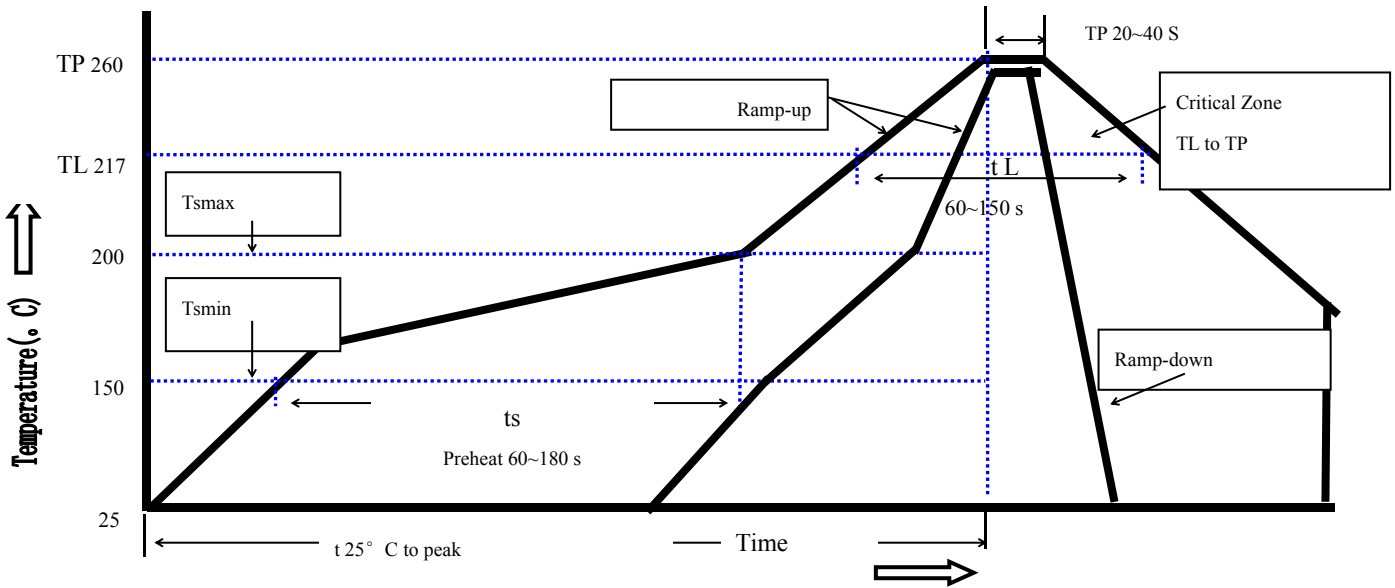

Profile Feature	Pb-Free Assembly
Average Ramp-Up Rate(Ts max to T p)	3°C/second max.
Preheat	
-Temperature Min(Ts min)	150°C
-Temperature Max(Ts max)	200°C
-Time(Ts min to Ts max)	60~180 seconds
Time maintained above:	
-Temperature(TL)	217°C
-Time(tL)	60~150 seconds
Peak Temperature(Tp)	260°C
Ramp-Down Rate	6°C/second max.
Time 25°C to Peak Temperature	8 minutes max
Storage Condition	0°C~30°C,30%-60%RH

Recommended reflow methods: IR, vapor phase oven, hot air oven, N2 environment for lead-free

## SMD1812R150SF24V Surface Mount PTC Devices

Recommended maximum paste thickness is 0.25mm

Devices can be cleaned using standard industry methods and solvents.

Note 1: All temperature refer to topside of the package, measured on the package body surface.

Note 2: If reflow temperatures exceed the recommended profile, devices may not meet the performance requirements.

### Physical Dimensions(mm.)

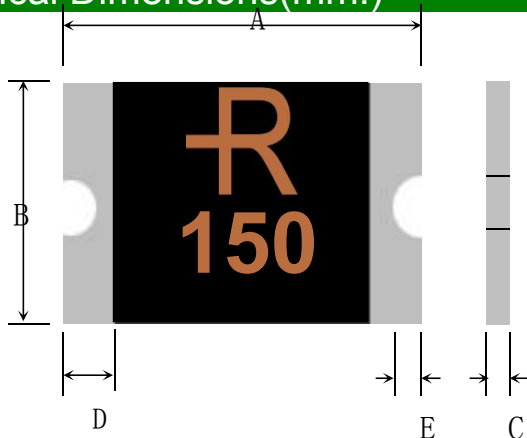

Model	A		B		C		D	E
	Min.	Max.	Min.	Max.	Min.	Max.	Min.	Min.
SMD1812R150SF24V	4.37	4.73	3.07	3.41	0.50	1.10	0.30	0.25

#### Termination Pad Characteristics

Terminal pad materials: Tin-plated Nickel-Copper

Terminal pad solder ability: Meets EIA specification RS186-9E and ANSI/J-STD-002 Category 3.

### Recommended Pad Layout (mm.)

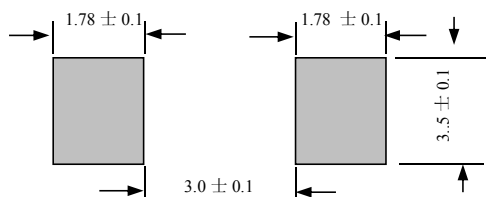

注：在此印锡面积条件下，推荐钢网厚度为 $\geq 0.12\text{MM}$ (钢网厚度不够要增大刷锡面积)

### Packaging Quantity

Part Number	Quantity
SMD1812R150SF24V	1,500 pcs/reel

Tape & reel packaging per EIA481-1

# SMD1812R150SF24V Surface Mount PTC Devices

## Tape And Reel Specifications (mm)

Governing Specifications		EIA 481-1
W		12 ± 0.3
P0		4.0 ± 0.10
P1		8.0 ± 0.10
P2		2.0 ± 0.05
A0		3.5 ± 0.10
B0		5.1 ± 0.10
B1max.		5.9
D0		1.50 + 0.1, -0
F		5.5 ± 0.05
E1		1.75 ± 0.10
E2min.		10.25
T		0.6
T1max.		0.1
K0		0.9 ± 0.1
Leader min.		390
Trailer min.		160
Reel Dimensions		
A max.		178
N min.		60
W1		12.4 ± 0.5
W2		18.4

EIA Tape Component Dimensions

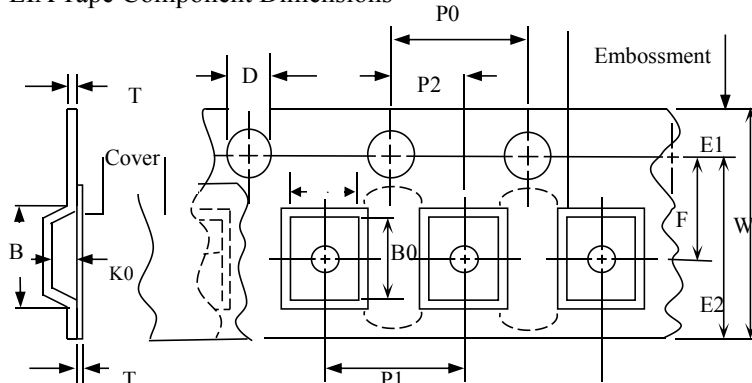

EIA Reel Dimensions

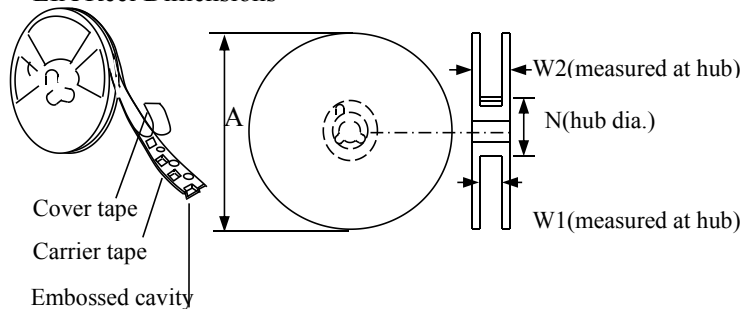

### Storage And Handling

- Storage conditions: 0°C~30°C, 30%~60% R.H.
- Devices may not meet specified performance if storage conditions are exceeded.

## Part Number System

**SMD 1812 R 150 S F 24V**

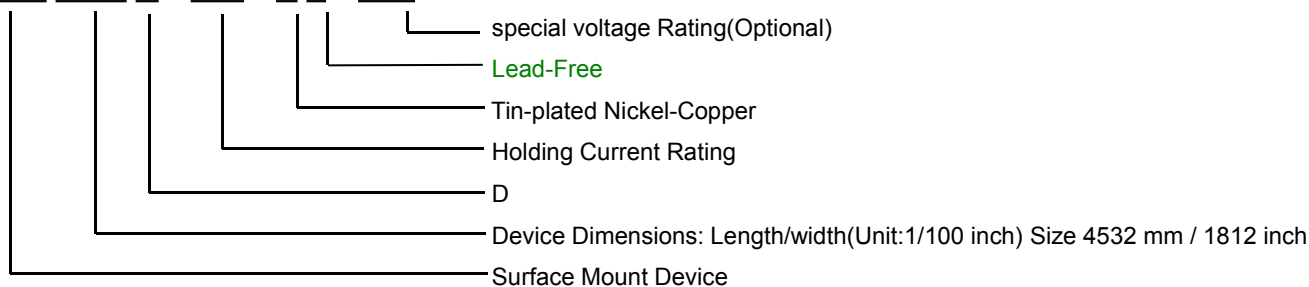

### 注意事项

PPTC 使用注意事项:

- PPTC 为热敏元件，对环境温度比较敏感，建议在 PPTC 周围不要设计热源元件，尽量减少外部热源的影响。
  - 请在规格书规定的参数下 (<10%) 使用，超出电压电流规格值，会导致 PPTC 出现电弧，阻值升高，甚至烧片。
  - 规格书的电气特性，均是基于在指定测试板经过一次回流焊之后的测试；如果客户有二次回流焊或者注塑点胶等其他热工序，会对上述参数有一定程度的衰减，需要验证其适用性。
  - PPTC 贴片产品是为 SMT 工艺设计的封装形式，焊接工艺为回流焊；要求客户遵守我们推荐的焊盘布局和回流焊配置文件。不正确的电路板布局或回流配置可能会对 PPTC 的可焊性性能产生负面影响。焊接工艺可参考推荐的回流焊曲线。如果回流焊温度超过推荐的值，PPTC 将有可能受到损伤。使用手工焊及波峰焊接 PPTC 可能会导致产品焊后电阻超出规格。
  - 某些注塑料、单组份、双组份固化胶粘剂、硅胶、侵蚀性溶剂污染 PPTC 材料破坏芯片，需要对注塑料胶料等材料牌号以及应用参数（如温度、时间等）进行验证，以确保产品及工艺的匹配性，确认不会影响 PPTC 性能之后方可使用。
- PPTC 在充电线端应用中，建议使用 PP 类材料做内膜，禁止使用 TPE 类与 PVC 类等材料做内膜。
- PPTC 贴装或使用过程中，不建议使用洗板水或其他清洗剂进行清洗。如必须使用，需要验证各类清洗剂、洗板水以及溶剂的适用性，确认不会影响 PPTC 性能之后方可使用。已知对 PPTC 有影响的化学药品包括但不限于醚类、苯类、酮类以及脂类等较强溶解性、破坏性的有机化合物，清洗后将产品放置于敞开的环境中至少 24 小时，将残留的溶剂进行充分的挥发。
  - 装配过程中，避免用暴力砸、挤、压、拉、扭、刺等方式作用 PPTC 本体，以免引起 PPTC 性能衰减。
  - PPTC 元件是为电路中偶尔出现的过流而设计的，不建议用在连续且持续过流的电路中。
  - SMD PPTC 湿敏等级为 2 级，为密封包装。客户如在库存中发现有包装破损的，立即将产品隔离处理；使用时如有余料，需恢复之前包装状态，做密封保存，否则会影响产品性能导致焊后电阻越规格。
  - 产品废弃时，可按照一般电子废弃物处理，具体材料组成可参见 MSDS