

DATE	DESCRIPTION	REV.
10.08.13	CHANGE AS PER ECN 13-091 CONTACT MAT'L PHOSPHOR BRONZE	A
1.14.20	CHANGE AS PER ECN 20-001 (B1) WAS 3.386 [86.00] ADJUST MOUNTING LAYOUT TO MAX. TOLERANCE.	B

- NOTE:
1. BASE:
MAT'L: HEAT RESISTANCE NYLON
STANYL 46 OR EQUIVALENT
 2. CONTACT:
MAT'L: .012 [0.30] THK STAINLESS STEEL
FINISH: GOLD FLASH, OVER NICKEL PLATE
 3. HOLDER DESIGNED FOR BATTERIES 67mm LONG
WITH BUILD IN CIRCUIT PROTECTION

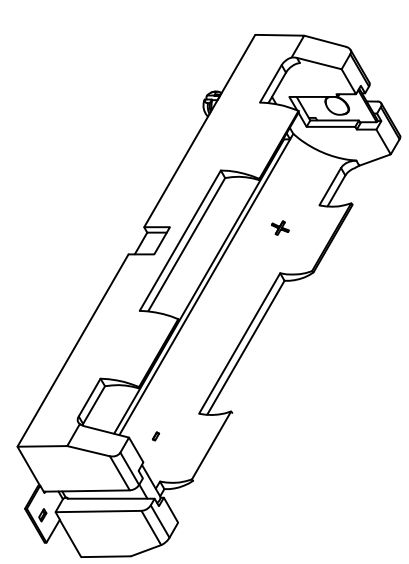

THIS DOCUMENT IS THE PROPERTY OF KEYSTONE ELECTRONICS CORP. AND SHALL NOT BE REPRODUCED, DISTRIBUTED OR USED AS A BASIS FOR MANUFACTURE WITHOUT PRIOR WRITTEN PERMISSION FROM KEYSTONE ELECTRONICS CORP.

KEYSTONE ELECTRONICS CORP.			
www.keystec.com • ASTORIA, N.Y. 11105-2017 • Tel (718) 956-8900			
PART NAME PC POLARIZED BATTERY HOLDER			
MATERIAL AS NOTED			
FINISH AS NOTED	DRN BY NT	DATE 7.12.13	
TOLERANCES DECIMAL ± .010 [± 0.25] ANGULAR ± 1°	CODE C	DWG NO. 1042P	SCALE 1.25X