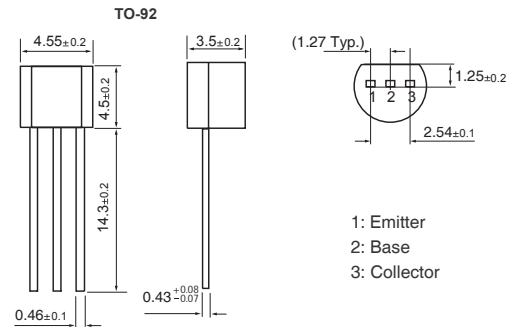

FEATURES

- Complimentary to S8550
- Collector Current: $I_C = 0.5\text{ A}$

ABSOLUTE MAXIMUM RATINGS at $T_a = 25^\circ\text{C}$

Parameter	Symbol	Ratings	Unit
Collector to Base Voltage	V_{CBO}	40	V
Collector to Emitter Voltage	V_{CEO}	25	V
Emitter to Base Voltage	V_{EBO}	5	V
Collector Current	I_C	500	mA
Total Power Dissipation	P_D	625	mW
Junction, Storage Temperature	T_J, T_{STG}	+150, -55 ~ +150	$^\circ\text{C}$

ELECTRICAL CHARACTERISTICS ($T_{AMB} = 25^\circ\text{C}$ unless otherwise specified)

Parameter	Symbol	Min.	Typ.	Max.	Unit	Test Conditions
Collector-base Breakdown Voltage	$V_{(BR)CBO}$	40	-	-	V	$I_C = 100\ \mu\text{A}, I_E = 0$
Collector-emitter Breakdown Voltage	$V_{(BR)CEO}$	25	-	-	V	$I_C = 0.1\ \text{mA}, I_B = 0$
Emitter-base Breakdown Voltage	$V_{(BR)EBO}$	5	-	-	V	$I_E = 100\ \mu\text{A}, I_C = 0$
Collector Cut-off Current	I_{CBO}	-	-	0.1	μA	$V_{CB} = 40\ \text{V}, I_E = 0$
Collector Cut-off Current	I_{CEO}	-	-	0.1	μA	$V_{CE} = 20\ \text{V}, I_B = 0$
Emitter Cut-off Current	I_{EBO}	-	-	0.1	μA	$V_{EB} = 5\ \text{V}, I_C = 0$
DC Current Gain	$h_{FE(1)}$	85	-	400		$V_{CE} = 1\ \text{V}, I_C = 50\ \text{mA}$
	$h_{FE(2)}$	50	-	-		$V_{CE} = 1\ \text{V}, I_C = 500\ \text{mA}$
Collector-emitter Saturation Voltage	$V_{CE(sat)}$	-	-	0.6	V	$I_C = 500\ \text{mA}, I_B = 50\ \text{mA}$
Base-emitter Saturation Voltage	$V_{BE(sat)}$	-	-	1.2	V	$I_C = 500\ \text{mA}, I_B = 50\ \text{mA}$
Transition Frequency	f_T	150	-	-	MHz	$V_{CE} = 6\ \text{V}, I_C = 20\ \text{mA}, f = 30\ \text{MHz}$

CLASSIFICATION OF h_{FE}

Rank	B	C	D
Range	85 - 160	120 - 200	160 - 300

CHARACTERISTIC CURVES
S8050

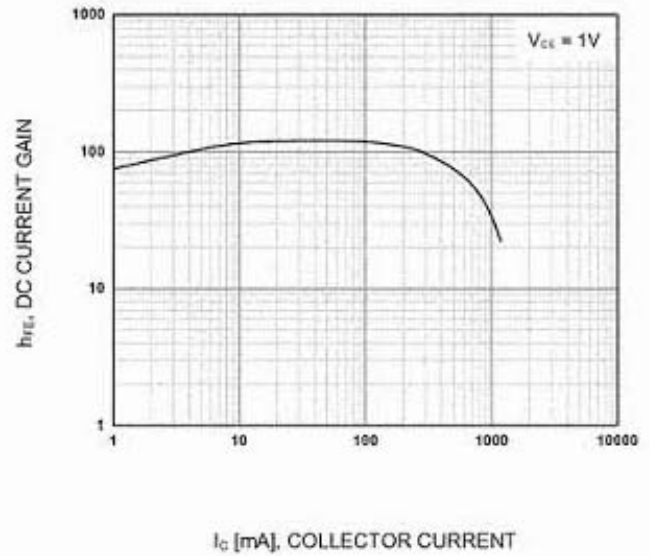
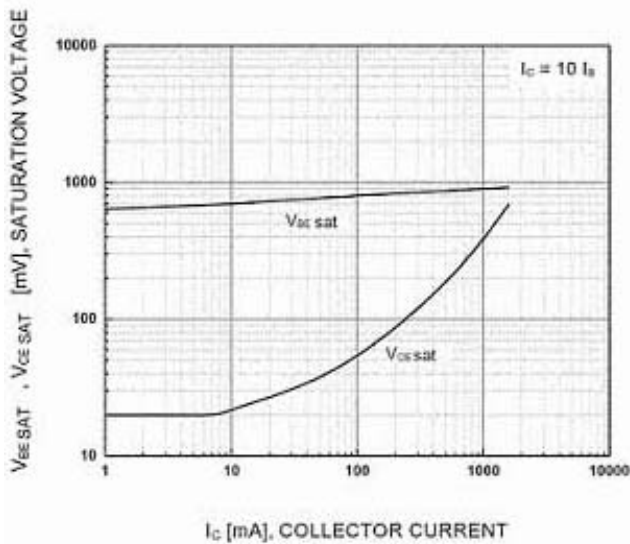
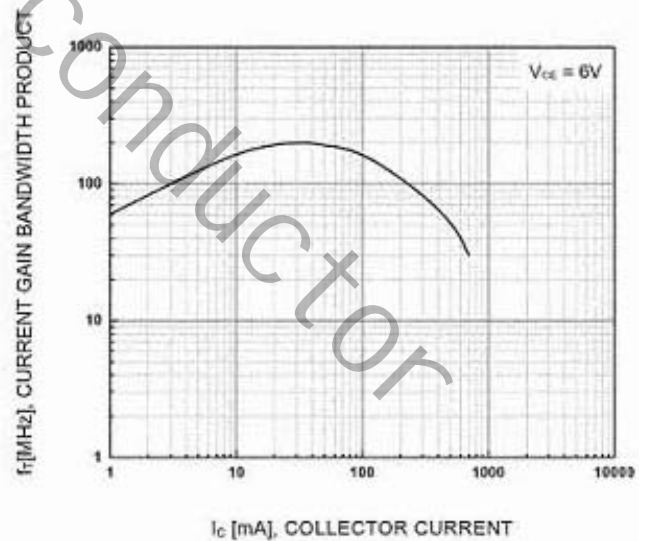
Static Characteristic

DC current Gain

**Base-Emitter Saturation Voltage
Collector-Emitter Saturation Voltage**

Current Gain Bandwidth Product