

MOUNTING DETAIL

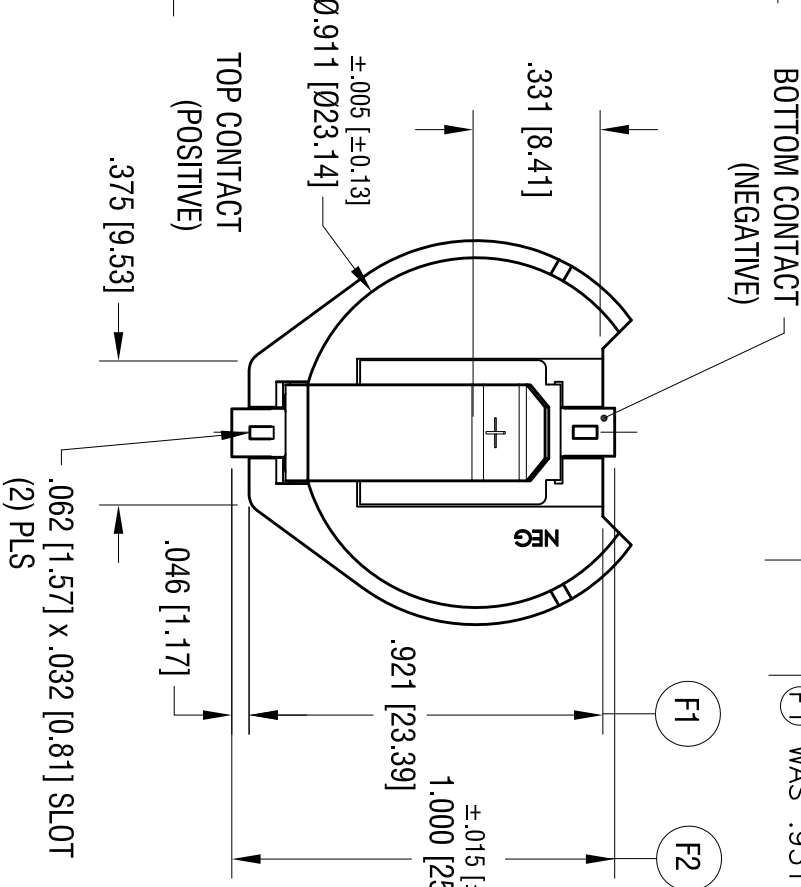

DATE	DESCRIPTION	REV.
9.17.04	CHANGE AS PER ECN 04-108	C
7.05.11	CHANGE AS PER ECN 11-090 SPLIT C/M TO 'C' AND 'M'	D
8.15.11	CHANGE AS PER ECN 11-108	E
1.10.22	CHANGE AS PER ECN 22-002 (F1) WAS .931, (F2) WAS 1.015	F

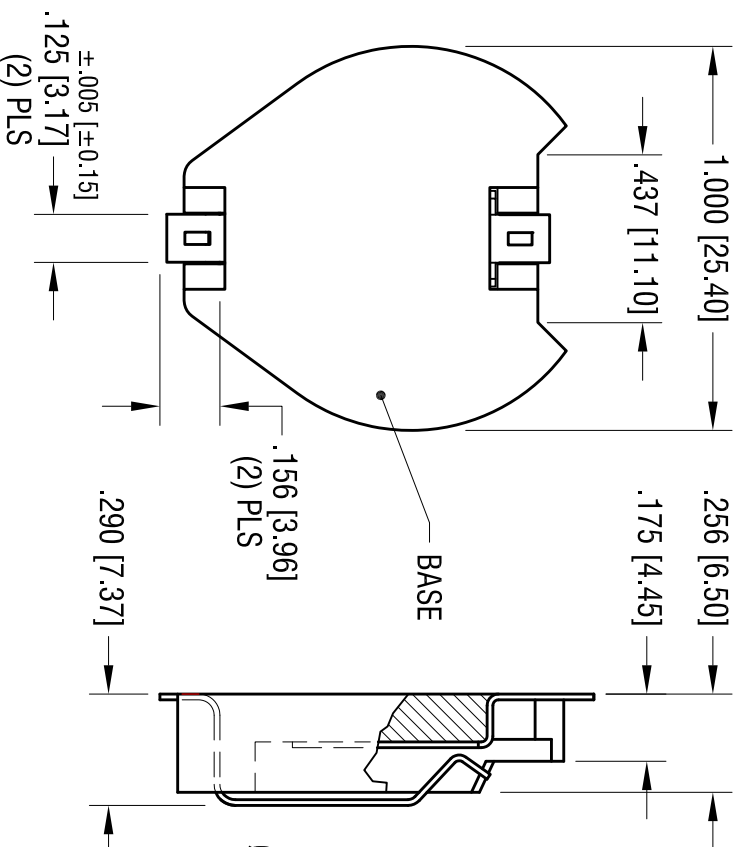
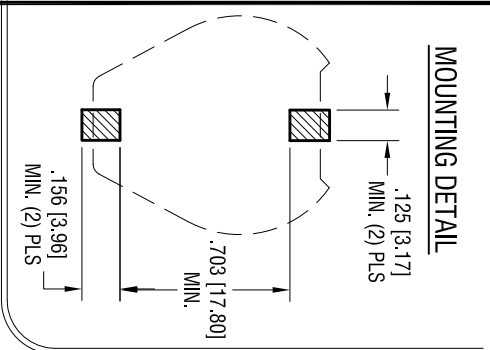
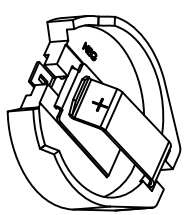

ACTUAL SIZE

- NOTES:**
1. BASE:
MATEL - HIGH TEMPERATURE NYLON (UL 94V-0)
COLOR BLACK
 2. CONTACTS (TOP AND BOTTOM):
MATEL - .015 [0.38] THK SPRING STEEL
FINISH: TIN NICKEL PLATE

KEYSTONE ELECTRONICS CORP.
www.keystec.com • NEW HYDE PARK, NY 11040 • Tel (516) 328-7500

PART NAME: 23mm BATTERY HOLDER, SMT

MATERIAL: AS NOTED

FINISH: AS NOTED

TOLERANCES	INCH	[MM]	CODE	DWG NO.
DECIMAL	± .010	[± 0.25]	C	1071
ANGULAR	± 1°			

DRN BY: BOONE DATE: 7.16.98
APP'D: RH SCALE: 2X

THIS DOCUMENT IS THE PROPERTY OF KEYSTONE ELECTRONICS CORP. AND SHALL NOT BE REPRODUCED, DISTRIBUTED OR USED AS A BASIS FOR MANUFACTURE WITHOUT PRIOR WRITTEN PERMISSION FROM KEYSTONE ELECTRONICS CORP.